



Caseta De Jardín · Arrumação Exterior · Abri De Jardin · Gerätehaus · Στιπτάκι
Záhradné Domčeky · Vrtne Kućice · Zahradní Domek · Vrtne Hišice
Trädgårdsbod · Bahçe Kulübesi · Kasolle kopshti · Садовый домик
Domek ogrodowy · Kerti házikó



USER'S MANUAL · MANUAL DE INSTRUCCIONES · MANUAL DE INSTRUÇÕES
MANUEL D'INSTRUCTIONS · GEBRAUCHSANWEISUNG · ΕΓΧΕΙΡΙΔΙΟ ΧΡΗΣΤΗ
MANUALE DI ISTRUZIONI · NÁVOD NA POUŽITIE · PRIRUČNIK · NÁVOD K POUŽITÍ
NAVODILA ZA UPORABO · INSTRUKTIONSHANDBOK · KULLANIM KILAVUZU
MANUAL UDHËZIMESH · РУКОВОДСТВО ПО ЭКСПЛУАТАЦИИ
INSTRUKCJA OBSŁUGI · HASZNÁLATI ÚTMUTATÓ





INDEX

Índice - Inhaltsverzeichnis - Indice - Kazalo - Innehåll - İçindekiler
Përmbajtje - Содержание - Spis treści - Tartalom

EN		User's manual	04
ES		Manual de instrucciones	05
PT		Manual de instruções	06
FR		Manuel d'instructions	07
DE		Gebrauchsanweisung	08
EL		Εγχειρίδιο χρήστη	09
IT		Manuale di istruzioni	10
SK		Návod na použitie	11
HR		Priručnik	12
CS		Návod k použití	13
SL		Navodila za uporabo	14
SV		Bruksanvisning	15
TR		Kullanım kılavuzu	16
SQ		Manual udhëzimesh	17
RU		Содержание	18
PL		Spis treści	19
HU		Tartalomjegyzék	20

Assembly - Montaje - Montagem - Montage Συναρμολόγηση - Montaggio - Montáž - Montaža Montering - Montaj - Montimi - Сборка - Montaž Összeszerelés	21
--	----

USER'S MANUAL

Before we begin...

We want to thank you for choosing one of our products. The assembly process may require a little patience and time, but don't worry, we are here to encourage you! 😊

Once you are finished think of the satisfaction and pride you will feel when you see your finished work and know that you have done it yourself. Also, by assembling it you are making a contribution to the environment. How? As it is not delivered fully assembled, less packaging is used, which means less waste and less waste. In this way each product takes up less space and therefore you make the most of the means of transport, thus reducing CO₂ emissions.

Therefore, with this purchase you are making a conscious choice to protect our planet.

So, go ahead and get to work!



Two people are required to assemble the product



The average assembly time can be between 2 hours for the smaller models and 10-12 hours for the larger ones

🗨️ RECOMMENDATIONS PRIOR TO ASSEMBLY

The product is not designed to be installed directly on the lawn. We recommend assembly on a level and firm wooden base, a flat concrete floor or cemented bricks or blocks.

If a concrete pad is made it is important that it is sloped towards the edges to prevent water ingress.

It is very important to fix the product to the floor. It does not include screws or other parts necessary for anchoring.

🔧 MAINTENANCE

The roof must be kept free of debris, as the weight on top can damage your product.

Do not store chemical, combustible and/or corrosive products inside.

🛡️ WARRANTY

This product is manufactured with the best materials and under strict quality controls and standards. If you detect any problem with the product you have purchased, please contact our customer service department at the telephone number and email address given on the back cover of this instruction manual.

The warranty is valid from the date of purchase shown on the receipt or invoice, which must be presented to make use of the warranty.

The warranty period for this product varies depending on the legal regulations applicable in the country of purchase. Please refer to the regulations in force in the country of purchase for more information.

✖️ EXCLUDED FROM THE WARRANTY

There are certain causes that are excluded from the warranty such as:

- ⌚ If there is a transport non-conformity, the transport agency must be notified within 24 hours of delivery.
- ⌚ Breakage or damage caused by inclement weather.
- ⌚ Incorrect assembly, incorrect use and consequences derived from this.

In addition, you can consult the complete list of these three by scanning the QR on the box.

TOOLS REQUIRED FOR ASSEMBLY

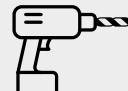

MANUAL DE INSTRUCCIONES

Antes de comenzar...

Queremos agradecerte que hayas elegido uno de nuestros productos. El proceso de montaje puede requerir un poco de paciencia y tiempo, pero no te preocupes ¡estamos aquí para animarte! 😊

Una vez que termines piensa en la satisfacción y orgullo que sentirás al ver tu trabajo terminado y saber que lo has hecho tú mismo. Además, al montarlo estás haciendo una contribución al medio ambiente. ¿Cómo? Al no ser entregado completamente armado, se utiliza menos embalaje, lo que significa menos residuos y menos desperdicio. De esta manera cada producto ocupa menos espacio y por lo tanto se aprovecha al máximo los medios de transporte reduciendo de esta manera las emisiones de CO₂.

Por lo tanto, con esta compra estás haciendo una elección consciente para proteger nuestro planeta.

Ahora sí... ¡Adelante y manos a la obra!



Son necesarias dos personas para el montaje del producto



El tiempo medio de montaje puede estar entre las 2h de los modelos más pequeños a las 10-12h de los más grandes

RECOMENDACIONES PREVIAS AL MONTAJE

El producto no está diseñado para ser instalada directamente sobre el césped. Recomendamos el montaje sobre una base nivelada y firme de madera, un suelo llano de cemento o ladrillos o bloques cementados.

Si se hace una plataforma de cemento es importante que se incline hacia los bordes para evitar la entrada de agua. Es muy importante fijar el producto al suelo. No incluye tornillos ni otras piezas necesarias para su anclaje.

MANTENIMIENTO

El techo debe mantenerse limpio de residuos, ya que el peso en la parte superior puede deteriorar tu producto. No guarde productos químicos, combustibles y/o corrosivos en su interior.

GARANTÍA

Este producto está fabricado con los mejores materiales y bajo estrictos controles y estándares de calidad. En caso de detectar algún inconveniente en el producto adquirido, rogamos te pongas en contacto con el servicio de atención al cliente en el teléfono y email que aparecen descritos en la contraportada de este manual de instrucciones.

La garantía es válida a partir de compra que aparece en el ticket o factura, el cual deberá presentarse para hacer uso de la garantía.

El periodo de garantía de este producto varía en función de la normativa legal aplicable en el país de compra. Consulte la normativa vigente del país para más información.

QUEDAN EXCLUIDAS DE LA GARANTÍA

Hay ciertas causas que quedan excluidas de la garantía como:

- ⊙ Si existe una no conformidad del transporte, hay que comunicárselo a la agencia de transportes antes de que transcurran 24h desde la entrega.
- ⊙ Las roturas o daños generados por inclemencias meteorológicas.
- ⊙ El mal montaje, uso incorrecto y consecuencias derivadas de ello.

Además, de estas tres puedes consultar la lista completa en escaneando el QR de la caja.

**HERRAMIENTAS
NECESARIAS PARA
SU MONTAJE**

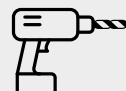

MANUAL DE INSTRUÇÕES

Antes de começarmos...

Queremos agradecer-lhe por ter escolhido um dos nossos produtos. O processo de montagem pode exigir um pouco de paciência e tempo, mas não se preocupe, estamos aqui para o encorajar! 😊

Quando terminar, pense na satisfação e no orgulho que sentirá quando vir o seu trabalho acabado e souber que foi feito por si. Além disso, ao montá-lo, está a contribuir para o ambiente. Como? Como não é entregue totalmente montado, é utilizada menos embalagem, o que significa menos resíduos e menos desperdício. Desta forma, cada produto ocupa menos espaço e, portanto, aproveita-se ao máximo os meios de transporte, reduzindo assim as emissões de CO₂.

Portanto, com esta compra, está a fazer uma escolha consciente para proteger o nosso planeta.

Por isso, ponha mãos à obra!



São necessárias duas pessoas para montar o produto



O tempo médio de montagem pode ser de 2 horas para os modelos mais pequenos e de 10 a 12 horas para os modelos maiores

RECOMENDAÇÕES ANTES DA MONTAGEM

O produto não foi concebido para ser instalado diretamente no relvado. Aconselhamos a montagem sobre uma base de madeira nivelada e firme, sobre um chão de betão plano ou sobre tijolos ou blocos cimentados.

Se for feita uma base de betão, é importante que esta seja inclinada para os bordos para evitar a entrada de água.

É muito importante fixar o produto ao chão. Não inclui parafusos ou outras peças necessárias para a fixação.

MANUTENÇÃO

O teto deve ser mantido livre de detritos, uma vez que o peso no topo pode danificar o seu produto.

Não guardar produtos químicos, combustíveis e/ou corrosivos no interior.

GARANTIA

Este produto é fabricado com os melhores materiais e sob rigorosos controlos e normas de qualidade. Se detetar algum problema com o produto que adquiriu, contacte o nosso serviço de apoio ao cliente através do número de telefone e do endereço de correio eletrónico indicados na contracapa do presente manual de instruções.

A garantia é válida a partir da data de compra indicada no recibo ou na fatura, que deve ser apresentada para fazer uso da garantia.

O período de garantia deste produto varia consoante os regulamentos legais aplicáveis no país de compra. Para mais informações, consultar a regulamentação em vigor no país de compra.

EXCLUÍDOS DA GARANTIA

Existem determinadas causas que estão excluídas da garantia, tais como:

- ⊗ Em caso de não conformidade de transporte, a entidade transportadora deve ser notificada no prazo de 24 horas após a entrega.
- ⊗ Quebra ou danos causados por intempéries.
- ⊗ Montagem incorrecta, utilização incorrecta e consequências daí resultantes.

Para além disso, pode consultar a lista completa destas três advertências através da leitura do QR na caixa.

**FERRAMENTAS
NECESSÁRIAS
PARA A MONTAGEM**



MANUEL D'INSTRUCTIONS

Avant de commencer...

Nous tenons à vous remercier d'avoir choisi l'un de nos produits. Le processus d'assemblage peut nécessiter un peu de patience et de temps, mais ne vous inquiétez pas, nous sommes là pour vous encourager ! 😊

Une fois que vous aurez terminé, pensez à la satisfaction et à la fierté que vous éprouverez en voyant votre travail terminé et en sachant que vous l'avez fait vous-même. De plus, en l'assemblant, vous contribuez à la protection de l'environnement. Comment ? Comme il n'est pas livré entièrement assemblé, moins d'emballage est utilisé, ce qui signifie moins de déchets et moins de gaspillage. De cette manière, chaque produit prend moins de place et vous exploitez au maximum les moyens de transport, réduisant ainsi les émissions de CO₂.

Avec cet achat, vous faites donc un choix conscient pour protéger notre planète.

Alors, n'hésitez plus et mettez-vous au travail !



Deux personnes sont nécessaires pour assembler le produit



Le temps de montage moyen peut être de 2 heures pour les petits modèles et de 10 à 12 heures pour les plus grands

RECOMMANDATIONS AVANT L'ASSEMBLAGE

Le produit n'est pas conçu pour être installé directement sur la pelouse. Nous recommandons de l'assembler sur une base en bois plane et ferme, sur un sol plat en béton ou sur des briques ou des blocs cimentés.

Si un socle en béton est réalisé, il est important qu'il soit incliné vers les bords afin d'éviter les infiltrations d'eau.

Il est très important de fixer le produit au sol. Les vis et autres éléments nécessaires à l'ancrage ne sont pas inclus.

ENTRETIEN

Le toit doit être maintenu exempt de débris, car le poids qui s'y trouve peut endommager votre produit.

Ne pas stocker de produits chimiques, combustibles et/ou corrosifs à l'intérieur.

GARANTIE

Ce produit est fabriqué avec les meilleurs matériaux et selon des normes et des contrôles de qualité stricts. Si vous constatez un problème quelconque avec le produit que vous avez acheté, veuillez contacter notre service clientèle au numéro de téléphone et à l'adresse électronique indiqués au dos de ce manuel d'instructions.

La garantie est valable à partir de la date d'achat indiquée sur le ticket de caisse ou la facture, qui doivent être présentés pour bénéficier de la garantie.

La période de garantie de ce produit varie en fonction des dispositions légales applicables dans le pays d'achat. Pour plus d'informations, veuillez vous référer à la réglementation en vigueur dans le pays d'achat.

EXCLUS DE LA GARANTIE

Certaines causes sont exclues de la garantie:

- En cas de non-conformité du transport, l'agence de transport doit être informée dans les 24 heures suivant la livraison.
- Casse ou dommages causés par les intempéries.
- Un montage incorrect, une utilisation incorrecte et les conséquences qui en découlent.

En outre, vous pouvez consulter la liste complète de ces trois éléments en scannant le QR sur la boîte.

**OUTILS
NÉCESSAIRES À
L'ASSEMBLAGE**



GEBRAUCHSANWEISUNG

Bevor wir beginnen...

Wir möchten Ihnen danken, dass Sie sich für eines unserer Produkte entschieden haben. Der Zusammenbau kann ein wenig Geduld und Zeit erfordern, aber keine Sorge, wir sind hier, um Sie zu unterstützen! 😊

Wenn Sie fertig sind, denken Sie an die Zufriedenheit und den Stolz, den Sie empfinden werden, wenn Sie Ihr fertiges Werk sehen und wissen, dass Sie es selbst gemacht haben. Außerdem leisten Sie durch den Zusammenbau einen Beitrag zum Umweltschutz: Da das Produkt nicht komplett zusammengebaut geliefert wird, wird weniger Verpackung verwendet, was wiederum weniger Abfall bedeutet. Auf diese Weise nimmt jedes Produkt weniger Platz ein, und Sie nutzen die Transportmittel optimal aus, wodurch der CO₂-Ausstoß verringert wird.

Mit diesem Kauf treffen Sie also eine bewusste Entscheidung für den Schutz unseres Planeten.

Und jetzt... an die Arbeit!



Für den Zusammenbau des Produkts werden zwei Personen benötigt



Die durchschnittliche Montagezeit kann zwischen 2 Stunden für die kleineren Modelle und 10-12 Stunden für die größeren Modelle liegen

🗨 EMPFEHLUNGEN VOR DER MONTAGE

Das Produkt ist nicht für die direkte Montage auf dem Rasen vorgesehen. Wir empfehlen die Montage auf einer ebenen und festen Holzunterlage, einem flachen Betonboden oder zementierten Ziegeln oder Blöcken.

Bei einer Betonunterlage ist es wichtig, dass sie zu den Kanten hin abgeschrägt ist, um das Eindringen von Wasser zu verhindern. Es ist sehr wichtig, das Produkt auf dem Boden zu befestigen. Schrauben oder andere für die Verankerung notwendige Teile sind nicht im Lieferumfang enthalten.

🔧 WARTUNG

Das Dach muss frei von Ablagerungen gehalten werden, da das Gewicht auf dem Dach Ihr Produkt beschädigen kann. Lagern Sie keine chemischen, brennbaren und/oder ätzenden Produkte im Inneren.

🛡 GARANTIE

Dieses Produkt wird mit den besten Materialien und unter strengen Qualitätskontrollen und -standards hergestellt. Sollten Sie ein Problem mit dem von Ihnen erworbenen Produkt feststellen, wenden Sie sich bitte an unseren Kundendienst unter der auf der Rückseite dieser Bedienungsanleitung angegebenen Telefonnummer und E-Mail-Adresse.

Die Garantie gilt ab dem Kaufdatum, das auf der Quittung oder Rechnung angegeben ist, die zur Inanspruchnahme der Garantie vorgelegt werden muss.

Die Garantiezeit für dieses Produkt variiert je nach den gesetzlichen Bestimmungen des Landes, in dem es gekauft wurde. Bitte informieren Sie sich über die im Land des Kaufs geltenden Vorschriften.

⚠ VON DER GARANTIE AUSGESCHLOSSEN

Es gibt bestimmte Ursachen, die von der Garantie ausgeschlossen sind, wie z. B.:

- ⊗ Im Falle eines Transportfehlers muss das Transportunternehmen innerhalb von 24 Stunden nach der Lieferung benachrichtigt werden.
- ⊗ Bruch oder Beschädigung durch schlechtes Wetter.
- ⊗ Fehlerhafte Montage, unsachgemäße Verwendung und daraus resultierende Folgen.

Darüber hinaus können Sie die vollständige Liste dieser drei Punkte durch Scannen des QR-Codes auf der Verpackung einsehen.

**FÜR DIE MONTAGE
ERFORDERLICHE
WERKZEUGE**

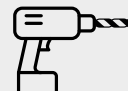

ΕΓΧΕΙΡΙΔΙΟ ΧΡΗΣΤΗ

Πριν ξεκινήσουμε...

Θέλουμε να σας ευχαριστήσουμε που επιλέξατε ένα από τα προϊόντα μας. Η διαδικασία συναρμολόγησης μπορεί να απαιτεί λίγη υπομονή και χρόνο, αλλά μην ανησυχείτε, είμαστε εδώ για να σας ενθαρρύνουμε! 😊

Μόλις τελειώσετε σκεφτείτε την ικανοποίηση και την υπερηφάνεια που θα νιώσετε όταν θα δείτε το τελικό σας έργο και θα ξέρετε ότι το κάνατε μόνοι σας. Επίσης, με τη συναρμολόγησή του συμβάλλετε στο περιβάλλον. Πώς; Καθώς δεν παραδίδεται πλήρως συναρμολογημένο, χρησιμοποιείται λιγότερη συσκευασία, πράγμα που σημαίνει λιγότερα απορρίμματα και λιγότερα απόβλητα. Με αυτόν τον τρόπο κάθε προϊόν καταλαμβάνει λιγότερο χώρο και επομένως αξιοποιείτε στο έπακρο τα μέσα μεταφοράς, μειώνοντας έτσι τις εκπομπές CO₂.

Επομένως, με αυτή την αγορά κάνετε μια συνειδητή επιλογή για την προστασία του πλανήτη μας.

Προχωρήστε λοιπόν και πιάστε δουλειά!



Για τη συναρμολόγηση του προϊόντος απαιτούνται δύο άτομα



Ο μέσος χρόνος συναρμολόγησης μπορεί να κυμαίνεται μεταξύ 2 ωρών για τα μικρότερα μοντέλα και 10-12 ωρών για τα μεγαλύτερα

🗨 ΣΥΣΤΑΣΕΙΣ ΠΡΙΝ ΑΠΟ ΤΗ ΣΥΝΑΡΜΟΛΟΓΗΣΗ

Το προϊόν δεν έχει σχεδιαστεί για να εγκατασταθεί απευθείας στο γκαζόν. Συνιστούμε τη συναρμολόγηση σε επίπεδη και σταθερή ξύλινη βάση, σε επίπεδο τσιμεντένιο δάπεδο ή σε τσιμεντοποιημένα τούβλα ή τούβλα.

Εάν γίνει μια τσιμεντένια βάση, είναι σημαντικό να έχει κλίση προς τις άκρες για να αποφευχθεί η εισροή νερού.

Είναι πολύ σημαντικό να στερεωθεί το προϊόν στο δάπεδο. Δεν περιλαμβάνονται βίδες ή άλλα μέρη που είναι απαραίτητα για την αγκύρωση.

🔑 ΣΥΝΤΗΡΗΣΗ

Η οροφή πρέπει να διατηρείται απαλλαγμένη από σκουπίδια, καθώς το βάρος στην κορυφή μπορεί να προκαλέσει ζημιά στο προϊόν σας.

Μην αποθηκεύετε χημικά, εύφλεκτα ή/και διαβρωτικά προϊόντα στο εσωτερικό της.

⚙ ΕΓΓΥΗΣΗ

Αυτό το προϊόν κατασκευάζεται με τα καλύτερα υλικά και κάτω από αυστηρούς ποιοτικούς ελέγχους και πρότυπα. Εάν εντοπίσετε οποιοδήποτε πρόβλημα με το προϊόν που αγοράσατε, παρακαλούμε επικοινωνήστε με το τμήμα εξυπηρέτησης πελατών μας στον αριθμό τηλεφώνου και στη διεύθυνση ηλεκτρονικού ταχυδρομείου που αναγράφονται στο οπισθόφυλλο του παρόντος εγχειριδίου οδηγιών χρήσης.

Η εγγύηση ισχύει από την ημερομηνία αγοράς που αναγράφεται στην απόδειξη ή το τιμολόγιο, τα οποία πρέπει να προσκομιστούν για να κάνετε χρήση της εγγύησης.

Η περίοδος εγγύησης για αυτό το προϊόν ποικίλλει ανάλογα με τους νομικούς κανονισμούς που ισχύουν στη χώρα αγοράς. Για περισσότερες πληροφορίες ανατρέξτε στους κανονισμούς που ισχύουν στη χώρα αγοράς.

⚙ ΕΞΑΙΡΟΥΝΤΑΙ ΑΠΟ ΤΗΝ ΕΓΓΥΗΣΗ

Υπάρχουν ορισμένες αιτίες που εξαιρούνται από την εγγύηση, όπως:

- ⊗ Εάν υπάρχει μη συμμόρφωση κατά τη μεταφορά, το πρακτορείο μεταφοράς πρέπει να ειδοποιηθεί εντός 24 ωρών από την παράδοση.
- ⊗ Σπάσιμο ή ζημιά που προκαλείται από κακές καιρικές συνθήκες.
- ⊗ Λανθασμένη συναρμολόγηση, λανθασμένη χρήση και συνέπειες που απορρέουν από αυτήν.

Επιπλέον, μπορείτε να συμβουλευτείτε τον πλήρη κατάλογο αυτών των τριών, σαρώνοντας το QR στο κουτί.

ΕΡΓΑΛΕΙΑ ΠΟΥ ΑΠΑΙΤΟΥΝΤΑΙ ΓΙΑ ΤΗ ΣΥΝΑΡΜΟΛΟΓΗΣΗ

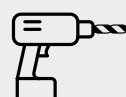

MANUALE DI ISTRUZIONI

Prima di iniziare...

Vogliamo ringraziarvi per aver scelto uno dei nostri prodotti. Il processo di assemblaggio può richiedere un po' di pazienza e di tempo, ma non preoccupatevi, siamo qui per incoraggiarvi! 😊

Una volta terminato, pensate alla soddisfazione e all'orgoglio che proverete quando vedrete il vostro lavoro finito e saprete di averlo fatto da soli. Inoltre, assemblandolo, darete un contributo all'ambiente: poiché non viene consegnato completamente assemblato, vengono utilizzati meno imballaggi, il che significa meno rifiuti e meno scarti. In questo modo ogni prodotto occupa meno spazio e quindi si sfruttano al meglio i mezzi di trasporto, riducendo così le emissioni di CO₂. Pertanto, con questo acquisto fate una scelta consapevole per proteggere il nostro pianeta.

Quindi, andate avanti e mettetevi al lavoro!



Per assemblare il prodotto sono necessarie due persone



Il tempo medio di montaggio può variare da 2 ore per i modelli più piccoli a 10-12 ore per quelli più grandi

🗨️ RACCOMANDAZIONI PRIMA DEL MONTAGGIO

Il prodotto non è stato progettato per essere installato direttamente sul prato. Si consiglia il montaggio su una base di legno piana e solida, su un pavimento di cemento piatto o su mattoni o blocchi cementati.

Se si realizza una base in cemento, è importante che sia inclinata verso i bordi per evitare l'ingresso di acqua.

È molto importante fissare il prodotto al suolo. Non sono incluse viti o altre parti necessarie per l'ancoraggio.

🔧 MANUTENZIONE

Il tetto deve essere mantenuto libero da detriti, poiché il peso sulla parte superiore può danneggiare il prodotto.

Non conservare all'interno prodotti chimici, combustibili e/o corrosivi.

🛡️ GARANZIA

Questo prodotto è realizzato con i migliori materiali e in base a rigorosi controlli e standard di qualità. Se si riscontrano problemi con il prodotto acquistato, si prega di contattare il servizio clienti al numero di telefono e all'indirizzo e-mail riportati sul retro della copertina di questo manuale di istruzioni.

La garanzia è valida a partire dalla data di acquisto riportata sullo scontrino o sulla fattura, che deve essere presentata per usufruire della garanzia.

Il periodo di garanzia per questo prodotto varia a seconda delle norme legali applicabili nel paese di acquisto. Per maggiori informazioni, consultare le norme vigenti nel Paese di acquisto.

⚠️ ESCLUSE DALLA GARANZIA

Vi sono alcune cause che sono escluse dalla garanzia, come ad esempio:

- ⌕ In caso di non conformità al trasporto, l'agenzia di trasporto deve essere informata entro 24 ore dalla consegna.
- ⌕ Rotture o danni causati da intemperie.
- ⌕ Montaggio non corretto, uso non corretto e conseguenze derivanti da questo.

Inoltre, è possibile consultare l'elenco completo di questi tre elementi scansionando il QR sulla scatola.

**STRUMENTI
NECESSARI PER IL
MONTAGGIO**



NÁVOD NA POUŽITIE

Predtým, ako začneme...

Ďakujeme za kúpu jedného z našich produktov. Proces montáže môže vyžadovať trochu trpezlivosti a času, no my sme tu na to, aby sme vám s tým pomohli! 😊

Myslíte na uspokojenie a pýchu, ktorú pocítite pri pohľade na vlastnoručne dokončenú prácu. Navyše, montážou pomáhate životnému prostrediu. Ako? Dodanie čiastočne rozloženého produktu vyžaduje menej obalového materiálu a menej odpadu. Týmto spôsobom sa obmedzuje aj veľkosť produktov, a tým sa prispieva k úplnému využitiu priestoru v dopravných prostriedkoch a zníženiu CO₂.

Táto kúpa reprezentuje vašu uvedomelú voľbu na ochranu planéty.

Teraz sa už môžete pustiť do práce!



Na montáž produktu sú potrebné dve osoby



Čas montáže sa pohybuje medzi 2 hodinami, v prípade malých modelov, a 10 – 12 hodinami pri najväčších produktoch

ODPORÚČANIA PRED ZAČATÍM MONTÁŽE

Výrobok nie je určený na inštaláciu priamo na trávnik. Odporúčame montáž na rovnú a pevný drevený podklad, rovnú podlahu z betónu, tehliel či tvárnic.

Pri stavbe betónového podkladu je dôležité jeho naklonenie smerom k okrajom, aby sa vyhlo hromadeniu vody.

Je dôležité pripevniť produkt k podkladu. Balenie neobsahuje skrutky ani iné súčiastky na jeho ukotvenie.

ÚDRŽBA

Udržujte strechu produktu bez záťaže, pretože tá by mohla spôsobiť jej poškodenie.

Vo vnútri produktu neskladujte chemikálie, horľavé a/alebo oxidačné látky.

ZÁRUKA

Tento produkt je vyrobený z najlepších materiálov podľa prísnych kontrol a štandardov kvality. Ak zistíte akékoľvek problémy so zakúpeným výrobkom, obráťte sa na oddelenie služieb zákazníkom na telefónnom čísle a e-mailovej adrese uvedenej na zadnej strane tohto návodu na použitie.

Záruka je platná od dátumu nákupu uvedeného na účtenke alebo faktúre, ktorú je potrebné predložiť na uplatnenie záruky.

Záručná doba na tento výrobok sa líši v závislosti od právnych predpisov platných v krajine nákupu. Ďalšie informácie nájdete v právnych predpisoch príslušnej krajiny.

SÚ ZO ZÁRUKY VYLÚČENÉ

Existujú určité príčiny, ktoré sú zo záruky vylúčené, ako napríklad:

- ⊗ Ak sa vyskytne nehoda pri preprave, prepravná spoločnosť musí byť informovaná do 24 hodín od doručenia.
- ⊗ Rozbitie alebo poškodenie spôsobené nepriaznivým počasím.
- ⊗ Nesprávna montáž, nesprávne používanie a ich dôsledky.

Kompletný zoznam týchto prípadov si môžete pozrieť naskenovaním kódu QR na škatuli.

**NÁRADIE
POTREBNÉ NA
MONTÁŽ**



PRIRUČNIK

Prije no što započnete...

Hvala vam što ste odabrali jedan od naših proizvoda. Za proces montaže možda je potrebno nešto strpljenja i vremena, ali ne brinite se: ovdje smo da vam pomognemo! 😊

Pomislite na zadovoljstvo i ponos koje ćete osjetiti kad završite i vidite da je vaš posao gotov i da ste ga sami napravili. Osim toga, montažom pomažete okolišu. Kako? S obzirom na to da se ne isporučuje u gotovom stanju, troši se manje ambalaže, što znači manje otpadaka i smeća. Na ovaj način svaki proizvod zauzima manje prostora, zbog čega se prijevozna sredstva maksimalno iskorištavaju, čime se smanjuje emisija CO₂.

Stoga vi ovom kupnjom svjesno odlučujete zaštititi naš planet.

A sada... Na posao!



Za montažu proizvoda potrebne su dvije osobe



Prosječno vrijeme montaže može biti od 2 h za najmanje modele do 10-12 h za najveće

PREPORUKE PRIJE MONTAŽE

Proizvod nije namijenjen za travnjak kao izravnu podlogu. Preporučujemo montažu na čvrstoj, ravnoj drvenoj podlozi, ravnoj betonskoj podlozi ili podlozi od cementiranih opeka ili ploča.

Ako se radi betonska platforma važno je da ona ima nagib prema rubovima kako bi se izbjegao prodor vode.

Vrlo je važno pričvrstiti proizvod za pod. Nisu uključeni vijci ni drugi dijelovi potrebni za pričvršćivanje.

ODRŽAVANJE

Krov se mora čistiti od otpadaka jer težina u gornjem dijelu može oštetiti vaš proizvod.

Unutra nemojte skladištiti kemijske, zapaljive i/ili korozivne proizvode.

JAMSTVO

Ovaj proizvod izrađen je od vrhunskih materijala i pod strogim kontrolama i standardima kvalitete. U slučaju bilo kakvih mana na kupljenom proizvodu, obratite se službi za kupce na broj telefona i e-mail koji su navedeni na poledini ovog priručnika za uporabu.

Jamstvo vrijedi od datuma kupnje koji se nalazi na potvrdi ili računu koji je potrebno predložiti za korištenje jamstva.

Razdoblje jamstva za ovaj proizvod varira ovisno o zakonskim propisima koji su na snazi u zemlji kupnje. Za više informacija proučite važeće propise.

U JAMSTVO NISU UKLJUČENI

Neki uzroci nisu uključeni u jamstvo, kao:

- ⊗ U slučaju neadekvatnog transporta, treba obavijestiti agenciju za prijevoz prije no što prođu 24 sata od isporuke.
- ⊗ Lomovi ili oštećenja uzrokovani vremenskim nepogodama.
- ⊗ Loša montaža, nepravilna uporaba i njihove posljedice.

Osim ova tri, možete pregledati cijeli popis skeniranjem QR koda na kutiji.

**ALAT POTREBAN
ZA MONTAŽU**



NÁVOD K POUŽITÍ

Než začnete...

Chtěli bychom vám poděkovat, že jste si vybrali jeden z našich produktů. Montáž může vyžadovat trochu trpělivosti a času, ale nebojte se, jsme tu, abychom vám pomohli! 😊

Představte si, jaké uspokojení a hrdost pocítíte, až uvidíte produkt smontovaný a budete vědět, že jste jej smontovali vy sami. Navíc tím šetříte i životní prostředí. Proč? Díky tomu, že produkty nejsou dodávány kompletně smontované, spotřebovává se méně obalů, což znamená méně odpadu a zbytků. Každý výrobek tak zabírá méně místa a proto se dopravní prostředky maximálně využijí, čímž se snižují emise CO₂.

Tímto nákupem se tedy vědomě rozhodujete chránit naši planetu.

Tak a nyní... Jdeme na to!



K sestavení produktu jsou zapotřebí dvě osoby



Průměrná doba montáže může být 2 hodiny u nejmenších modelů a 10-12 hodin u největších

DOPORUČENÍ PŘED MONTÁŽÍ

Výrobek není určen k instalaci přímo na trávník. Doporučujeme jej umístit na pevný a rovný dřevěný podklad, rovnou cementovou podlahu nebo tmelené cihly či bloky.

Pokud se jedná o cementovou plošinu, je důležité, aby se svažovala směrem k okrajům, aby se zabránilo vniknutí vody. Je velmi důležité připevnit výrobek k zemi. Neobsahuje šrouby ani jiné díly nutné k jeho ukotvení.

ÚDRŽBA

Na střeše nesmí zůstat žádné předměty, protože její zatížení by mohlo poškodit váš produkt. Neskladujte uvnitř chemické, hořlavé ani korozivní produkty.

ZÁRUKA

Tento produkt je vyroben z nejlepších materiálů a byl podroben přísné kontrole kvality a norem. V případě, že u zakoupeného produktu zjistíte jakékoliv závady, kontaktujte prosím zákaznický servis na telefonním čísle a emailu, které jsou uvedeny na zadní straně tohoto návodu.

Záruka je platná od data nákupu uvedeného na stvrzence nebo faktuře, kterou je nutné předložit pro její uplatnění.

Záruční doba pro tento výrobek se liší v závislosti na právních předpisech platných v zemi nákupu. Další informace naleznete v aktuálních předpisech dané země.

ZÁRUKA SE NEUPLATŇUJE V NÁSLEDUJÍCÍCH PŘÍPADECH

Existují určité případy, kdy záruku nelze uplatnit, například:

- ⊙ V případě, že nejste spokojeni s přepravou, je nutné tuto skutečnost oznámit přepravní kanceláři do 24 hodin od doručení.
- ⊙ Při rozbití nebo poškození způsobeného nepřízní počasí
- ⊙ V případě špatného provedení montáže, nesprávného použití a z toho vyplývajících důsledků.

Kromě těchto tří důvodů existují další, jejichž kompletní seznam si můžete přečíst po naskenování QR kódu na krabici.

**NÁŘADÍ POTŘEBNÉ
K MONTÁŽI**

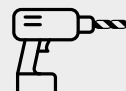

NAVODILA ZA UPORABO

Pred začetkom...

Želimo se vam zahvaliti, ker ste izbrali enega od naših izdelkov. Postopek montaže bo morda zahteval nekaj potrpljenja in časa, a ne skrbite, tukaj smo, da vam pomagamo! 😊

Ko končate z montažo, pomislite na zadovoljstvo in ponos, ki ju boste občutili, ko boste videli svoje delo dokončali in vse naredili sami. Poleg tega z montažo pozitivno prispevate k okolju. Kako? Ker izdelek ni dostavljen popolnoma montiran, se porabi manj embalaže, kar pomeni manj ostankov in manj odpadkov. Na ta način vsak izdelek zasede manj prostora in je zato prevozno sredstvo kar se da izkoriščeno, s čimer se zmanjšajo emisije CO₂.

Zato ste se s tem nakupom zavestno odločili za zaščito našega planeta.

Zdaj pa ... Kar na delo!



Za montažo izdelka sta potrebni dve osebi



Povprečni čas montaže je lahko med 2 urama za manjše modele in 10-12 ur za največje modele

PRIPOROČILA PRED MONTAŽO

Izdelek ni zasnovan za namestitev neposredno na trato. Priporočamo, da se montaža opravi na trdni, ravni leseni podlagi, ravnih cementnih tleh ali na cementiranih opekah ali blokih.

Če se izdelka cementna ploščad, je pomembno, da je nagnjena proti robovom, da se prepreči udor vode.

Zelo pomembno je, da izdelek pritrдите na tla. Ne vključuje vijakov ali drugih delov, potrebnih za njegovo pritrđitev.

VZDRŽEVANJE

Na strehi ne sme biti ostankov, saj lahko njihova teža uniči vaš izdelek.

V notranjosti ne shranjujte kemičnih, gorljivih in/ali jedkih izdelkov.

GARANCIJA

Ta izdelek je narejen iz najboljših materialov ter pod strogimi nadzori in standardi glede kakovosti. V primeru, da pri kupljenem izdelku zaznate kakršne koli nevspečnosti, se obrnite na službo za pomoč strankam ter pokličite na telefonsko številko ali pišite na e-poštni naslov, ki sta navedena na zadnji platnici teh navodil za uporabo.

Garancija velja od datuma nakupa, ki je naveden na računu, ki ga morate predložiti za uveljavljanje garancije.

Garancijska doba za ta izdelek se razlikuje glede na pravne predpise, ki veljajo v državi nakupa. Za več informacij si oglejte trenutne predpise v državi nakupa.

IZ GARANCIJE JE IZVZETO NASLEDNJE

Obstajajo določeni vzroki, ki so izključeni iz garancije, kot so:

- ⊗ Če pride do neskladij pri prevozu, je treba o tem obvestiti prevoznika v 24 urah po dostavi izdelka.
- ⊗ Zlomi ali poškodbe zaradi neugodnih vremenskih razmer
- ⊗ Slaba montaža, nepravilna uporaba in posledice, ki izhajajo iz tega.

Poleg teh treh vzrokov si lahko ogledate celoten seznam tako, da skenirate kodo QR na škatli.

**ORODJE,
POTREBNO ZA
MONTAŽO**



BRUKSANVISNING

Innan du börjar...

Vi vill tacka dig för att du valt en av våra produkter. Monteringsprocessen kan kräva lite tålamod och tid, men oroa dig inte, vi är här för att heja på dig! 😊

När du är klar, tänk på tillfredsställelsen och stoltheten du kommer att känna när du ser ditt färdiga arbete och veta att du gjorde det själv. Dessutom bidrar du till miljön genom att ställa in den. Som? Genom att inte levereras färdigmonterad går det åt mindre förpackningar, vilket innebär mindre avfall och mindre förstörelse. På så sätt tar varje produkt upp mindre utrymme, vilket maximerar användningen av transportresurser och därigenom minskar CO₂-utsläppen.

Därför gör du med detta köp ett medvetet val för att skydda vår planet.

Nu ja... Varsågod och börja jobba!



**Två personer krävs
för att montera
produkten**



**Den genomsnittliga monterings tiden
kan vara mellan 2 timmar för de minsta
modellerna och 10-12 timmar för de största**

REKOMMENDATIONER FÖRE MONTERING

Produkten är inte konstruerad för att installeras direkt på gräsmattan. Vi rekommenderar montering på en jämn och fast träbotten, ett plant golv av cement eller cementerade tegel eller block.

Om en betongplattform byggs är det viktigt att den sluttar mot kanterna för att förhindra att vatten kommer in.

Det är mycket viktigt att säkra produkten till marken. Det inkluderar inte skruvar eller andra delar som behövs för förankring.

UNDERHÅLL

Taket bör hållas fritt från skräp, eftersom vikten ovanpå kan skada din produkt.

Förvara inte kemikalier, bränslen och/eller frätande ämnen inuti.

GARANTI

Denna produkt är tillverkad med de finaste materialen och under strikta kvalitetskontroller och standarder. Om du märker några problem med den köpta produkten, vänligen kontakta kundtjänst på telefonnumret och e-postadressen som anges på baksidan av denna bruksanvisning.

Garantin gäller från inköpsdatumet som visas på kvittot eller fakturan, som måste visas upp för att göra anspråk på garantin.

Garantiperioden för denna produkt varierar beroende på de lagliga regler som gäller i inköpslandet. Se ditt lands aktuella bestämmelser för mer information.

FÖLJANDE ÄR EXKLUDERADE FRÅN GARANTIN

Det finns vissa orsaker som är uteslutna från garantin som:

- ⊗ Om det finns en avvikelse i transporten ska det meddelas transportverket före kl. 24 timmar hargått sedan leverans.
- ⊗ Sprickor eller skador orsakade av dåligt väder.
- ⊗ Dålig montering, felaktig användning och konsekvenser till följd av detta.

Dessutom kan du kontrollera hela listan över dessa tre genom att skanna QR-koden på rutan.

**VERKTYG BEHÖVS
FÖR MONTERING**



KULLANIM KILAVUZU

Başlamadan önce...

Ürünlerimizden birini tercih ettiğiniz için teşekkür ederiz. Montaj süreci biraz sabır ve zaman gerektirebilir, ama endişelenmeyin, sizi desteklemek için buradayız! 😊

İşiniz bittiğinde, bitmiş işinizi gördüğünüzde ve bunu kendiniz yaptığınızı bildiğinizde hissedeceğiniz memnuniyeti ve gururu düşünün. Ayrıca bunu kurarak çevreye de katkıda bulunuyorsunuz. Gibi? Tamamen monte edilmiş halde teslim edilmemesi sayesinde daha az ambalaj kullanılıyor, bu da daha az atık ve bozulma anlamına geliyor. Bu sayede her ürün daha az yer kaplıyor, ulaşım kaynaklarının en iyi şekilde kullanılması sağlanıyor, dolayısıyla CO2 emisyonu azalıyor.

Dolayısıyla bu alışverişinizle gezegenimizi korumak adına bilinçli bir tercihte bulunuyorsunuz.

Evet şimdi... Hadi, işe koyul!



Ürünün montajı için iki kişiye ihtiyaç vardır.



En küçük modellerde ortalama montaj süresi 2 saat, en büyük modellerde ise 10-12 saat arasında değişebiliyor.

🗨 MONTAJ ÖNCESİ ÖNERİLER

Ürün doğrudan çimlerin üzerine monte edilmek üzere tasarlanmamıştır. Bir montaj öneriyoruz düz ve sağlam ahşap taban, çimento veya çimentolu tuğla veya bloklardan yapılmış düz bir zemin.

Beton bir platform inşa edilecekse, suyun içeri girmesini önlemek için kenarlara doğru eğimli olması önemlidir.

Ürünün zemine sabitlenmesi çok önemlidir. İçerisinde sabitleme için gerekli vida ve diğer parçalar bulunmamaktadır.

🔧 BAKIM

Çatı, ürününüze zarar verebileceğinden, molozlardan temiz tutulmalıdır.

İçerisinde kimyasal, yakıt ve/veya aşındırıcı maddeler saklamayın.

🛡 GARANTİSİ

Bu ürün en iyi malzemelerle, sıkı kalite kontrolleri ve standartları altında üretilmiştir. Satın aldığınız üründe herhangi bir sorun fark ederseniz, lütfen bu kullanım kılavuzunun arka kapağında belirtilen telefon numarası ve e-posta adresinden müşteri hizmetleriyle iletişime geçin.

Garanti, garantiyi talep etmek için ibraz edilmesi gereken fiş veya faturada belirtilen satın alma tarihinden itibaren geçerlidir.

Bu ürünün garanti süresi, satın alındığı ülkede geçerli olan yasal düzenlemelere bağlı olarak değişiklik göstermektedir.

Daha fazla bilgi için lütfen ülkenizin geçerli yönetmeliklerine bakın.

⚠ KG AŞAĞIDAKİLER GARANTİ DİŞİNDADIR

Garanti kapsamı dışında kalan bazı nedenler şunlardır:

- ⊗ Taşımada bir uygunsuzluk varsa, taşıma acentesine önceden bildirilmelidir. Teslimatın üzerinden 24 saat geçti.
- ⊗ Olumsuz hava koşullarından kaynaklanan kırılmalar veya hasarlar.
- ⊗ Kötü montaj, yanlış kullanım ve bundan kaynaklanan sonuçlar.

Ayrıca kutunun üzerindeki QR kodunu taratarak bu ürünün tam listesini görebilirsiniz.

**MONTAJ İÇİN
GEREKLİ ARAÇLAR**



MANUALI I UDHËZIMEVE

Innan du börjar...

Duam t'ju falënderojmë që zgjodhët një nga produktet tona. Procesi i montimit mund të kërkojë pak durim dhe kohë, por mos u shqetësoni, ne jemi këtu për t'ju mbështetur! 😊

Pasi të keni mbaruar, mendoni për kënaqësinë dhe krenarinë që do të ndjeni duke parë punën tuaj të përfunduar dhe duke ditur se e keni bërë vetë. Plus, duke e montuar, po i jepni një kontribut mjedisit. Si ndodh kjo? Meqenëse nuk dorëzohet plotësisht i montuar, përdoret më pak paketim, që do të thotë më pak mbeturina dhe më pak mbeturina. Në këtë mënyrë, çdo produkt zë më pak hapësirë, duke maksimizuar kostot e transportit, duke zvogëluar kështu emetimet e CO2.

Prandaj, me këtë blerje ju po bëni një zgjedhje të vetëdijshme për të mbrojtur planetin tonë.

Tani po... Vazhdo dhe fillo punën!



Duhet dy persona për të montuar produktin



Koha mesatare e montimit mund të jetë midis 2 orësh për modelet më të vogla dhe 10-12 orësh për ato më të mëdhatë

REKOMANDIME PARA MONTIMIT

Produkti nuk është projektuar për t'u instaluar direkt në lëndinë. Ne rekomandojmë montimin e tij në një bazë druri e niveluar dhe e fortë, një dysheme e sheshtë prej çimentoje ose tullash ose blloqesh të çimentuara. Nëse ndërtohet një platformë betoni, është e rëndësishme që ajo të anojë drejt skajeve për të parandaluar hyrjen e ujit. Është shumë e rëndësishme ta siguron produktin në dysheme. Vidat dhe pajisjet e tjera të ankorimit nuk përfshihen.

MIRËMBAJTJE

Çatia duhet të mbahet e pastër nga mbeturinat, pasi pesha sipër mund të dëmtojë produktin tuaj. Mos ruani kimikate, karburante dhe/ose gërryes brenda.

GARANCI

Ky produkt është prodhuar me materialet më të mira dhe përbush kontrollat dhe standardet strikte të cilësisë. Nëse keni ndonjë problem me produktin e blerë, ju lutemi kontaktoni shërbimin ndaj klientit në numrin e telefonit dhe adresën e email-it të listuara në kopertinën e pasme të këtij manuali udhëzimesh.

Garancia është e vlefshme nga data e blerjes, siç tregohet në faturë ose kupon, të cilat duhet të paraqiten për të përfituar nga garancia.

Periodha e garancisë për këtë produkt ndryshon në varësi të rregulloreve ligjore në fuqi në vendin e blerjes. Ju lutemi të konsultoheni me rregulloret aktuale të vendit tuaj për më shumë informacion.

NGA GARANCIA PËRJASHTOHEM MË POSHTË

Ekzistojnë disa shkaqe që përjashtohen nga garancia, siç janë:

- ⊗ Nëse ka ndonjë mospërputhje në transport, kjo duhet t'i komunikohet agjencisë së transportit përpara se Kanë kaluar 24 orë nga dorëzimi.
- ⊗ Thyerje ose dëmtime të shkaktuara nga moti i keq.
- ⊗ Montim i dobët, përdorim i gabuar dhe pasojat që vijnë si pasojë.

Për më tepër, mund ta kontrolloni listën e plotë të këtyre të trejave duke skanuar kodin QR në kuti.

MJETE TË NEVOJSHME PËR MONTIM

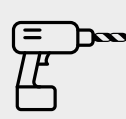

РУКОВОДСТВО ПО ЭКСПЛУАТАЦИИ

Прежде чем мы начнем...

Благодарим вас за выбор одного из наших продуктов. Сборка может потребовать немного терпения и времени, но не волнуйтесь, мы готовы помочь! 😊

Закончив, подумайте о том удовлетворении и гордости, которые вы испытаете, увидев свой готовый проект и осознавая, что сделали его своими руками. Кроме того, собирая его, вы вносите вклад в защиту окружающей среды. Как? Поскольку он не поставляется в полностью собранном виде, используется меньше упаковки, а значит, меньше отходов. Таким образом, каждый продукт занимает меньше места, что позволяет максимально эффективно использовать транспортные ресурсы и сокращать выбросы CO₂.

Поэтому, совершая эту покупку, вы делаете осознанный выбор в пользу защиты нашей планеты.

Итак... приступим к работе!



Для сборки изделия требуются два человека



Среднее время сборки может составлять от 2 часов для самых маленьких моделей до 10–12 часов для самых больших

🗨 РЕКОМЕНДАЦИИ ПО ПРЕДВАРИТЕЛЬНОЙ СБОРКЕ

Изделие не предназначено для установки непосредственно на траву. Мы рекомендуем сборку на ровное и прочное деревянное основание, ровный пол из цемента или сцементированных кирпичей или блоков. Если сделана цементная платформа, важно, чтобы она имела уклон к краям, чтобы предотвратить попадание воды. Очень важно надежно закрепить изделие на полу. Винты и другие необходимые для крепления детали в комплект не входят.

🔧 ОБСЛУЖИВАНИЕ

Крышу необходимо очищать от мусора, так как ее вес может повредить изделие.

Не храните внутри химикаты, топливо и/или едкие вещества.

🛡 ГАРАНТИЯ

Этот продукт изготовлен из лучших материалов и соответствует строгим стандартам качества. Если вы обнаружите какие-либо проблемы с приобретенным вами продуктом, пожалуйста, свяжитесь со службой поддержки клиентов по номеру телефона и адресу электронной почты, указанным на задней обложке данного руководства.

Гарантия действует с даты покупки, указанной в чеке или счете-фактуре, которые необходимо предъявить для использования гарантии.

Гарантийный срок на данный продукт зависит от действующего законодательства страны приобретения. Для получения дополнительной информации ознакомьтесь с действующим законодательством вашей страны.

⚠ ИЗ ГАРАНТИИ НЕ РАСПРОСТРАНЯЮТСЯ

Гарантия не распространяется на определенные причины, например:

- ⊗ Если обнаружено несоответствие при транспортировке, необходимо уведомить транспортное агентство заранее. Прошло 24 часа с момента доставки.
- ⊗ Поломки или повреждения, вызванные непогодой.
- ⊗ Неправильная сборка, неправильное использование и вытекающие из этого последствия.

Кроме того, вы можете ознакомиться с полным списком этих трех товаров, отсканировав QR-код на коробке.

**ИНСТРУМЕНТЫ,
НЕОБХОДИМЫЕ
ДЛЯ СБОРКИ**

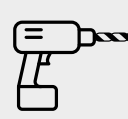

INSTRUKCJA OBSŁUGI

Zanim zaczniemy...

Dziękujemy za wybór jednego z naszych produktów. Proces montażu może wymagać trochę cierpliwości i czasu, ale nie martw się, jesteśmy tu, aby Ci pomóc! 😊

Po skończeniu, pomyśl o satysfakcji i dumie, jakie poczujesz, widząc swój ukończony projekt i wiedząc, że zrobiłeś go sam. Co więcej, montując go, przyczyniasz się do ochrony środowiska. W jaki sposób? Ponieważ produkt nie jest dostarczany w stanie zmontowanym, zużywa się mniej opakowań, co przekłada się na mniej odpadów. W ten sposób każdy produkt zajmuje mniej miejsca, optymalnie wykorzystując zasoby transportowe i redukując emisję CO2.

Dlatego dokonując tego zakupu świadomie decydujesz o ochronie naszej planety.

No to teraz... do dzieła!



Do montażu produktu potrzebne są dwie osoby



Średni czas montażu może wynosić od 2 godzin w przypadku najmniejszych modeli do 10-12 godzin w przypadku największych.

🗨 ZALECENIA PRZED MONTAŻEM

Produkt nie jest przeznaczony do montażu bezpośrednio na trawie. Zalecamy montaż na

równą i stabilną drewnianą podstawą, płaską podłogą z cementu lub cegieł lub bloczków cementowych.

Jeżeli wykonuje się platformę cementową, ważne jest, aby była nachylona w kierunku krawędzi, aby zapobiec przedostawaniu się wody.

Bardzo ważne jest, aby przymocować produkt do podłogi. Śruby i inne elementy niezbędne do zakotwiczenia nie są dołączone.

🔧 KONSERWACJA

Dach musi być czysty, ponieważ ciężar na górze może uszkodzić produkt.

Nie należy przechowywać wewnątrz pojemnika środków chemicznych, paliw i/lub materiałów żrących.

🛡 GWARANCJA

Ten produkt został wyprodukowany z najwyższej jakości materiałów i zgodnie z rygorystycznymi standardami kontroli jakości. W przypadku zauważenia jakichkolwiek problemów z zakupionym produktem, prosimy o kontakt z działem obsługi klienta pod numerem telefonu i adresem e-mail podanymi na tylnej okładce niniejszej instrukcji obsługi.

Gwarancja obowiązuje od daty zakupu podanej na paragonie lub fakturze, które należy okazać w celu skorzystania z gwarancji.

Okres gwarancji na ten produkt różni się w zależności od przepisów prawnych obowiązujących w kraju zakupu. Aby uzyskać więcej informacji, zapoznaj się z obowiązującymi przepisami w swoim kraju.

⚙ GWARANCJA NIE OBEJMUJE

Istnieją pewne przyczyny wyłączone z gwarancji, takie jak:

- ⌚ W przypadku stwierdzenia niezgodności w transporcie należy powiadomić o tym fakcie przewoźnika przed Minutą 24 godziny od dostawy.
- ⌚ Zniszczenia lub uszkodzenia spowodowane niekorzystnymi warunkami pogodowymi.
- ⌚ Niewłaściwy montaż, nieprawidłowe użytkowanie i wynikające z tego konsekwencje.

Dodatkowo możesz zapoznać się z pełną listą tych trzech pozycji, skanując kod QR znajdujący się na pudełku.

MJETE TË
NEVOJSHME PËR
MONTIM

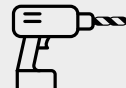

HASZNÁLATI UTASÍTÁS

Mielőtt elkezdenénk...

Köszönjük, hogy termékeink egyikét választotta. Az összeszerelési folyamat némi türelmet és időt igényelhet, de ne aggódjon, itt vagyunk, hogy segítsünk! 😊

Miután elkészültél, gondolj arra az elégedettségre és büszkeségre, amit a kész projekted láttán érzel, és tudod, hogy magad készítetted. Ráadásul az összeszereléssel hozzájárulsz a környezethez. Hogyan? Mivel nem teljesen összeszerelve szállítjuk, kevesebb csomagolóanyagot használunk, ami kevesebb hulladékot jelent. Így minden termék kevesebb helyet foglal, így a lehető legjobban kihasználható a szállítási erőforrások és csökkenthető a CO₂-kibocsátás.

Tehát ezzel a vásárlással tudatos döntést hozol bolygónk védelme érdekében.

Most pedig... lássunk munkához!



A termék összeszereléséhez két ember szükséges



Az átlagos összeszerelési idő a legkisebb modellek esetében 2 órától a legnagyobbak esetében 10-12 óráig terjedhet

🗨 ÖSSZESZERELÉS ELŐTTI JAVASLATOK

A termék nem közvetlenül fűre történő telepítésre készült. Javasoljuk az összeszerelést egy sík és szilárd fa alap, cementből vagy cementált téglából vagy blokkokból készült sík padló.

Ha cementplatformot készítenek, fontos, hogy az a szélek felé lejtjen, hogy megakadályozza a víz bejutását.

Nagyon fontos a termék padlóhoz rögzítése. A csavarok és a rögzítéshez szükséges egyéb alkatrészek nem tartozékok.

🔧 KARBANTARTÁS

A tetőt tisztán kell tartani a törmeléktől, mivel a tetején lévő súly károsíthatja a terméket.

Ne tároljon vegyszereket, üzemanyagokat és/vagy maró anyagokat a készülékben.

🛡 GARANCIA

Ez a termék a legkiválóbb minőségű anyagok felhasználásával, szigorú minőségellenőrzés és szabványok betartása mellett készül. Ha bármilyen problémát észlel a megvásárolt termékkel kapcsolatban, kérjük, vegye fel a kapcsolatot az ügyfélszolgálatnál a használati útmutató hátoldalán feltüntetett telefonszámon és e-mail címen.

A jótállás a vásárlás dátumától érvényes, amely a nyugtán vagy számlán szerepel, amelyet a jótállás érvényesítéséhez be kell mutatni.

A termékre vonatkozó jótállási időszak a vásárlás országában hatályos jogszabályoktól függően változik. További információkért kérjük, tekintse meg az Ön országában érvényes szabályozásokat.

⚠ A KÖVETKEZŐK NEM TARTOZNAK A GARANCIA HATÁLYÁBÓL

Bizonyos okok kizárásra kerülnek a jótállásból, például:

- ⊗ Szállítási nemmegfelelőség esetén a szállítmányozási vállalatot előzetesen értesíteni kell. 24 óra telt el a kézbesítés óta.
- ⊗ Rossz időjárás okozta törések vagy károk.
- ⊗ Nem megfelelő összeszerelés, helytelen használat és az ebből eredő következmények.

Ezenkívül a dobozon található QR-kód beolvasásával megtekintheti a három teljes listáját.

AZ ÖSSZESZERELÉSHEZ SZÜKSÉGES SZERSZÁMOK

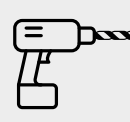





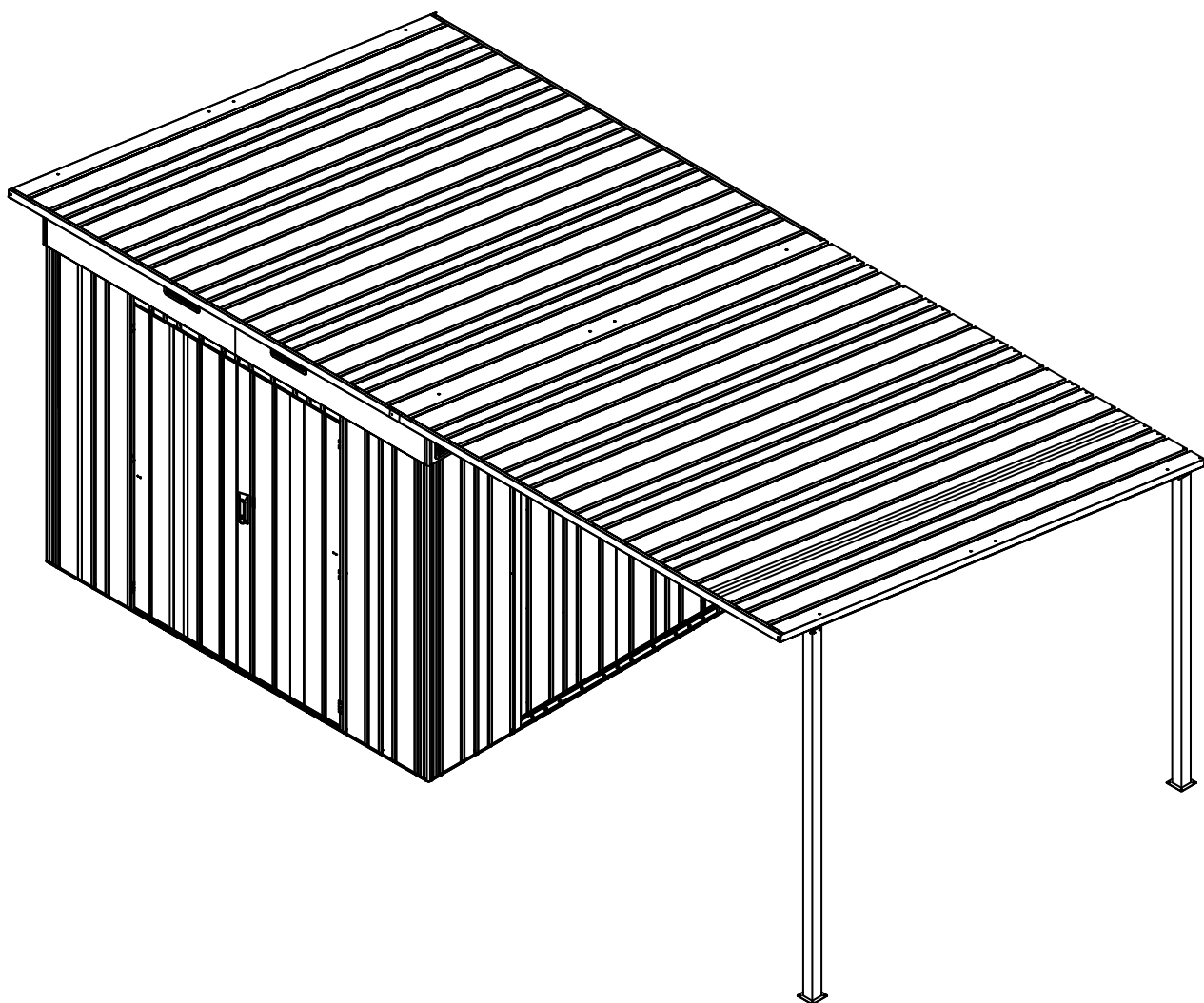







ASSEMBLY · MONTAJE · MONTAGEM · MONTAGE · ΣΥΝΑΡΜΟΛΟΓΗΣΗ
MONTAGGIO · MONTÁŽ · MONTAŽA · MONTERING · MONTAJ · MONTIMI
СБОРКА · MONTAŽ · ÖSSZESZERELÉS































 Máx. 60 Kg/m²  	Máx. 100 km/h  	<p> El techo debe mantenerse limpio de residuos, como hojas caídas o nieve. / The roof should be kept clean from debris, such as fallen leaves or snow. / Le toit doit être maintenu propre des débris, tels que les feuilles tombées ou la neige. / O telhado deve ser mantido limpo de detritos, como folhas caídas ou neve. / Das Dach sollte frei von Ablagerungen wie Laub oder Schnee gehalten werden. / Το ταβάνιο πρέπει να διατηρείται καθαρό από κατάλοιπα, όπως πτωχά φύλλα ή χιόνι. / Il tetto deve essere tenuto pulito da detriti, come foglie cadute o neve. / Streha mora ostati čista pred ostanki, kot so padlo listje ali sneg. / Strecha by mala zostat čistá od nečistôt, ako sú opadané listy alebo sneg. / Krov bi trebao ostati čist od otpada, kao što su opalo lišće ili snijeg. / Strecha musí byť čistá od nečistôt, jako je spadané listy nebo snih. </p>
--	--	--





MSP2505

PART	NO	QTY
	1H002	11
	1H021	2
	1G002	2
	1G022	2
	6B008	1
	6B009	1

PART	NO	QTY
	3F015	1
	3D024	1
	3F007	1
	3D023	1
	3F008	1
	3F016	1
	3F017	1



PART	NO	QTY
	D354	12
	D355	6
	D376	2
	D377	1
	D378	1
	D438	4
	H48	8
	H127	115
	H147	2
	H170	6
	H181	1
	A112	1
	S63	15
	M4X12	
	S74	550
	M4X8	
	M08	2
	M5	
	M11	8
	M6	
	M25	588
	M4	
	S75	36
	M4X10	
	J156	24
	Z40	24
	M5X40	
	Z41	2
	M4.2X9.5	
	S69	8

PART	NO	QTY
	D358	1
	D359	1
	Y1	1

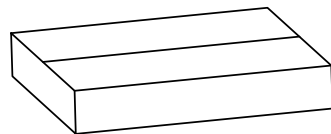
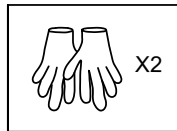
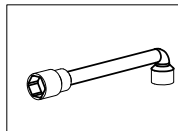
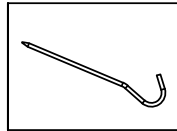
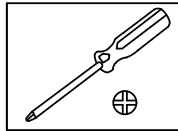
Tools Provided:



Box No. 1

PART	NO	QTY
	1H012	1
	1F005	10
	1F006	10



Box No. 2

MSP2505

	PART	NO	QTY		PART	NO	QTY		PART	NO	QTY	
1		2A006	3	6		4A037	2	7		2B002	1	
		2A004	1			4B001	2			2B002	1	
		2A005	1			4B001	2			2B002	1	
		4A005	2		6B011	1			2B011	1		
2		2P018	1		6B012	1	5			2C003	1	
		2P019	1		4B008	2				2C004	1	
		2R002	4		4B010	2	6			6B018	1	
		2R014	4	8		5F048		1	7		6B019	1
		3L011	1			5F056		1				
		3L012	1			5F057		1				
		3J006	2		5F059	1						
		3J007	2		5G058	1						
		3J011	2	9		5F058		1				
		3J019	1			5G047	1					
	3J020	1			5G056	1						
	3J020	1			5G057	1						
3		2H021	1		5G059	1	10		6B010	2		
		2N023	1		4C002	1			4C007	1		
		2N026	1		4C007	1						
		2P008	2	11		6B013	2					
		2P007	2			6B014	1					
4		4A022	1	12		6B015	1					
		4A016	1			6B016	1					
5		4A036	1			6B017	1					
		4A038	1			6B017	1					
		2A002	4			6B022	1					

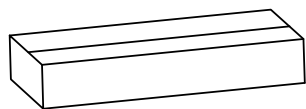

Box No. 3

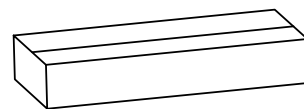

Box No. 4

PART	NO	QTY
	1G002	1
	4A005	1
	4A016	1
	H170	3
	D354	3
	S74 M4X8	4
	S75 M4X10	9
	M25 M4	13





LEFT DOOR · PUERTA IZQUIERDA · PORTA ESQUERDA · PORTE GAUCHE · LINKE TÜR · ΑΡΙΣΤΕΡΗ ΠΟΡΤΑ
· PORTA SINISTRA · LAVÉ DVERE · LIJEVA VRATA · LEVÉ DVERE · LEVA VRATA · VÄNSTER DÖRR · SOL KAPI ·
DERA E MAJTE · ЛЕВАЯ ДВЕРЬ · LEWE DRZWI · BAL AJTO

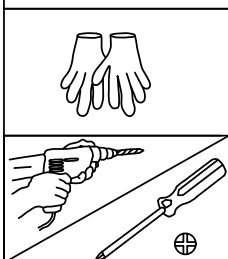
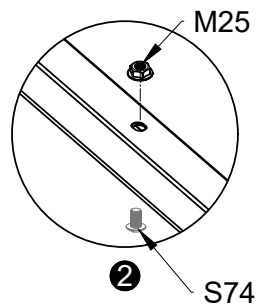
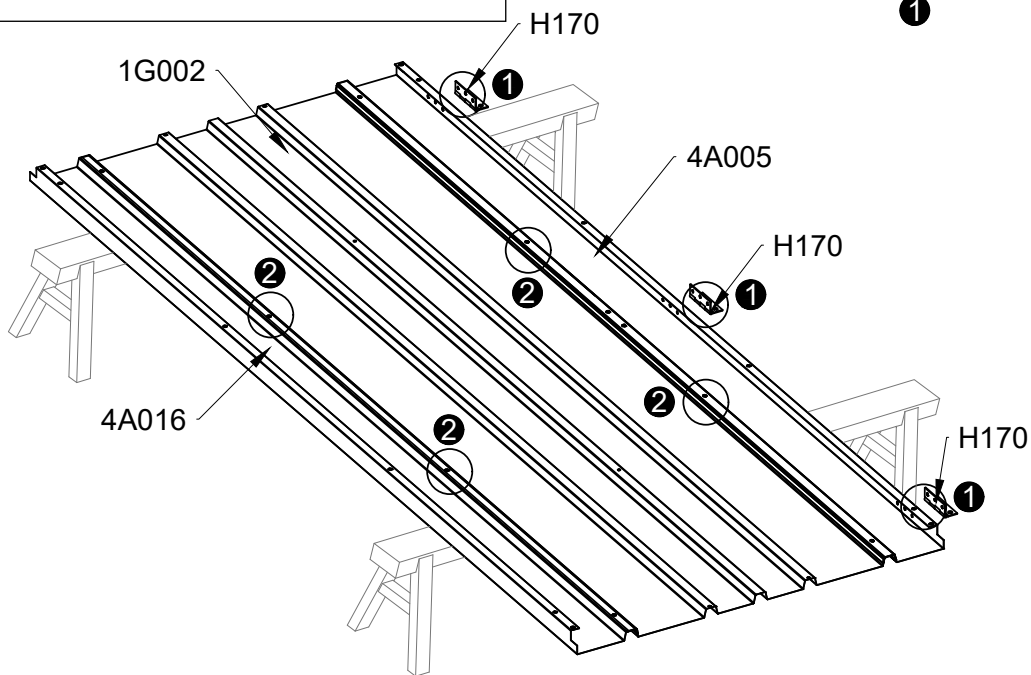
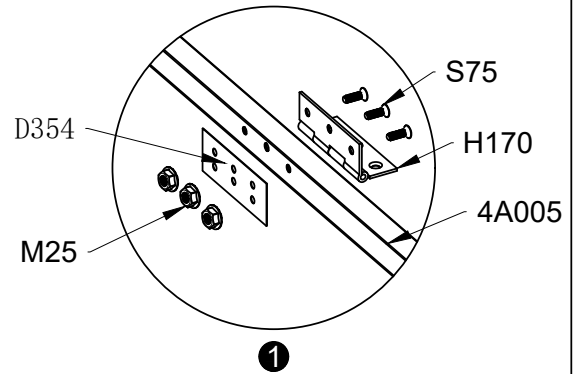

Lay down 4A016, 4A005 and 1G002 as below

LAY DOWN 4A016, 4A005 AND 1G002 AS BELOW · ESTABLEZCA 4A016, 4A005 Y 1G002 COMO SE INDICA A CONTINUACIÓN · ESTABELEÇA 4A016, 4A005 E 1G002 CONFORME ABAIXO · DÉFINIR 4A016, 4A005 ET 1G002 COMME SUIT · LEGEN SIE 4A016, 4A005 UND 1G002 WIE FOLGT FEST · ΚΑΘΟΡΙΣΤΕ ΤΑ 4A016, 4A005 ΚΑΙ 1G002 ΩΣ ΕΞΗΣ · STABILIRE 4A016, 4A005 E 1G002 COME SEGUE · USTANOVTE 4A016, 4A005 A 1G002 PODĽA NIŽŠIE UVEDENÉHO ZNENIA · POSTAVITE 4A016, 4A005 I 1G002 KAKO SLJEDI · UVEDTE 4A016, 4A005 A 1G002 NIŽE · DOLOČITE 4A016, 4A005 IN 1G002, KOT JE NAVEDENO SPODAJ · FASTSTÄLL 4A016, 4A005 OCH 1G002 ENLIGT NEDAN · 4A016, 4A005 VE 1G002'YI AŞAĞIDAKI GIBI DÜZENLEYİN · VENDOSNI 4A016, 4A005 DHE 1G002 SI MĚ POSHTE · УСТАНОВИТЕ 4A016, 4A005 И 1G002, КАК ПОКАЗАНО НИЖЕ · USTAL 4A016, 4A005 I 1G002 JAK PONIZEJ · A 4A016, 4A005 ES 1G002 PONTOKAT AZ ALÁBBIAK SZERINT HATÁROZZA MEG



PART	NO	QTY
	4B001	2
	H147	2
	M08	2
	M5	
	S74	4
	M4X8	



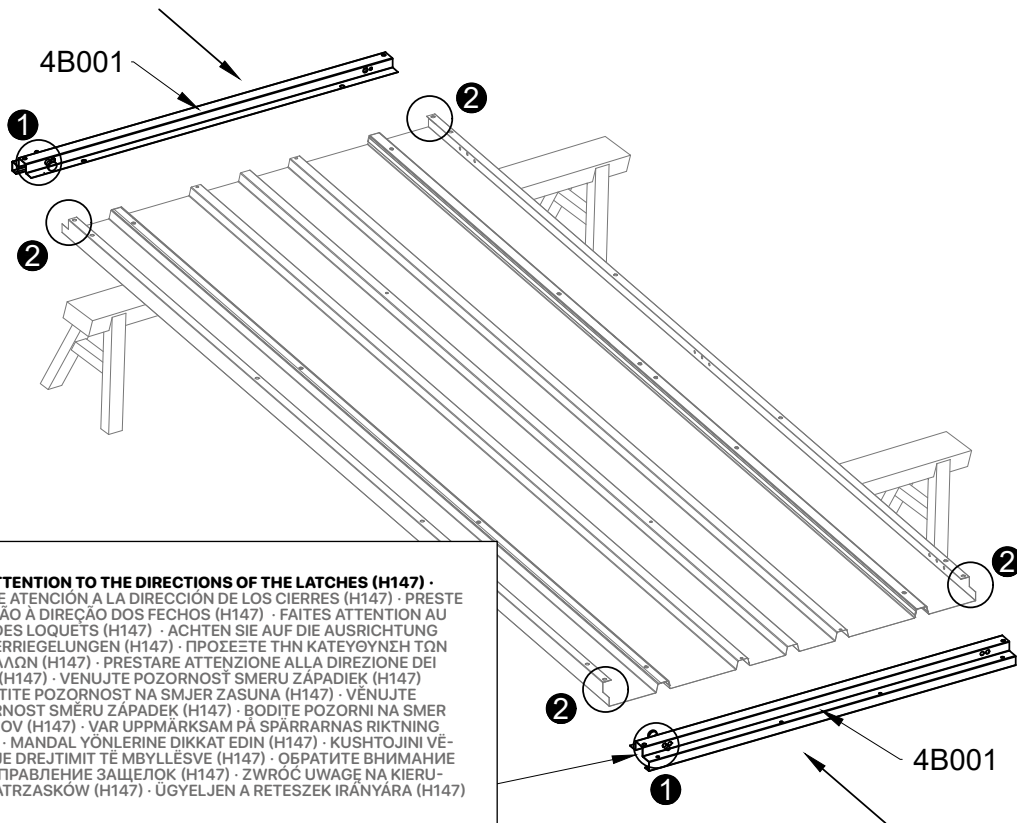
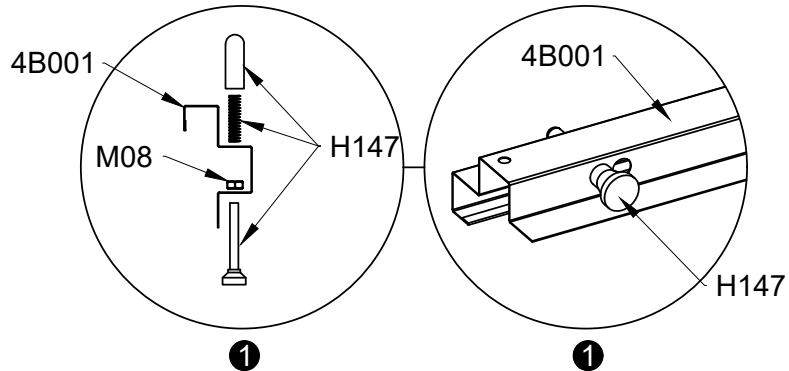

LEFT DOOR · PUERTA IZQUIERDA · PORTA ESQUERDA · PORTE GAUCHE · LINKE TÜR · ΑΡΙΣΤΕΡΗ ΠΟΡΤΑ · PORTA SINISTRA · LAVÉ DVĚŘE · LJEVA VRATA · LEVÉ DVĚŘE · LEVA VRATA · VÄNSTER DÖRR · SOL KAPI · DERA E MAJTE · ЛЕВАЯ ДВЕРЬ · LEWE DRZWI · BAL AJTO

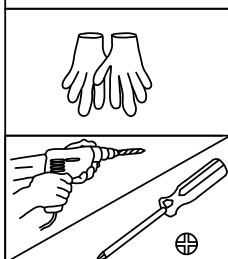
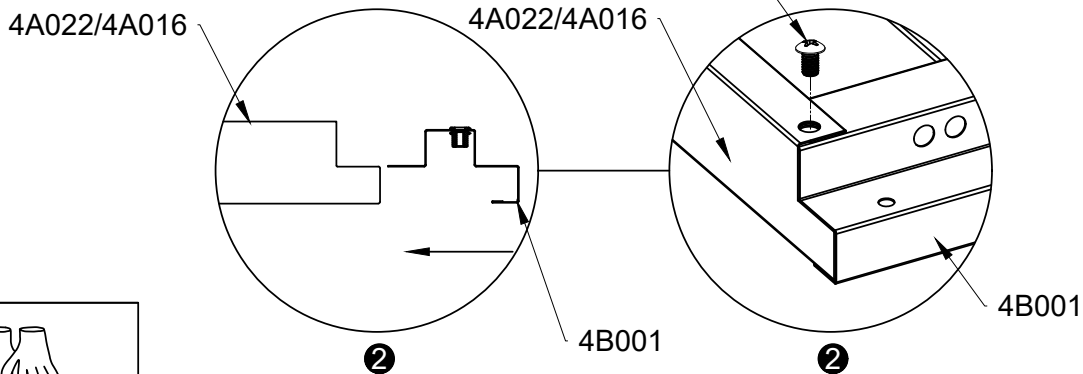

PAY ATTENTION TO THE DIRECTIONS OF THE LATCHES (H147) · PRESTE ATENCIÓN A LA DIRECCIÓN DE LOS CIERRES (H147) · PRESTE ATENÇÃO À DIREÇÃO DOS FECHOS (H147) · FAITES ATTENTION AU SENS DES LOQUETS (H147) · ACHTEN SIE AUF DIE AUSRICHTUNG DER VERRIEGELUNGEN (H147) · ΠΡΟΣΕΞΤΕ ΤΗΝ ΚΑΤΕΥΘΥΝΣΗ ΤΩΝ ΜΑΝΤΑΛΩΝ (H147) · PRESTARE ATTENZIONE ALLA DIREZIONE DEI FERMI (H147) · VENUJTE POZORNOST SMERU ZÁPADIEK (H147) · OBRATITE POZORNOST NA SMJER ZASUNA (H147) · VĚNUJTE POZORNOST SMĚRU ZÁPADEK (H147) · BODITE POZORNI NA SMER ZAPAHOV (H147) · VAR UPPMÄRKSAM PÅ SPÄRRARNAS RIKTNING (H147) · MANDAL YÖNLERINE DIKKAT EDIN (H147) · KUSHTOJINI VËMENDJE DREJTIMIT TË MBYLLËSVE (H147) · ОБРАТИТЕ ВНИМАНИЕ НА НАПРАВЛЕНИЕ ЗАЩЕЛОК (H147) · ZWRÓC UWAGĘ NA KIERUNEK ZATRZASKÓW (H147) · ÜGYELJEN A RETESZEK IRÁNYÁRA (H147)



PAY ATTENTION TO THE CONNECTION METHOD BETWEEN 4A022/4A016 AND 4B001 · PRESTE ATENCIÓN AL MÉTODO DE CONEXIÓN ENTRE 4A022/4A016 Y 4B001 · PRESTE ATENÇÃO AO MÉTODO DE CONEXÃO ENTRE 4A022/4A016 E 4B001 · FAITES ATTENTION À LA MÉTHODE DE CONNEXION ENTRE 4A022/4A016 ET 4B001 · ACHTEN SIE AUF DIE VERBINDUNGSMETHODE ZWISCHEN 4A022/4A016 UND 4B001 · ΠΡΟΣΕΞΤΕ ΤΗ ΜΕΘΟΔΟ ΣΥΝΔΕΣΗΣ ΜΕΤΑΞΥ 4A022/4A016 ΚΑΙ 4B001 · PRESTARE ATTENZIONE AL METODO DI CONNESSIONE TRA 4A022/4A016 E 4B001 · VENUJTE POZORNOST SPÔSOBU SPOJENIA MEDZI 4A022/4A016 A 4B001 · OBRATITE POZORNOST NA METODU SPAJANJA IZMEĐU 4A022/4A016 I 4B001 · VĚNUJTE POZORNOST ZPŮSOBU PROPOJENÍ MEZI 4A022/4A016 A 4B001 · BODITE POZORNI NA NAČIN POVEZAVE MED 4A022/4A016 IN 4B001 · VAR UPPMÄRKSAM PÅ ANSLUTNINGSMETODEN MELLAN 4A022/4A016 OCH 4B001 · 4A022/4A016 ILE 4B001 ARASINDAKI BAĞLANTI YÖNTEMİNE DIKKAT EDİN · KUSHTOJINI VËMENDJE METODËS SË LIDHJES MIDIS 4A022/4A016 DHE 4B001 · ОБРАТИТЕ ВНИМАНИЕ НА СПОСОБ СОЕДИНЕНИЯ МЕЖДУ 4A022/4A016 И 4B001 · ZWRÓC UWAGĘ NA METODĘ POŁĄCZENIA MIĘDZY 4A022/4A016 A 4B001 · ÜGYELJEN A 4A022/4A016 ÉS A 4B001 KÖZÖTTI CSATLAKOZÁSI MÓDRA





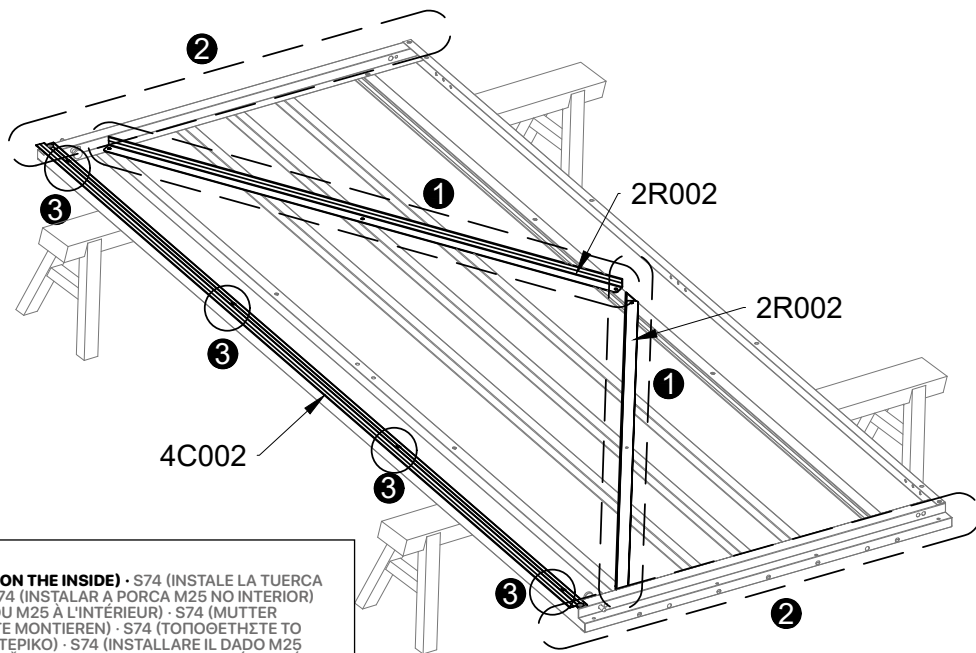
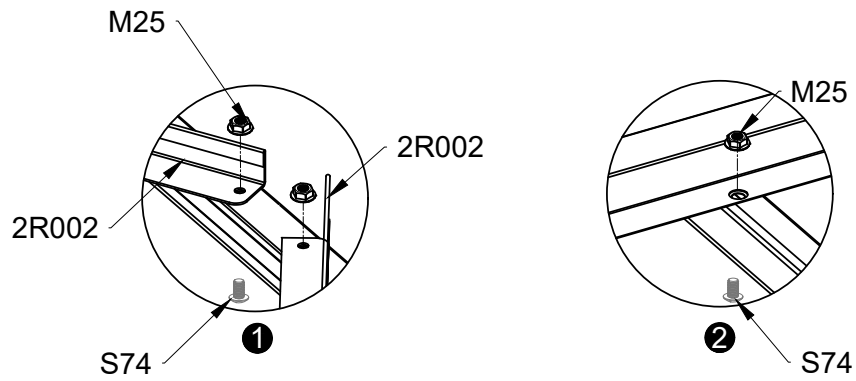

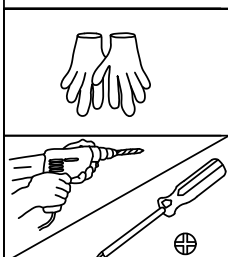
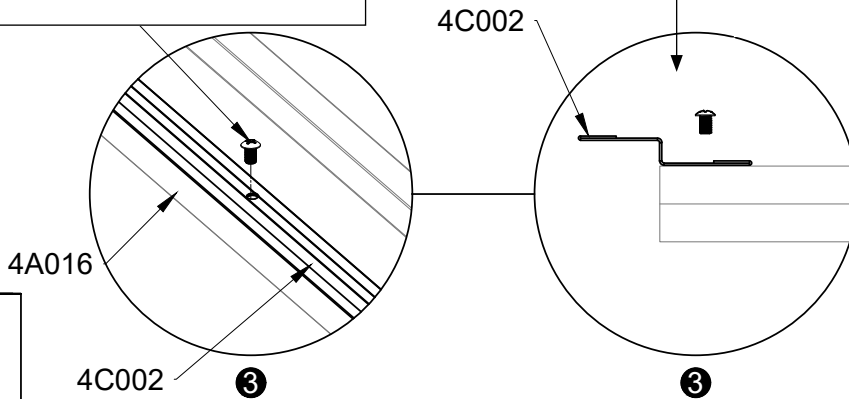

PART	NO	QTY
	4C002	1
	2R002	2
	S74 M4X8	16
	M25 M4	16

LEFT DOOR · PUERTA IZQUIERDA · PORTA ESQUERDA · PORTE GAUCHE · LINKE TÜR · ΑΡΙΣΤΕΡΗ ΠΟΡΤΑ · PORTA SINISTRA · L'AVÈ DVERE · LJEVA VRATA · LEVÉ DVERÈ · LEVA VRATA · VÄNSTER DÖRR · SOL KAPI · DERA E MAJTË · ЛЕВАЯ ДВЕРЬ · LEWE DRZWI · BAL AJTO





S74 (INSTALL NUT M25 ON THE INSIDE) · S74 (INSTALE LA TUERCA M25 EN EL INTERIOR) · S74 (INSTALAR A PORCA M25 NO INTERIOR) · S74 (INSTALLER L'ÉCROU M25 À L'INTÉRIEUR) · S74 (MUTTER M25 AUF DER INNENSEITE MONTIEREN) · S74 (ΤΟΠΟΘΕΤΗΣΤΕ ΤΟ ΠΑΞΙΜΑΔΙ Μ25 ΣΤΟ ΕΣΩΤΕΡΙΚΟ) · S74 (INSTALLARE IL DADO M25 ALL'INTERNO) · S74 (NAINŠTALUJTE MATICU M25 NA VNÚTORNÚ STRANU) · S74 (UGRADITE MATICU M25 S UNUTARNJE STRANE) · S74 (NAMONTUJTE MATICI M25 NA VNITRNÍ STRANU) · S74 (NAMESTITE MATICO M25 NA NOTRANJO STRAN) · S74 (INSTALLERA MUTTER M25 PÅ INSIDAN) · S74 (M25 SOMUNU IÇ TARAFI TAKIN) · S74 (INSTALONI DADON M25 NË PËJESËN E BRENDSHMË) · S74 (УСТАНОВИТЕ ГАЙКУ М25 НА ВНУТРЕННЮЮ СТОРОНУ) · S74 (ZAMONTUJ NAKRETKË M25 OD WEWNÄTRZ) · S74 (SZERELJE FEL AZ M25-ÖS ANYÁT A BÉLSŐ OLDALRA)

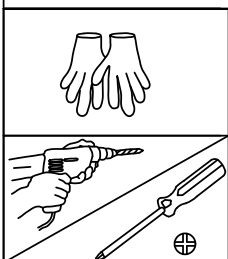
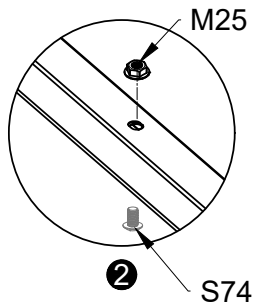
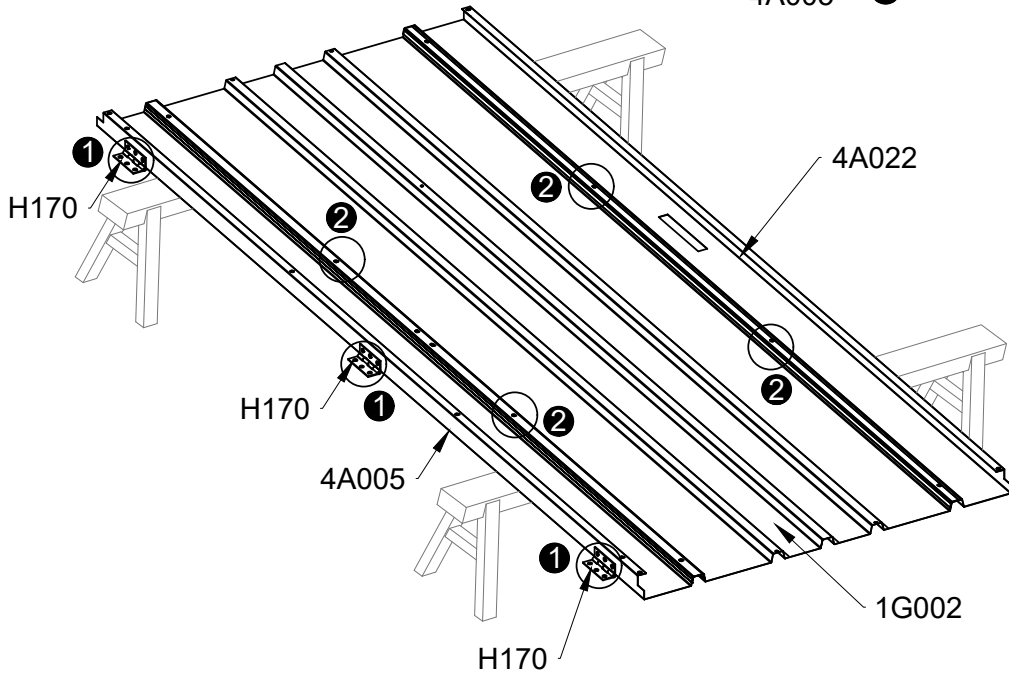
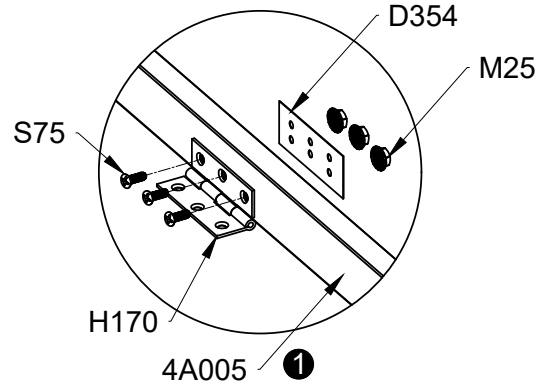
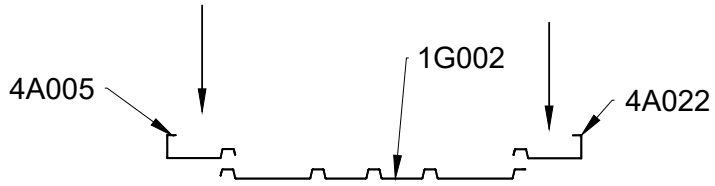

PART	NO	QTY
	1G002	1
	4A022	1
	4A005	1
	H170	3
	D354	3
	S74 M4X8	4
	S75 M4X10	9
	M25 M4	13

RIGHT DOOR · PUERTA DERECHA · PORTA DIREITA · PORTE DROITE · RECHTE TÜR · ΔΕΞΙΑ ΠΟΡΤΑ · PORTA DESTRA · PRÁVÉ DVERĚ · DESNA VRATA · PRÁVÉ DVERĚ · DESNA VRATA · HÖGER DÖRR · SAĞ KAPI · DERA E DJATHË · ПРАВАЯ ДВЕРЬ · PRAWIE DRZWI · JOBB AJTÓ



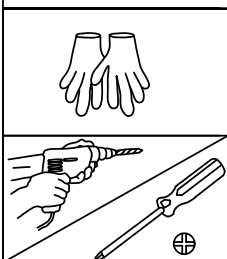
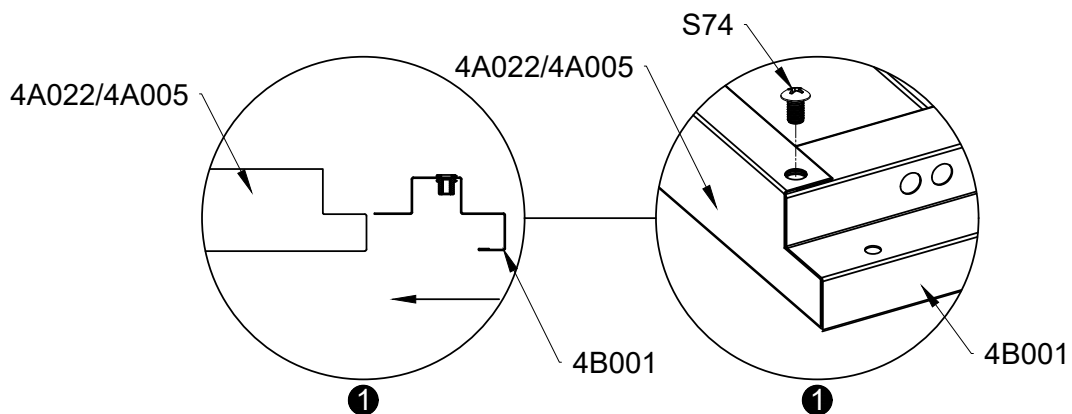
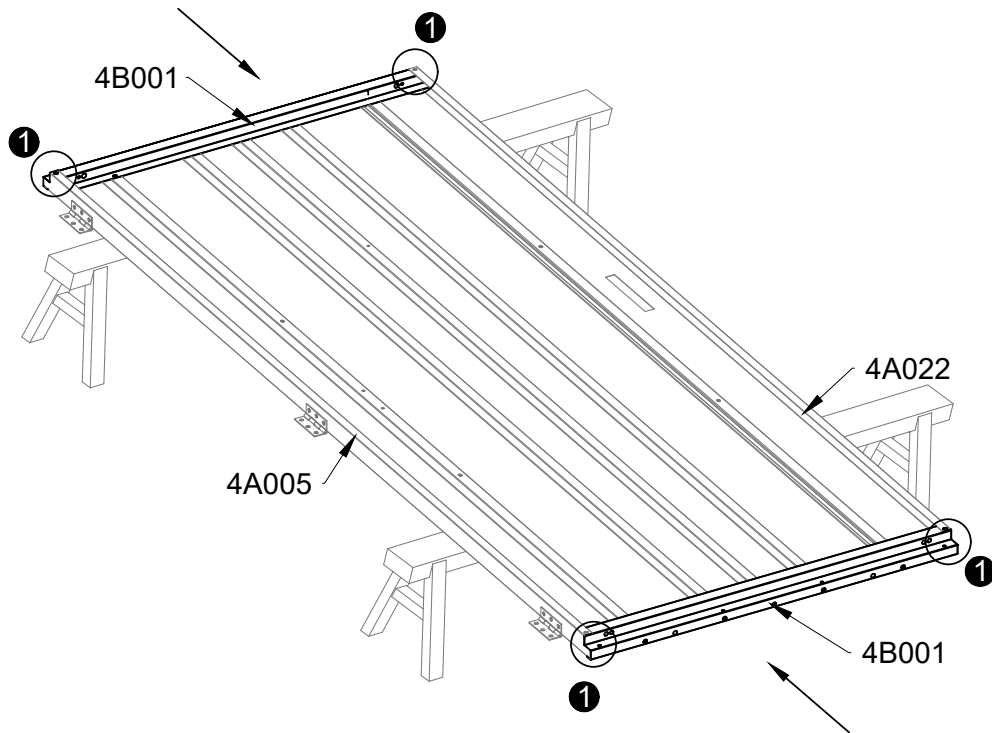

PART	NO	QTY
	4B001	2
	S74 M4X8	4

RIGHT DOOR · PUERTA DERECHA · PORTA DIREITA · PORTE DROITE · RECHTE TÜR · ΔΕΞΙΑ ΠΟΡΤΑ · PORTA DESTRA · PRÁVÉ DVERĚ · DESNA VRATA · PRÁVÉ DVERĚ · DESNA VRATA · HÖGER DÖRR · SAĞ KAPI · DERA E DJATHË · ПРАВАЯ ДВЕРЬ · PRAWIE DRZWI · JOBB AJTÓ





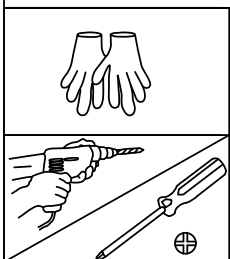
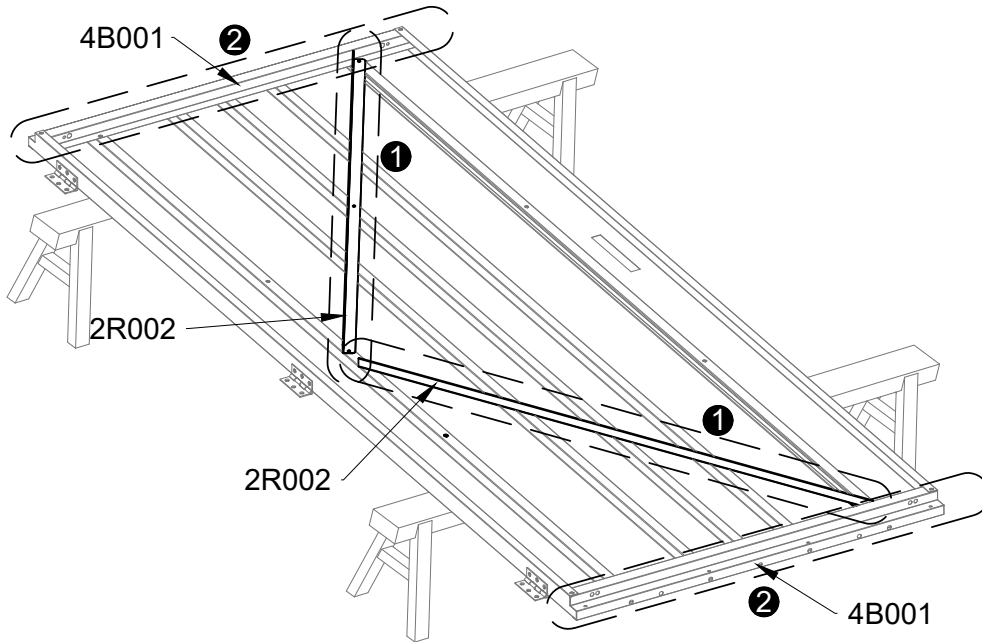
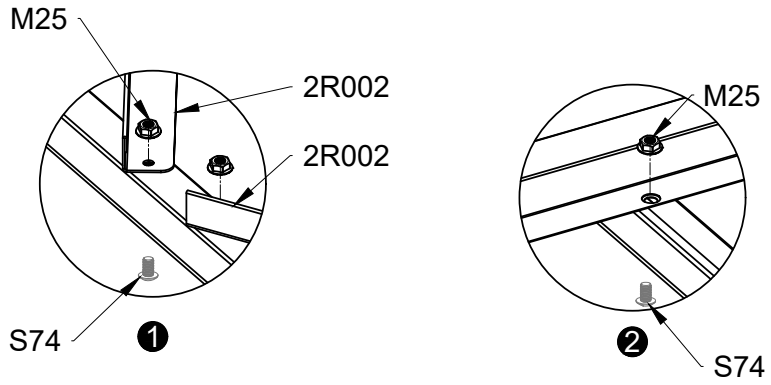

PAY ATTENTION TO THE CONNECTION METHOD BETWEEN 4A022/4A005 AND 4B001 · PRESTE ATENCIÓN AL MÉTODO DE CONEXIÓN ENTRE 4A022/4A005 Y 4B001 · PRESTE ATENÇÃO AO MÉTODO DE CONEXÃO ENTRE 4A022/4A005 E 4B001 · FAITES ATTENTION À LA MÉTHODE DE CONNEXION ENTRE 4A022/4A005 ET 4B001 · ACHTEN SIE AUF DIE VERBINDUNGS-METHODE ZWISCHEN 4A022/4A005 UND 4B001 · ΠΡΟΣΕΞΤΕ ΤΗ ΜΕΘΟΔΟ ΣΥΝΔΕΣΗΣ ΜΕΤΑΞΥ 4A022/4A005 ΚΑΙ 4B001 · PRESTARE ATTENZIONE AL METODO DI CONNESSIONE TRA 4A022/4A005 E 4B001 · VENUJTE POZORNOST SPŮSOBU SPOJENIA MEDZI 4A022/4A005 A 4B001 · OBRATITE POZORNOST NA METODU SPAJANJA IZMEĐU 4A022/4A005 I 4B001 · VENUJTE POZORNOST ZPŮSOBU PROPOJENÍ MEZI 4A022/4A005 A 4B001 · BODITE POZORNI NA NAČIN POVEZAVE MED 4A022/4A005 IN 4B001 · VAR UPPMÄRKSAM PÅ ANSLUTNINGSMETODEN MELLAN 4A022/4A005 OCH 4B001 · 4A022/4A005 ILE 4B001 ARASINDAKI BAĞLANTI YÖNTEMINİ DİKKAT EDİN · KUSHTOJINI VËMENDJE METODËS SË LIDHJES MIDIS 4A022/4A005 DHE 4B001 · ОБРАТИТЕ ВНИМАНИЕ НА СПОСОБ СОЕДИНЕНИЯ МЕЖДУ 4A022/4A005 И 4B001 · ZWRŒC UWAGË NA METODË POŁĄCZENIA MIËDZY 4A022/4A005 A 4B001 · ÜGYELJEN A 4A022/4A005 ÉS A 4B001 KÖZÖTTI CSATLAKOZÁSI MÓDRA

PART	NO	QTY
	2R002	2
	S74 M4X8	12
	M25 M4	12

RIGHT DOOR · PUERTA DERECHA · PORTA DIREITA · PORTE DROITE · RECHTE TÜR · ΔΕΞΙΑ ΠΟΡΤΑ · PORTA DESTRA · PRÁVÉ DVERĚ · DESNA VRATA · PRÁVÉ DVERĚ · DESNA VRATA · HÖGER DÖRR · SAĞ KAPI · DERA E DJATHË · ПРАВАЯ ДВЕРЬ · PRAWO DRZWI · JOBB AJTÓ









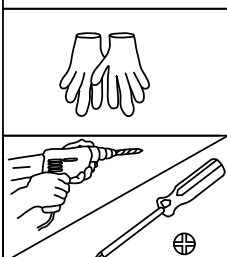
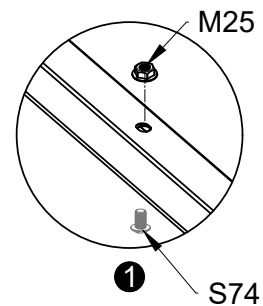
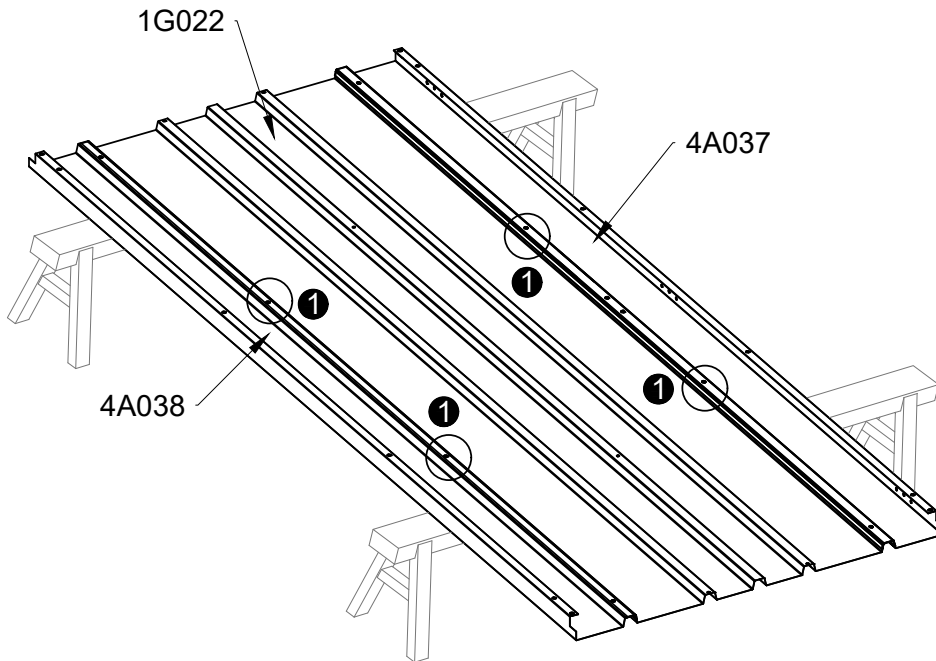

PART	NO	QTY
	1G022	1
	4A037	1
	4A038	1
	S74	4
	M4X8	
	M25	4
	M4	

LEFT DOOR · PUERTA IZQUIERDA · PORTA ESQUERDA · PORTE GAUCHE · LINKE TÜR · ΑΡΙΣΤΕΡΗ ΠΟΡΤΑ · PORTA SINISTRA · L'AVÉ DVERE · LJEVA VRATA · LEVÉ DVERĚ · LEVA VRATA · VÄNSTER DÖRR · SOL KAPİ · DERA E MAJTË · ЛЕВАЯ ДВЕРЬ · LEWE DRZWI · BAL AJTO



LAY DOWN 4A038, 4A037 AND 1G022 AS BELOW · COLOQUE 4A038, 4A037 Y 1G022 COMO SE INDICA ABAJO · COLOQUE 4A038, 4A037 E 1G022 COMO ABAIXO · POSEZ 4A038, 4A037 ET 1G022 COMME CI-DESSOUS · LEGEN SIE 4A038, 4A037 UND 1G022 WIE UNTEN AB · ΤΟΠΟΘΕΤΗΣΤΕ ΤΑ 4A038, 4A037 ΚΑΙ 1G022 ΟΠΩΣ ΠΑΡΑΚΑΤΩ · APPOGGIARE 4A038, 4A037 E 1G022 COME SOTTO · POŁOŻTE 4A038, 4A037 A 1G022 PODŁA OBRÁZKA NIŻŠIE · POŁOŻITE 4A038, 4A037 I 1G022 KAKO JE PRIKAZANO DOLJE · POŁOŻTE 4A038, 4A037 A 1G022 PODLE NIŽE UVEDENÉHO · POŁOŻITE 4A038, 4A037 IN 1G022, KOT JE PRIKAZANO SPODAJ · LÄGG NER 4A038, 4A037 OCH 1G022 ENLIGT NEDAN · 4A038, 4A037 VE 1G022 PARÇALARINI AŞAĞIDA GÖSTERİLDİĞİ GİBİ YERLEŞTİRİN · VENDOSNI 4A038, 4A037 DHE 1G022 SI MË POSHTË · ПОЛОЖИТЕ 4A038, 4A037 И 1G022, КАК ПОКАЗАНО НИЖЕ · POŁOŻ 4A038, 4A037 I 1G022 ZGODNIE Z PONIŻSZYM OPISEM · FEKTESSE LE A 4A038-AT, 4A037-ET ÉS AZ 1G022-T AZ ALÁBBIAK SZERINT





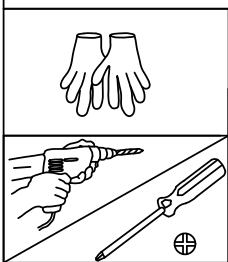
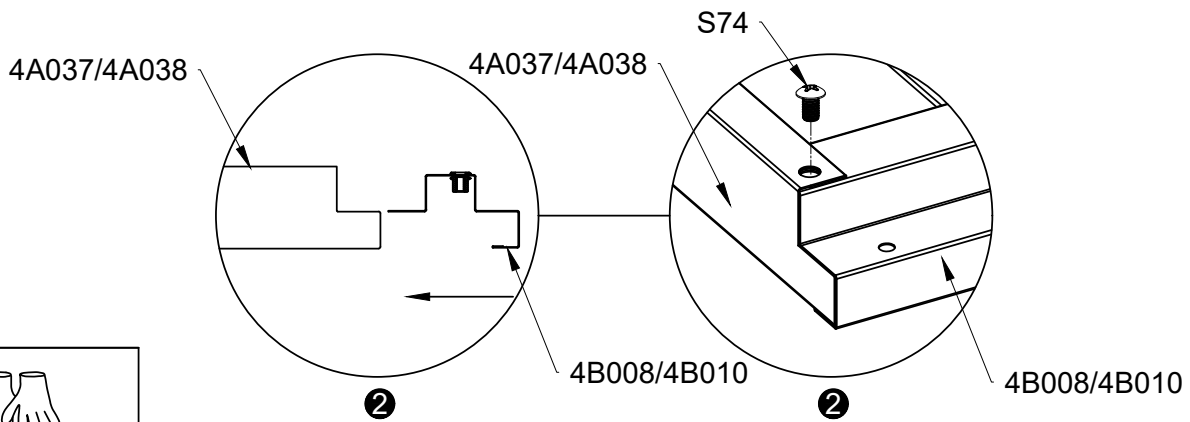
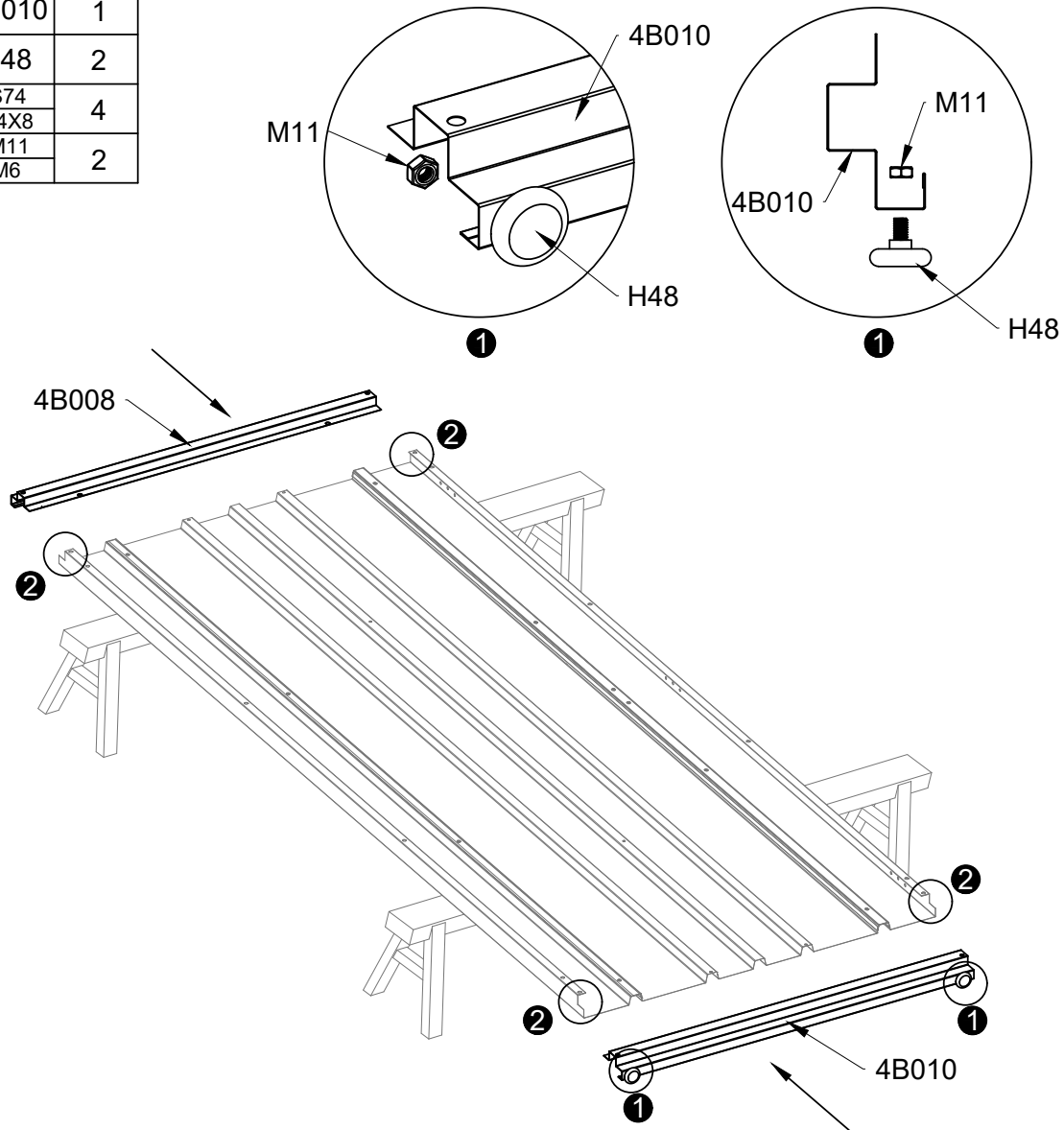

PART	NO	QTY
	4B008	1
	4B010	1
	H48	2
	S74	4
	M4X8	
	M11	2
	M6	

LEFT DOOR · PUERTA IZQUIERDA · PORTA ESQUERDA · PORTE GAUCHE · LINKE TÜR · ΑΡΙΣΤΕΡΗ ΠΟΡΤΑ · PORTA SINISTRA · L'AVÉ DVERE · LIJEVA VRATA · LEVÉ DVERĚ · LEVA VRATA · VÄNSTER DÖRR · SOL KAPI · DERA E MAJTE · ЛЕВАЯ ДВЕРЬ · LEWE DRZWI · BAL AJTO



PAY ATTENTION TO THE CONNECTION METHOD BETWEEN 4A037/4A038 AND 4B008/4B010 · PRESTE ATENCIÓN AL MÉTODO DE CONEXIÓN ENTRE 4A037/4A038 Y 4B008/4B010 · PRESTE ATENÇÃO AO MÉTODO DE CONEXÃO ENTRE 4A037/4A038 E 4B008/4B010 · FAITES ATTENTION À LA MÉTHODE DE CONNEXION ENTRE 4A037/4A038 ET 4B008/4B010 · ACHTEN SIE AUF DIE VERBINDUNGSMETHODE ZWISCHEN 4A037/4A038 UND 4B008/4B010 · ΠΡΟΣΕΞΤΕ ΤΗ ΜΕΘΟΔΟ ΣΥΝΔΕΣΗΣ ΜΕΤΑΞΥ 4A037/4A038 ΚΑΙ 4B008/4B010 · PRESTARE ATTENZIONE AL METODO DI CONNESSIONE TRA 4A037/4A038 E 4B008/4B010 · VENUJTE POZORNOST SPOSOBU SPOJENIA MEDZI 4A037/4A038 A 4B008/4B010 · OBRATITE POZORNOST NA METODU SPAJANJA IZMEDU 4A037/4A038 I 4B008/4B010 · VĚNUJTE POZORNOST ZPŮSOBU PROPOJENÍ MEZI 4A037/4A038 A 4B008/4B010 · BODITE POZORNÍ NA NAČIN POVEZAVE MED 4A037/4A038 IN 4B008/4B010 · VAR UPPMÄRKSAM PÅ ANSLUTNINGSMETODEN MELLAN 4A037/4A038 OCH 4B008/4B010 · 4A037/4A038 ILE 4B008/4B010 ARASINDAKI BAĞLANTI YÖNTEMİNE DİKKAT EDİN · KUSHTOJINI VĚMENDJE METODĚS SĚ LIDHJES MIDIS 4A037/4A038 DHE 4B008/4B010 · OBRATITE VNIΜΑΝΗE HA CΠOCOC COEΔHHEHHA MEJDY 4A037/4A038 I 4B008/4B010 · ZWRÓC UWAGĘ NA METODĘ POŁĄCZENIA MIĘDZY 4A037/4A038 A 4B008/4B010 · ÜGYELJEN A 4A037/4A038 ES A 4B008/4B010 KÖZÖTTI CSATLAKOZÁSI MÓDRA



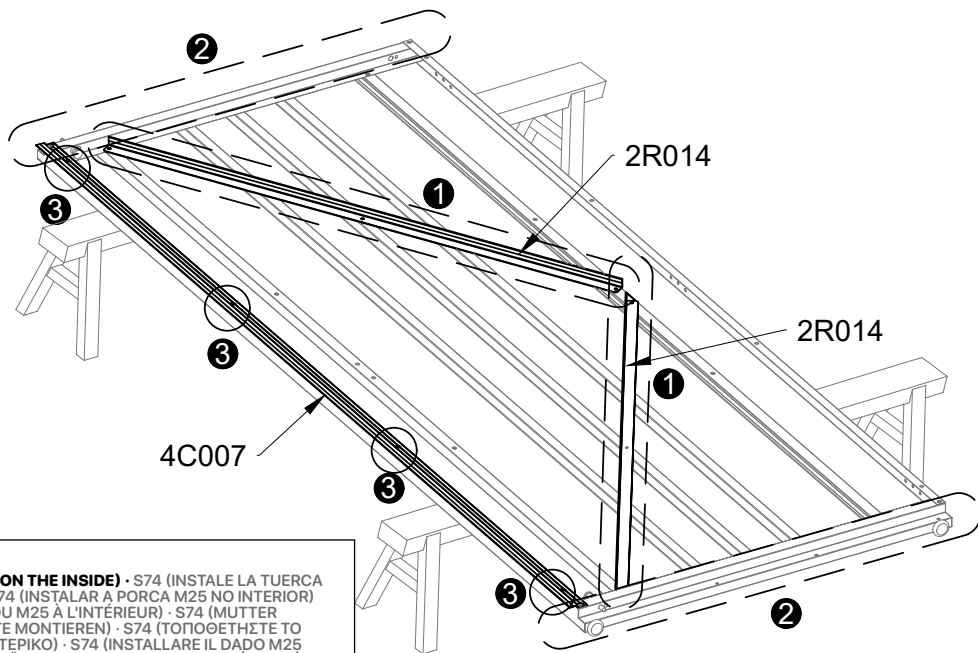
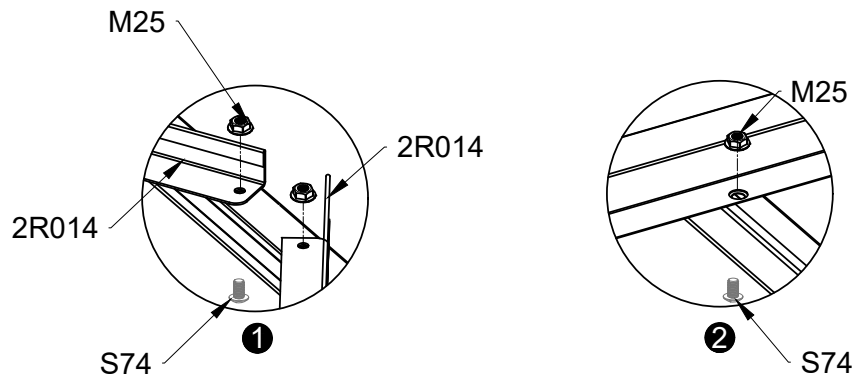

PART	NO	QTY
	4C007	1
	2R014	2
	S74 M4X8	16
	M25 M4	16

LEFT DOOR · PUERTA IZQUIERDA · PORTA ESQUERDA · PORTE GAUCHE · LINKE TÜR · ΑΡΙΣΤΕΡΗ ΠΟΡΤΑ
· PORTA SINISTRA · L'AVÉ DVERE · LJEVA VRATA · LEVÉ DVERE · LEVA VRATA · VÄNSTER DÖRR · SOL KAPI ·
DERA E MAJTË · ЛЕВАЯ ДВЕРЬ · LEWE DRZWI · BAL AJTO

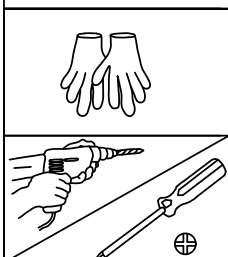
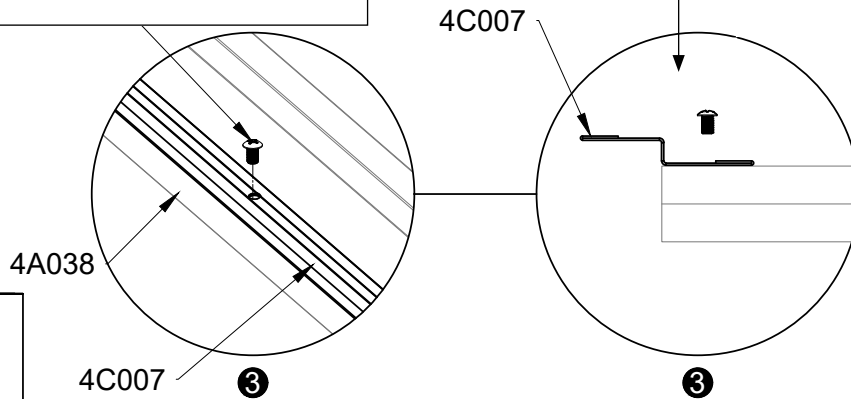







S74 (INSTALL NUT M25 ON THE INSIDE) · S74 (INSTALE LA TUERCA M25 EN EL INTERIOR) · S74 (INSTALAR A PORCA M25 NO INTERIOR) · S74 (INSTALLER L'ÉCROU M25 À L'INTÉRIEUR) · S74 (MUTTER M25 AUF DER INNENSEITE MONTIEREN) · S74 (ΤΟΠΟΘΕΤΗΣΤΕ ΤΟ ΠΑΞΙΜΑΔΙ Μ25 ΣΤΟ ΕΣΩΤΕΡΙΚΟ) · S74 (INSTALLARE IL DADO M25 ALL'INTERNO) · S74 (NAINŠTALUJTE MATICU M25 NA VNÚTORNÚ STRANU) · S74 (UGRADITE MATICU M25 S UNUTARNJE STRANE) · S74 (NAMONTUJTE MATICI M25 NA VNITRNI STRANU) · S74 (NAMESTITE MATICO M25 NA NOTRANJO STRAN) · S74 (INSTALLERA MUTTER M25 PÅ INSIDAN) · S74 (M25 SOMUNU IÇ TARAFI TAKIN) · S74 (INSTALONI DADON M25 NË PËJESËN E BRENDSHME) · S74 (УСТАНОВИТЕ ГАЙКУ М25 НА ВНУТРЕННЮЮ СТОРОНУ) · S74 (ZAMONTUJ NAKRÛTKË M25 OD WEWNÄTRZ) · S74 (SZERELJE FEL AZ M25-ÖS ANYÁT A BÉLSŐ OLDALRA)

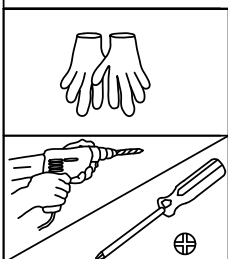
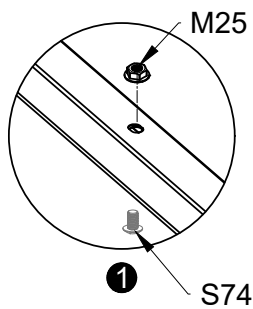
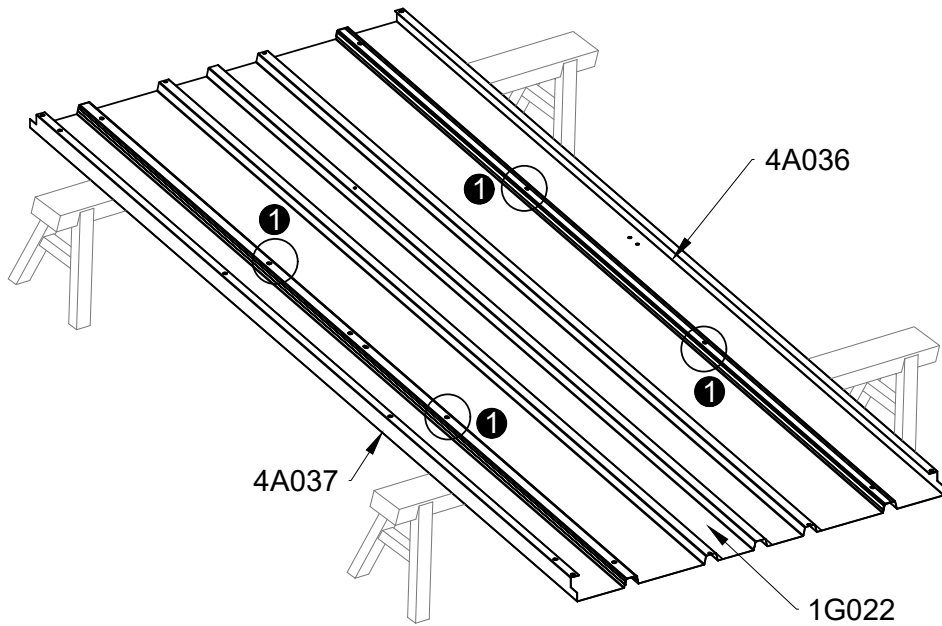
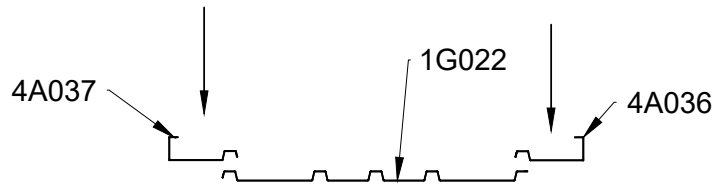

PART	NO	QTY
	1G022	1
	4A036	1
	4A037	1
	S74 M4X8	4
	M25 M4	4

RIGHT DOOR · PUERTA DERECHA · PORTA DIREITA · PORTE DROITE · RECHTE TÜR · ΔΕΞΙΑ ΠΟΡΤΑ · PORTA DESTRA · PRÁVÉ DVERE · DESNA VRATA · PRÁVÉ DVERĚ · DESNA VRATA · HÖGER DÖRR · SAĞ KAPI · DERA E DJATHË · ПРАВАЯ ДВЕРЬ · PRAWIE DRZWI · JOBB AJTÓ





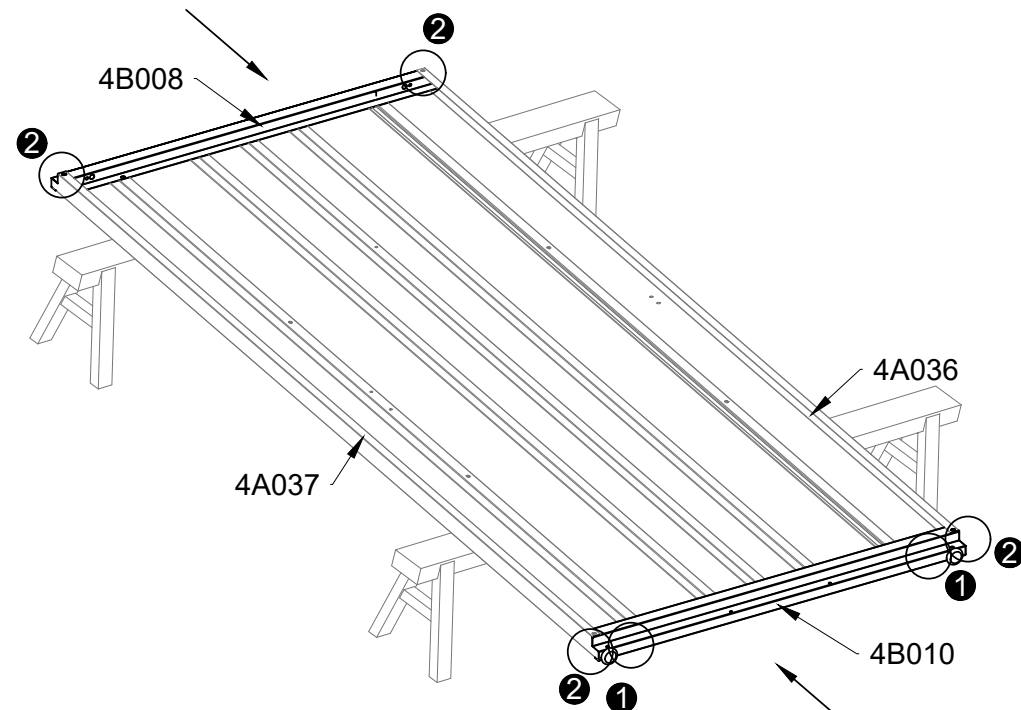
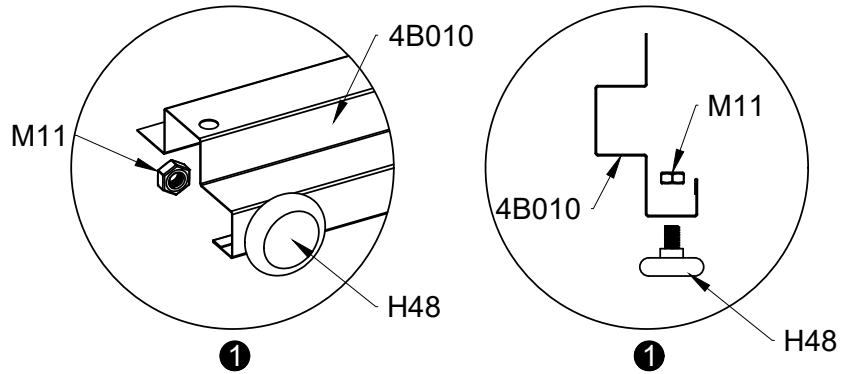

PART	NO	QTY
	4B008	1
	4B010	1
	H48	2
	S74 M4X8	4
	M11 M6	2

RIGHT DOOR · PUERTA DERECHA · PORTA DIREITA · PORTE DROITE · RECHTE TÜR · ΔΕΞΙΑ ΠΟΡΤΑ · PORTA DESTRA · PRÁVÉ DVĚŘE · DESNA VRATA · PRÁVÉ DVĚŘE · DESNA VRATA · HÖGER DÖRR · SAĞ KAPI · DERA E DJATHTË · ПРАВАЯ ДВЕРЬ · PRAWO DRZWI · JOBB AJTÓ

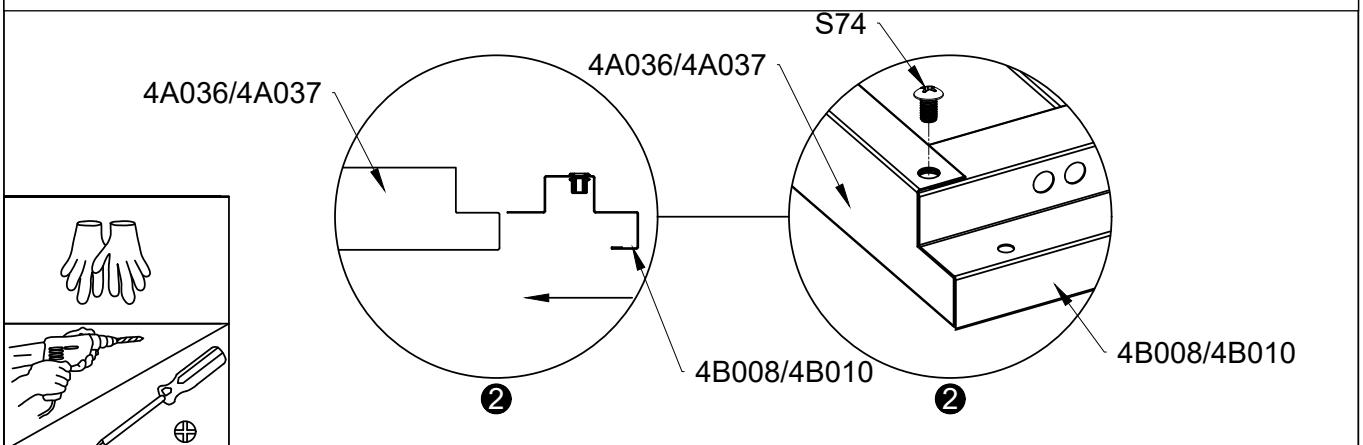

PAY ATTENTION TO THE CONNECTION METHOD BETWEEN 4A036/4A037 AND 4B008/4B010 · PRESTE ATENCIÓN AL MÉTODO DE CONEXIÓN ENTRE 4A036/4A037 Y 4B008/4B010 · PRESTE ATENÇÃO AO MÉTODO DE CONEXÃO ENTRE 4A036/4A037 E 4B008/4B010 · FAITES ATTENTION A LA METHODE DE CONNEXION ENTRE 4A036/4A037 ET 4B008/4B010 · ACHTEN SIE AUF DIE VERBINDUNGSMETHODE ZWISCHEN 4A036/4A037 UND 4B008/4B010 · ΠΡΟΣΕΞΤΕ ΤΗ ΜΕΘΟΔΟ ΣΥΝΔΕΣΗΣ ΜΕΤΑΞΥ 4A036/4A037 ΚΑΙ 4B008/4B010 · PRESTARE ATTENZIONE AL METODO DI CONNESSIONE TRA 4A036/4A037 E 4B008/4B010 · VENUJTE POZORNOST SPOSOBU SPOJENIA MEDZI 4A036/4A037 A 4B008/4B010 · OBRATITE POZORNOST NA METODU SPAJANJA IZMEĐU 4A036/4A037 I 4B008/4B010 · VENUJTE POZORNOST ZPUSOBU PROPOJENI MEZI 4A036/4A037 A 4B008/4B010 · BODITE POZORNI NA NACIN POVEZAVE MED 4A036/4A037 IN 4B008/4B010 · VAR UPPMARKSAM PÅ ANSLUTNINGSMETODEN MELLAN 4A036/4A037 OCH 4B008/4B010 · 4A036/4A037 ILE 4B008/4B010 ARASINDAKI BAGLANTI YONTEMINE DIKKAT EDIN · KUSHTO JINI VEMENDJE METODES SE LIDHJES MIDIS 4A036/4A037 DHE 4B008/4B010 · OBRATITE VНИМАНИЕ НА СПОСОБ СОЕДИНЕНИЯ МЕЖДУ 4A036/4A037 И 4B008/4B010 · ZWROC UWAGĘ NA METODĘ POŁĄCZENIA MIĘDZY 4A036/4A037 A 4B008/4B010 · UGYELJEN A 4A036/4A037 ES A 4B008/4B010 KOZOTTI CSATLAKOZÁSI MODRA



PART	NO	QTY
	2R014	2
	S74 M4X8	12
	M25 M4	12

RIGHT DOOR · PUERTA DERECHA · PORTA DIREITA · PORTE DROITE · RECHTE TÜR · ΔΕΞΙΑ ΠΟΡΤΑ · PORTA DESTRA · PRÁVÉ DVERĚ · DESNA VRATA · PRÁVÉ DVERĚ · DESNA VRATA · HÖGER DÖRR · SAĞ KAPI · DERA E DJATHË · ПРАВАЯ ДВЕРЬ · PRAWO DRZWI · JOBB AJTÓ

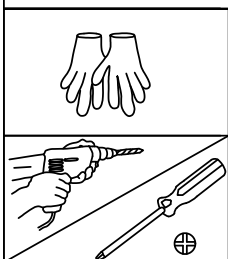
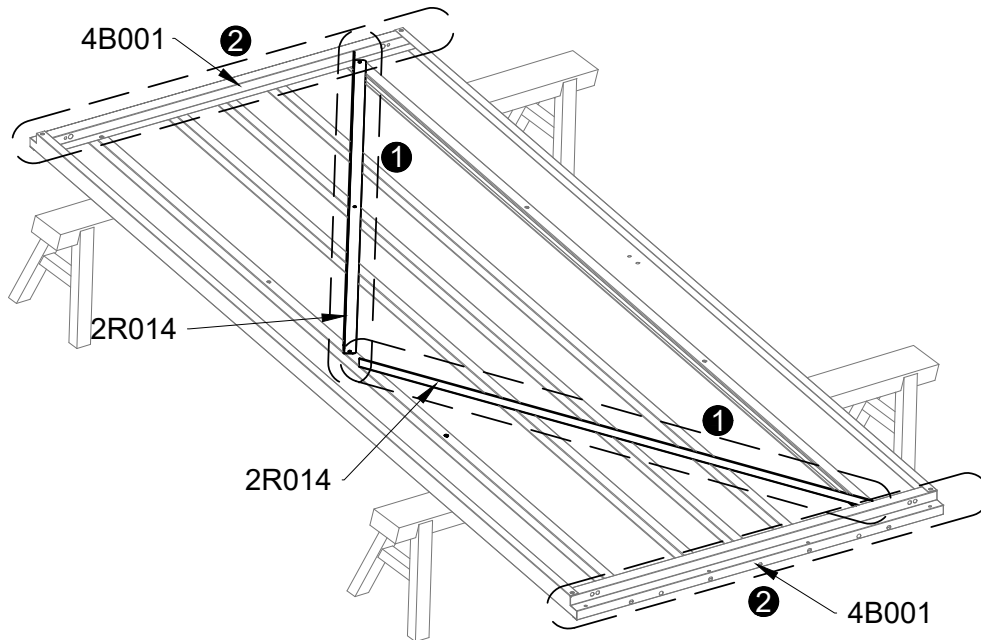
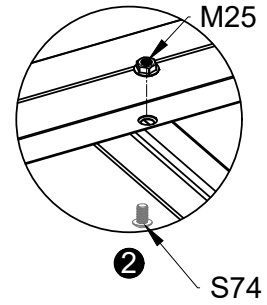
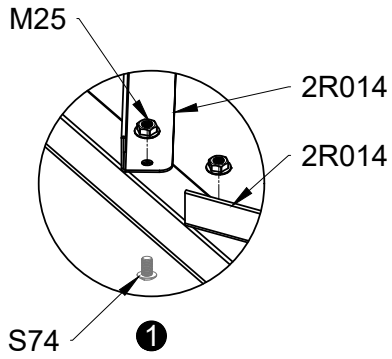



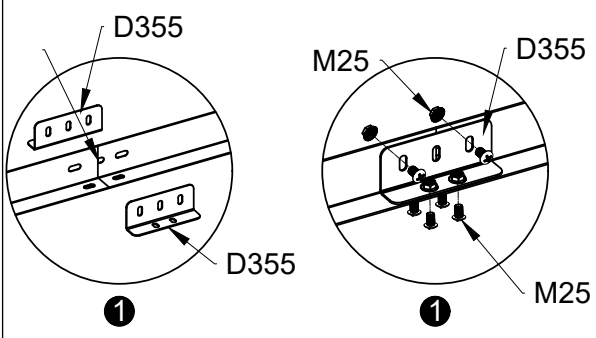

PART	NO	QTY
	2A002	4
	2A004	1
	2A005	1
	2A006	3
	D355	6
	D438	4
	S74 M4X8	24
	M25 M4	24

ATTENTION: NOTCH ON THE 2A004, 2A005, 2A006 · ATENCIÓN: MUESCA EN LOS 2A004, 2A005, 2A006 · ATENÇÃO: ENTALHE NO 2A004, 2A005, 2A006 · ATTENTION : ENCOCHE SUR LES 2A004, 2A005, 2A006 · ACHTUNG: KERBE AN 2A004, 2A005, 2A006 · ΠΡΟΣΟΧΗ: ΕΓΚΟΠΗ ΣΤΑ 2A004, 2A005, 2A006 · ATTENZIONE: TACCA SU 2A004, 2A005, 2A006 · POZOR: ZÁREZ NA 2A004, 2A005, 2A006 · POZOR: UREZ NA 2A004, 2A005, 2A006 · POZOR: ZÁREZ NA 2A004, 2A005, 2A006 · OBSERVERA: JACK PÁ 2A004, 2A005, 2A006 · DIKKAT: 2A004, 2A005, 2A006 ÜZERİNDEKİ ÇENTİK · КУЖДЕС: ДНЕМБЕЗИМИ НЭ 2A004, 2A005, 2A006 · ВНИМАНИЕ: ВЫЕМКА НА 2A004, 2A005, 2A006 · UWAGA: WYCIECIE NA 2A004, 2A005, 2A006 · FIGYELEM: HORONY A 2A004, 2A005, 2A006 ELEMENEN

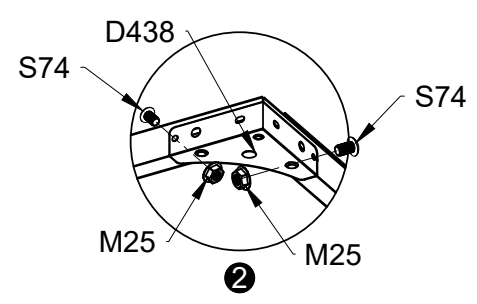
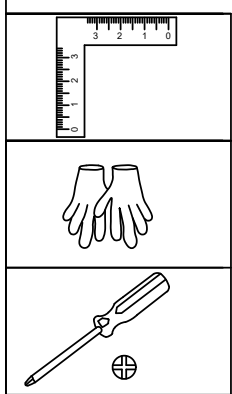
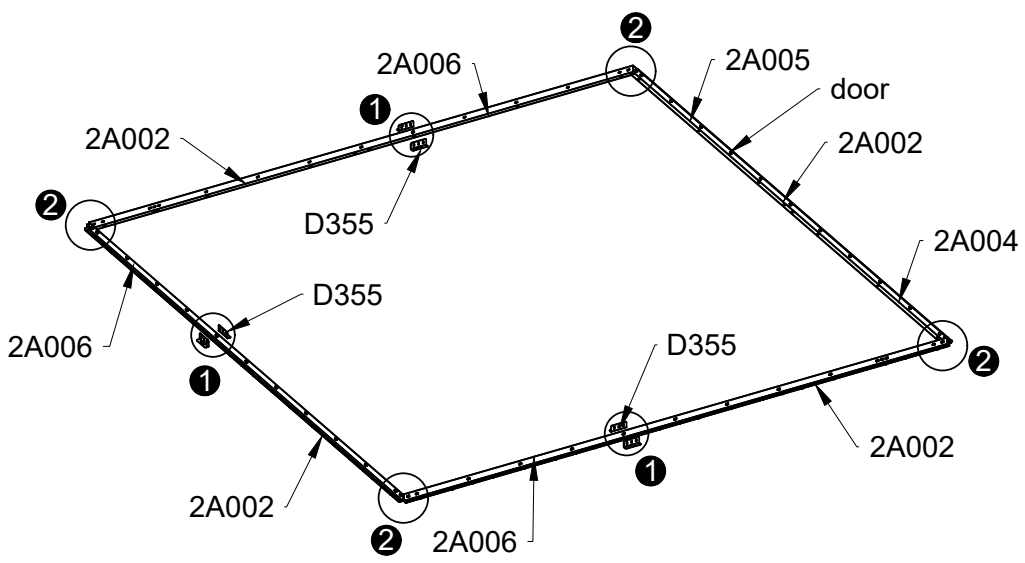

ATTENTION: WHEN CONNECTING 2A002 & 2A004, 2A005, 2A006, PAY ATTENTION TO THE DIRECTION OF 2A004, 2A005, 2A006. THE END WITH NOTCH SHOULD BE FACED TO 2A002 · ATENCIÓN: AL CONECTAR 2A002 CON 2A004, 2A005 Y 2A006, PRESTE ATENCIÓN A LA DIRECCIÓN DE 2A004, 2A005 Y 2A006. EL EXTREMO CON LA MUESCA DEBE MIRAR HACIA 2A002 · ATENÇÃO: AO CONECTAR 2A002 COM 2A004, 2A005 E 2A006, PRESTE ATENÇÃO À DIREÇÃO DE 2A004, 2A005 E 2A006. A EXTREMIDADE COM ENTALHE DEVE ESTAR VOLTADA PARA 2A002 · ATTENTION : LORS DE LA CONNEXION DE 2A002 AVEC 2A004, 2A005 ET 2A006, FAITES ATTENTION AU SENS DE 2A004, 2A005 ET 2A006. L'EXTREMITÉ AVEC ENCOCHE DOIT ÊTRE ORIENTÉE VERS 2A002 · ACHTUNG: ACHTEN SIE BEIM VERBINDEN VON 2A002 MIT 2A004, 2A005 UND 2A006 AUF DIE AUSRICHTUNG VON 2A004, 2A005 UND 2A006. DAS ENDE MIT DER KERBE MUSS ZU 2A002 ZEIGEN · ΠΡΟΣΟΧΗ: ΚΑΤΑ ΤΗ ΣΥΝΔΕΣΗ ΤΟΥ 2A002 ΜΕ ΤΑ 2A004, 2A005 ΚΑΙ 2A006, ΠΡΟΣΕΞΤΕ ΤΗΝ ΚΑΤΕΥΘΥΝΣΗ ΤΩΝ 2A004, 2A005 ΚΑΙ 2A006. ΤΟ ΑΚΡΟ ΜΕ ΤΗΝ ΕΓΚΟΠΗ ΠΡΕΠΕΙ ΝΑ ΕΙΝΑΙ ΣΤΡΑΜΜΕΝΟ ΠΡΟΣ ΤΟ 2A002 · ATTENZIONE: QUANDO SI COLLEGA 2A002 CON 2A004, 2A005 E 2A006, PRESTARE ATTENZIONE ALLA DIREZIONE DI 2A004, 2A005 E 2A006. L'ESTREMITÀ CON LA TACCA DEVE ESSERE RIVOLTA VERSO 2A002 · POZOR: PŘI SPÁJANÍ 2A002 S 2A004, 2A005 A 2A006 VENUJTE POZORNOST SMĚRU 2A004, 2A005 A 2A006. KONIEC SO ZÁREZOM MUSÍ SMĚROVAT K 2A002 · POZOR: PŘI POVEZOVANÍ 2A002 S 2A004, 2A005 I 2A006, OBRATITE POZORNOST NA SMĚR 2A004, 2A005 I 2A006. KRAJ S UREZOM MORA BITI OBRNEN PROTÍ 2A002 · OBSERVERA: VID ANSLUTNING AV 2A002 MED 2A004, 2A005 OCH 2A006, VAR UPPMÄRKSAM PÅ RIKTNINGEN FÖR 2A004, 2A005 OCH 2A006. ÄNDEN MED JACK SKA VARA VÄND MOT 2A002 · DIKKAT: 2A002 ILE 2A004, 2A005 VE 2A006'YI BAĞLARKEN 2A004, 2A005 VE 2A006'NİN YÖNÜNE DIKKAT EDİN. ÇENTİKLİ UÇ 2A002'YE BAKMALIDIR · JDES: GJATÉ LIDHJES SË 2A002 ME 2A004, 2A005 DHE 2A006, KUSHTOJINI VËMENDJE DREJTIMIT TË 2A004, 2A005 DHE 2A006. FUNDI ME DNËMBEZIM DUNËT TË JETË I KTHYER NGA 2A002 · ВНИМАНИЕ: ПРИ СОЕДИНЕНИИ 2A002 С 2A004, 2A005 И 2A006 ОБРАТИТЕ ВНИМАНИЕ НА НАПРАВЛЕНИЕ 2A004, 2A005 И 2A006. КОНЕЦ С ВЫЕМКОЙ ДОЛЖЕН БЫТЬ ОБРАЩЕН К 2A002 · UWAGA: PODCZAS ŁĄCZENIA 2A002 Z 2A004, 2A005 I 2A006 ZWRÓĆ UWAGĘ NA KIERUNEK 2A004, 2A005 I 2A006. KONIEC Z WYCIECIEM POWINIEN BYĆ SKIEROWANY W STRONĘ 2A002 · FIGYELEM: A 2A002 ÉS A 2A004, 2A005, 2A006 CSATLAKOZTATÁSAKOR ÜGYELJEN A 2A004, 2A005 ÉS 2A006 IRÁNYÁRA. A HORONNYAL ELLÁTOTT VÉGNEK A 2A002 FELÉ KELL NÉZNI



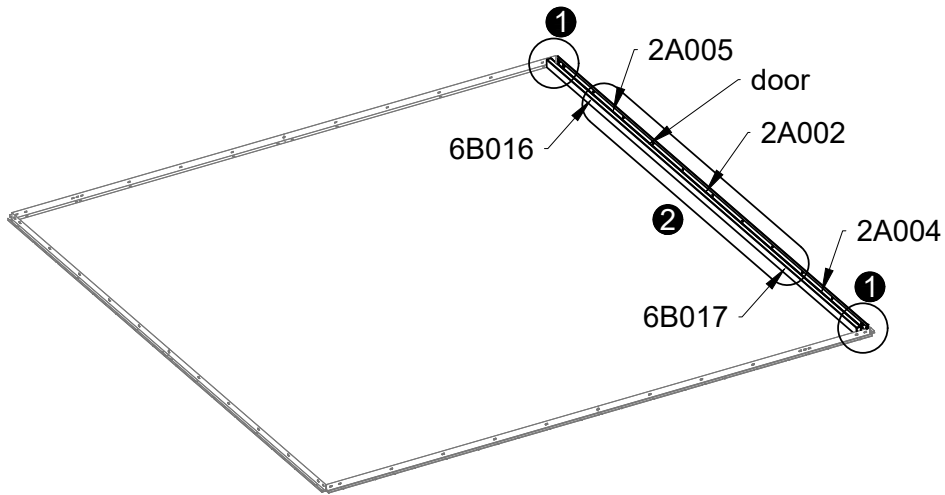
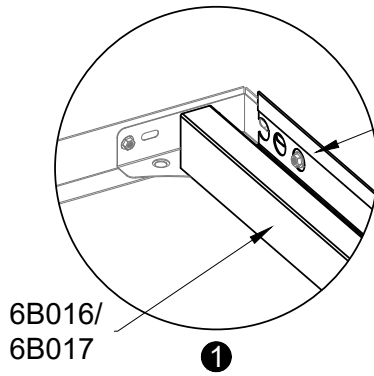

PART	NO	QTY
	6B016	1
	6B017	1
	S74	10
	M4X8	
	M25	10
	M4	



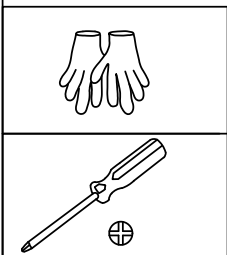
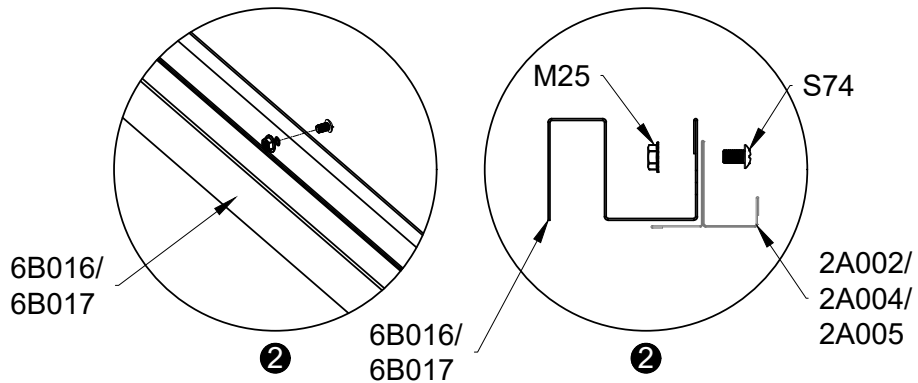

INSTALL ONLY THE MIDDLE 10 HOLES · INSTALE SOLO LOS 10 AGUJEROS CENTRALES · INSTALE APENAS OS 10 FURROS CENTRAIS · INSTALLEZ UNIQUEMENT LES 10 TROUS DU MILIEU · INSTALLIEREN SIE NUR DIE MITTLEREN 10 LÖCHER · ΤΟΠΟΘΕΤΗΣΤΕ ΜΟΝΟ ΤΙΣ 10 ΜΕΣΑΙΕΣ ΤΡΥΠΕΣ · INSTALLARE SOLO I 10 FORI CENTRALI · NAINŠTALUJTE IBA PROSTREDNÝCH 10 OTVOROV · UGRADITE SAMO SREDNJIH 10 RUPA · NAMONTUJTE POUZE PROSTREDNÝCH 10 OTVORŮ · NAMESTITE SAMO SREDNIH 10 LUKENJ · INSTALLERA ENDAST DE 10 MITTERŠTA HÅLEN · SADECE ORTADAKI 10 DE-LIGI MONTE EDIN · INSTALONI VETĚM 10 VRIMAT E MESIT · УСТАНОВИТЕ ТОЛЬКО 10 СРЕДНИХ ОТВЕРСТИЙ · ZAMONTUJ TYLKO 10 ŚRODKOWYCH OTWORÓW · CSAK A KÖZÉPSŐ 10 FURATOT SZERELJE BE



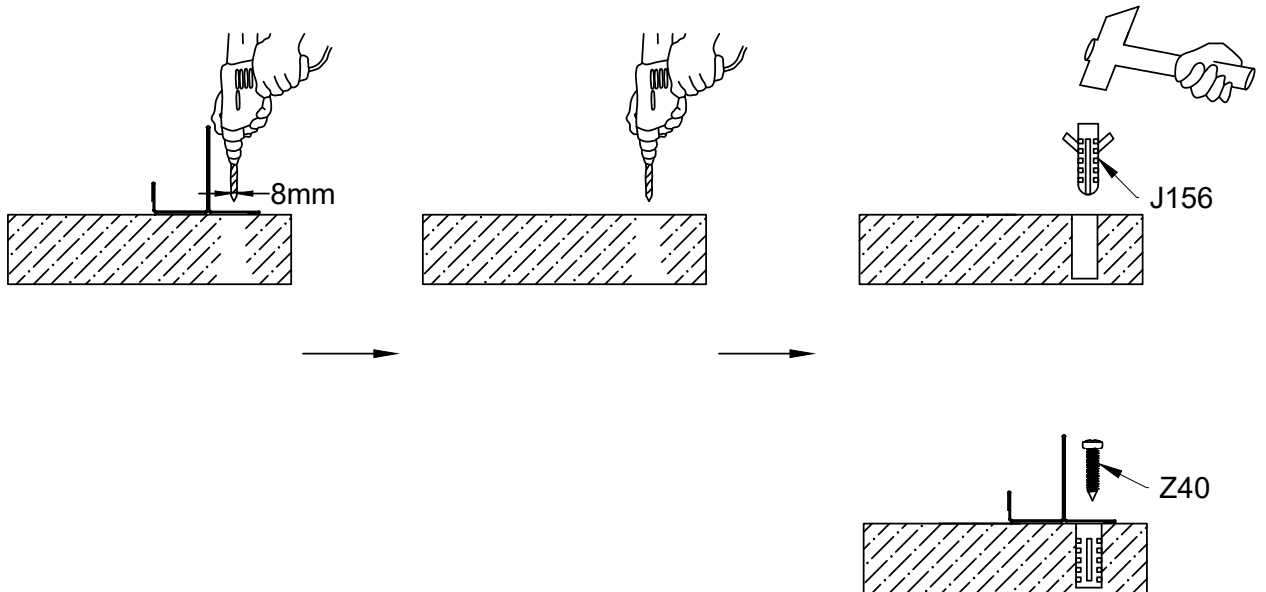
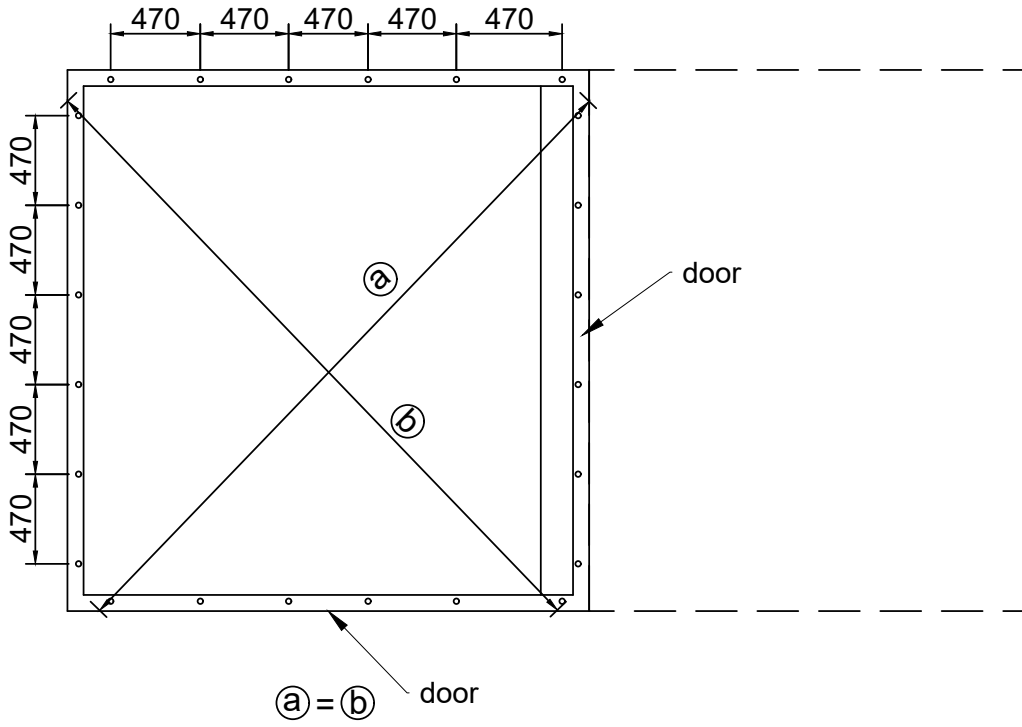



PART	NO	QTY
	J156	24
	Z40 M5X40	24

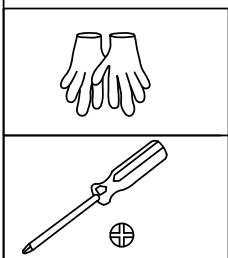
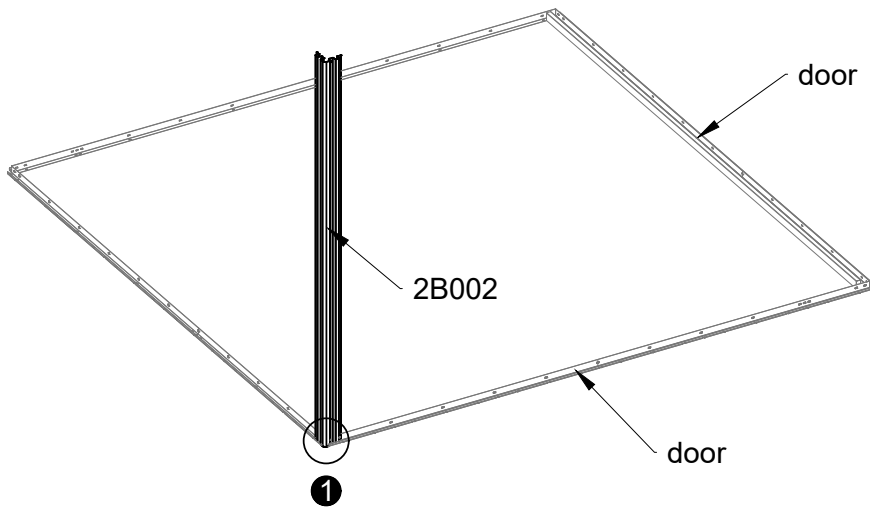
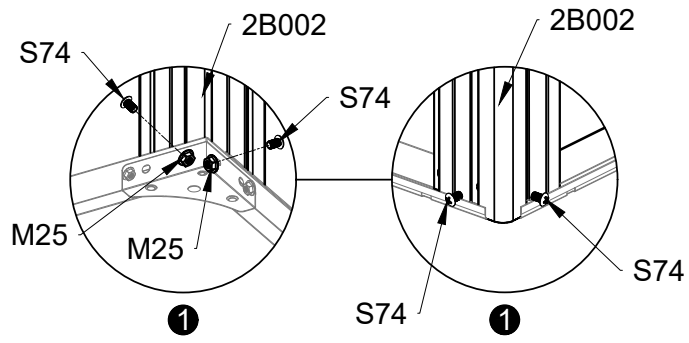

PART	NO	QTY
	2B002	1
	S74	2
	M4X8	
	M25	2
	M4	



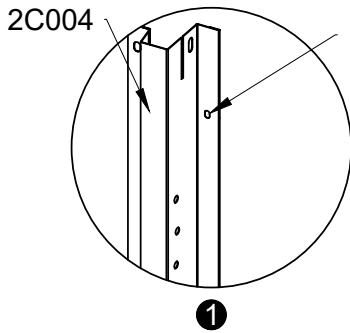
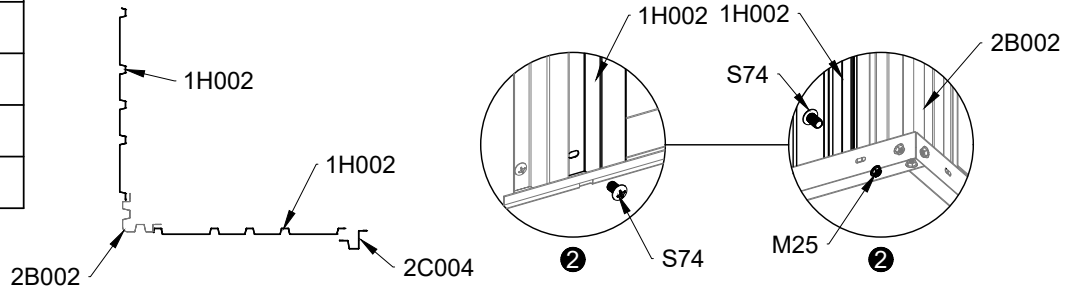

PART	NO	QTY
	1H002	2
	2C004	1
	S74 M4X8	8
	M25 M4	8



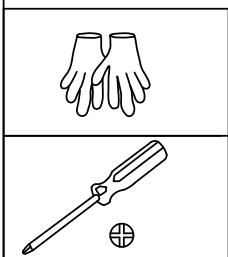
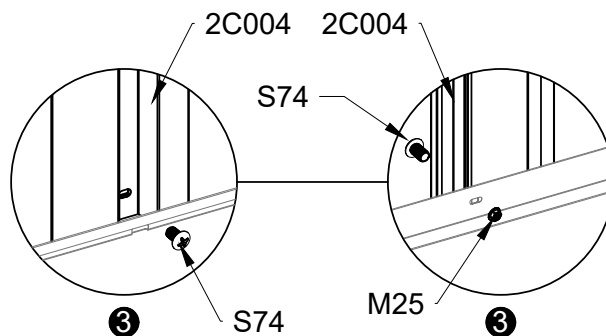
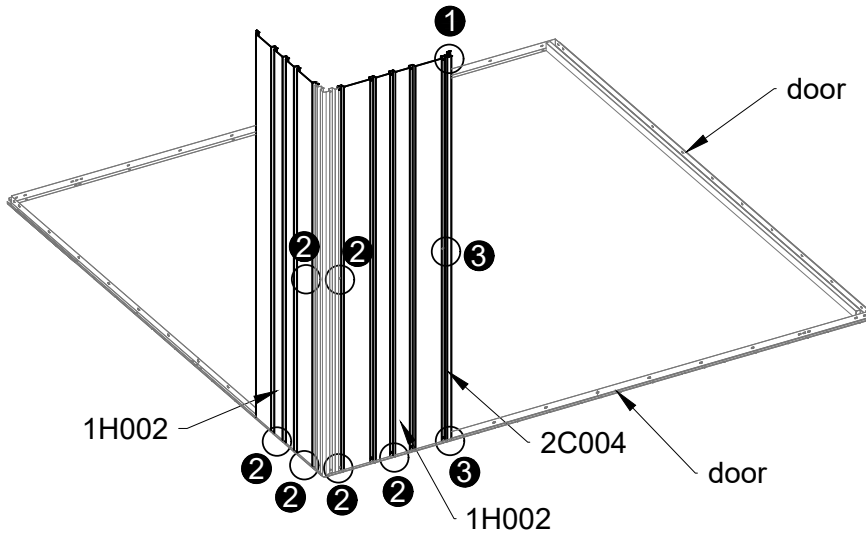



THE HOLE POSITION SHOULD FACE UPWARD · LA POSICIÓN DEL AGUJERO DEBE MIRAR HACIA ARRIBA · A POSIÇÃO DO FURO DEVE ESTAR VOLTADA PARA CIMA · LA POSITION DU TROU DOIT ÊTRE TOURNÉE VERS LE HAUT · DIE LOCHPOSITION SOLLTE NACH OBEN ZEIGEN · Η ΘΕΣΗ ΤΗΣ ΤΡΥΠΑΣ ΠΡΕΠΕΙ ΝΑ ΕΙΝΑΙ ΣΤΡΑΜΜΕΝΗ ΠΡΟΣ ΤΑ ΠΑΝΩ · LA POSIZIONE DEL FORO DEVE ESSERE RIVOLTA VERSO L'ALTO · POLOHA OTVORU BY MALA SMEROVAŤ NAHOR · POLOŽAJ RUPE TREBA BITI OKRENUŤ PREMA GORE · POLOHA OTVORU BY MEĽA SMEROVAŤ NAHORU · POLOŽAJ LUKNJE MORA BITI OBRNĀEN NAVZGOR · HÁLETS POSITION SKA VARA VĀND UPPĀT · DELIK KONUMU YUKARI BAKMALIDIR · POZICIONI I VRIMĒS DUHĒT TĒ JĒTĒ I KTHYER LART · ОТВЕРСТІЄ ДОЛЖНО БЫТЬ НАПРАВЛĒНО ВВЕРХ · POŁOŻENIE OTWORU POWINNO BYĆ SKIEROWANE DO GÓRY · A FURAT HELYZETĒNEK FELFELĒ KELL NĒZNE

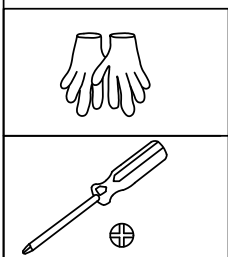
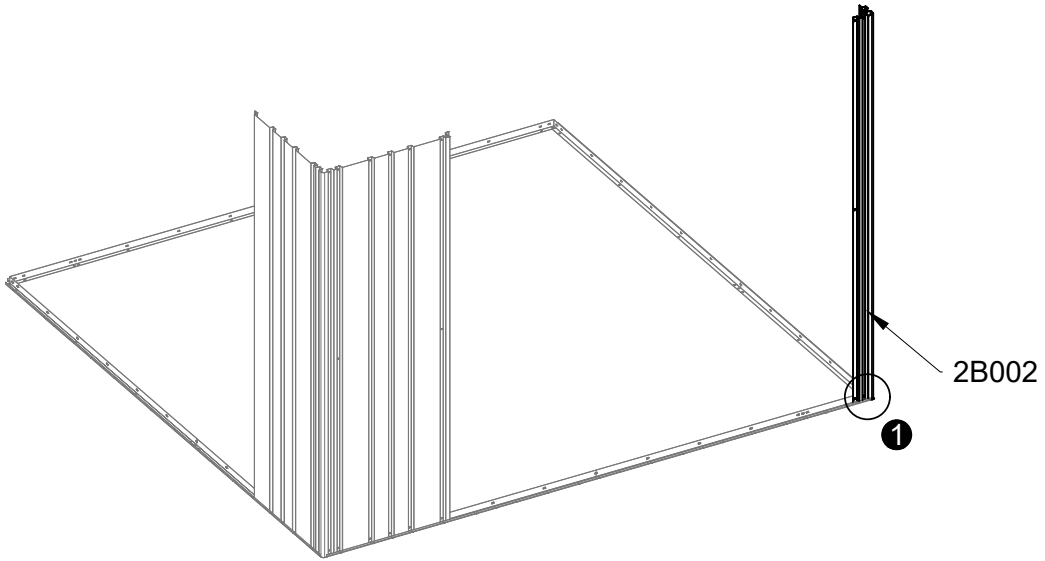
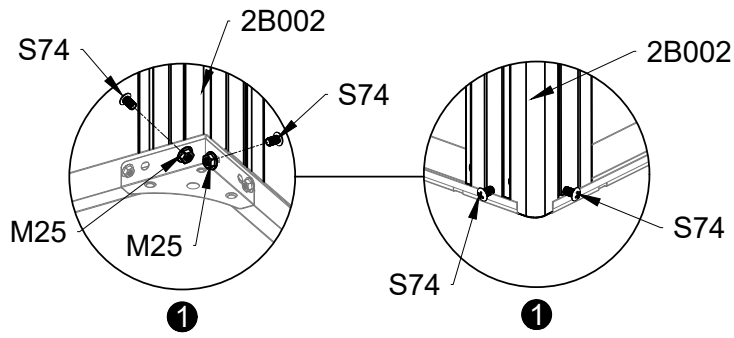

PART	NO	QTY
	2B002	1
	S74 M4X8	2
	M25 M4	2



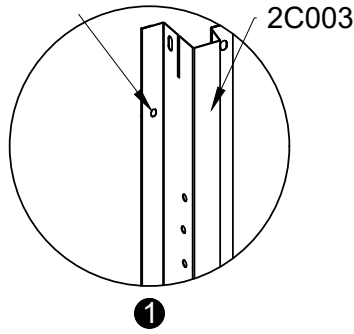

PART	NO	QTY
	1H002	1
	1H021	1
	2C003	1
	S74	8
	M4X8	
	M25	8
	M4	



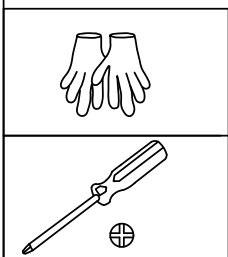
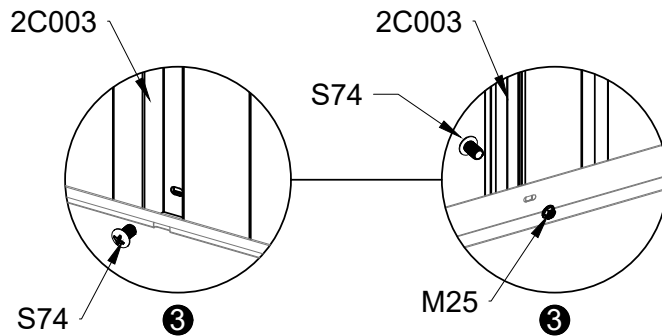
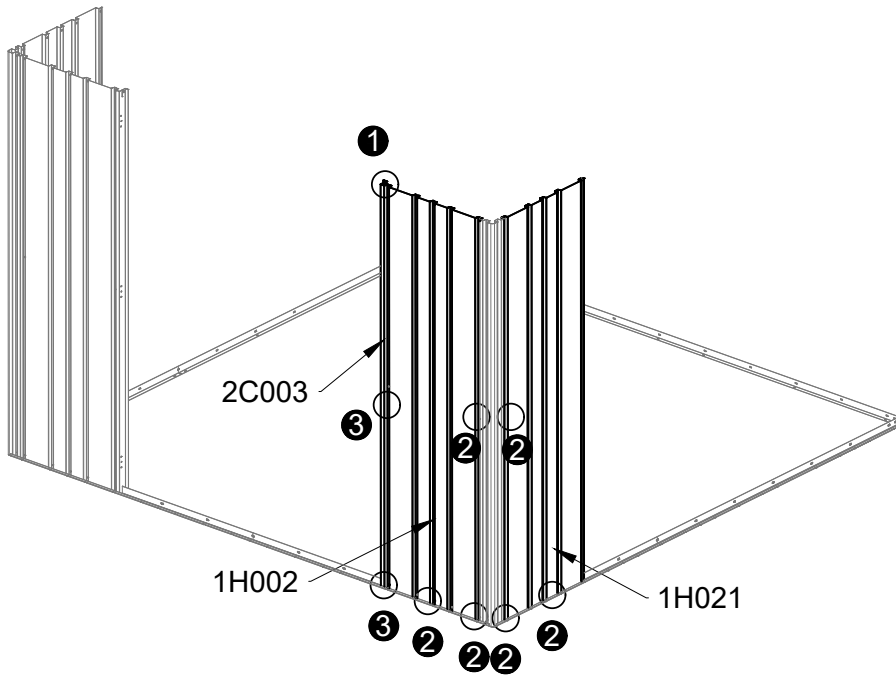
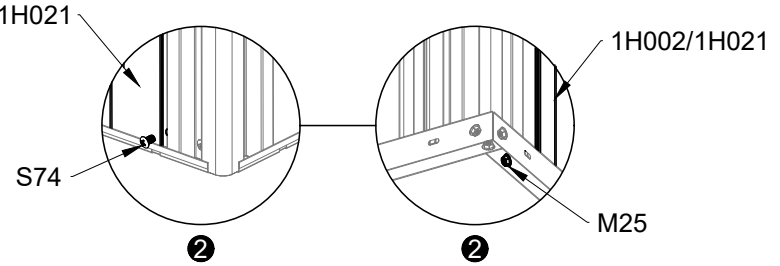
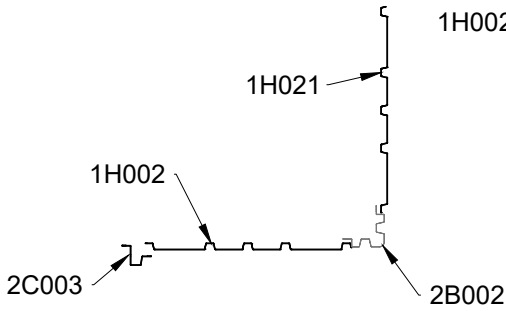

THE HOLE POSITION SHOULD FACE UPWARD · LA POSICIÓN DEL AGUJERO DEBE MIRAR HACIA ARRIBA · A POSIÇÃO DO FURO DEVE ESTAR VOLTADA PARA CIMA · LA POSITION DU TROU DOIT ÊTRE TOURNÉE VERS LE HAUT · DIE LOCHPOSITION SOLLTE NACH OBEN ZEIGEN · Η ΘΕΣΗ ΤΗΣ ΤΡΥΠΑΣ ΠΡΕΠΕΙ ΝΑ ΕΙΝΑΙ ΣΤΡΑΜΜΕΝΗ ΠΡΟΣ ΤΑ ΠΑΝΩ · LA POSIZIONE DEL FORO DEVE ESSERE RIVOLTA VERSO L'ALTO · POLOHA OTVORU BY MALA SMEROVAŤ NAHOR · POLOŽAJ RUPE TREBA BITI OKRENUT PREMA GORE · POLOHA OTVORU BY MĚLA SMĚROVAT NAHORU · POLOŽAJ LUKNJE MORA BITI OBRNJEŃ NAVZGOR · HAĽETS POSITION SKA VARA VĀND UPĀT · DELIK KONUMU YUKARI BAKMALIDIR · POZICIONI I VRIMĚS DUHET TĚ JETĚ I KŤHYER L'ART · ОТВЕРСТИЕ ДОЛЖНО БЫТЬ НАПРАВЛЕНО ВВЕРХ · POŁOŻENIE OTWORU POWINNO BYĆ SKIEROWANE DO GÓRY · A FURAT HELYZETÉNEK FELFELÉ KELL NÉZNIÉ



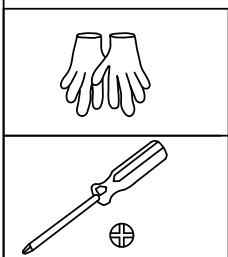
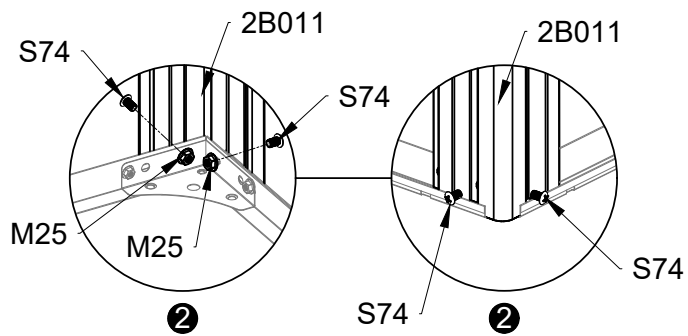
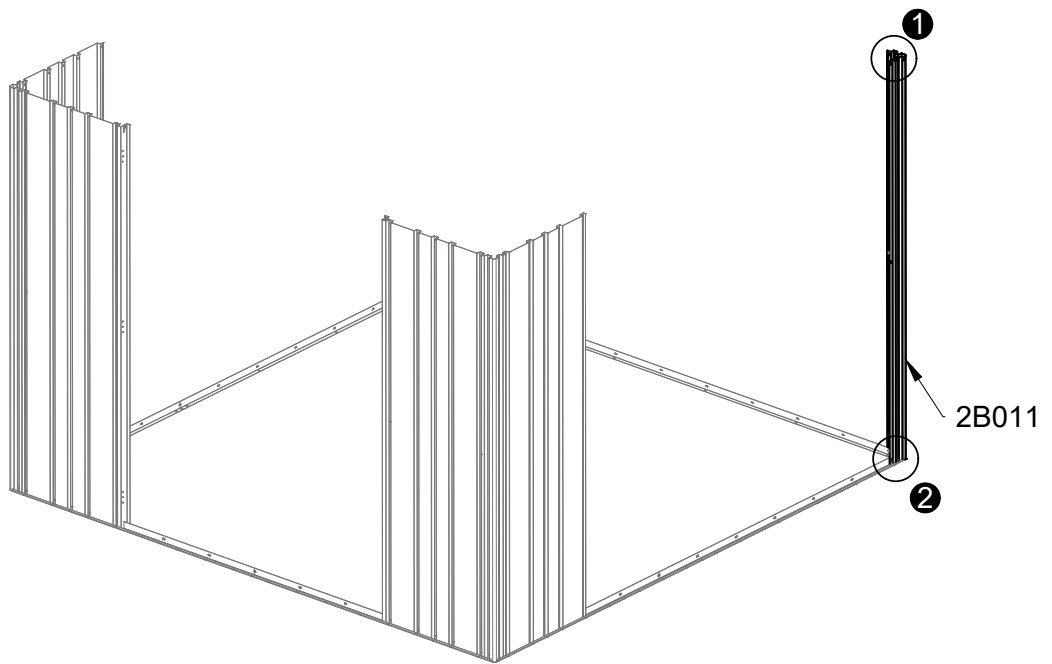
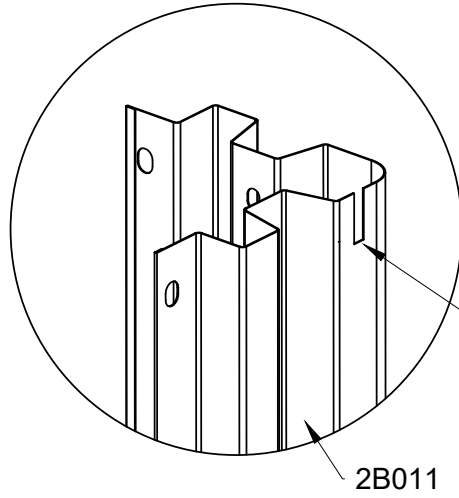

PART	NO	QTY
	2B011	1
	S74 M4X8	2
	M25 M4	2



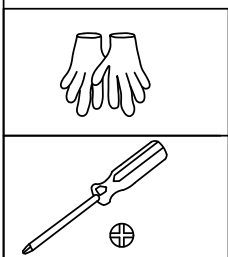
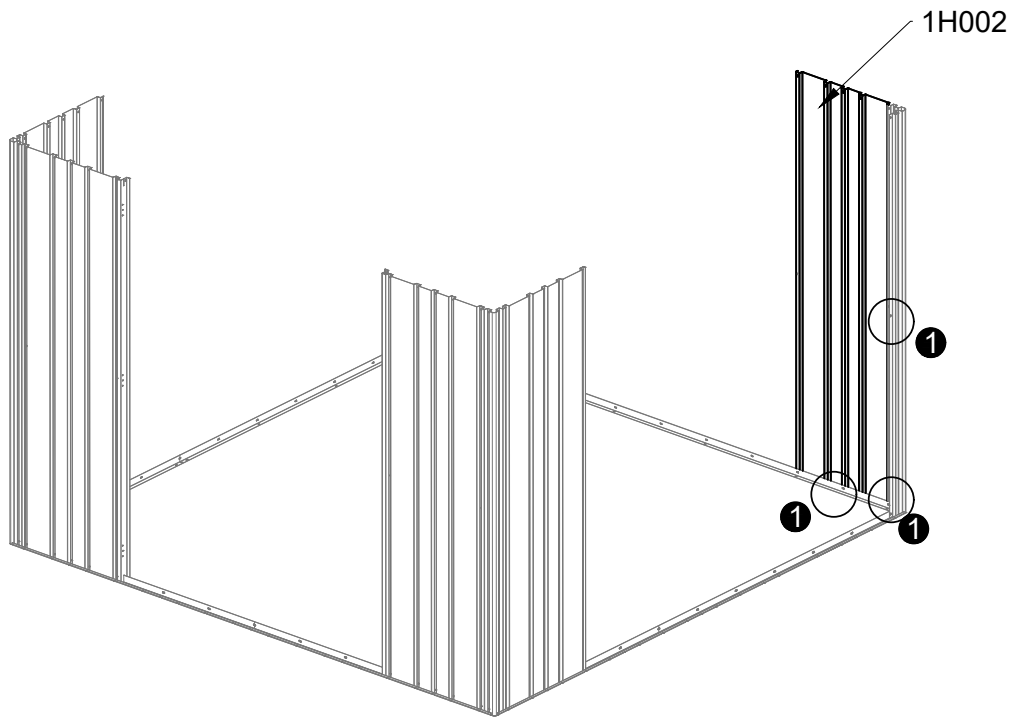
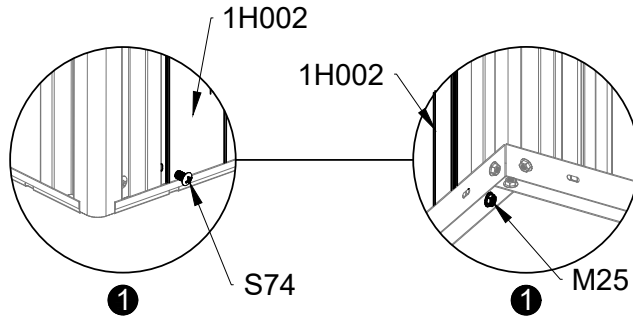

PART	NO	QTY
	1H002	1
	S74 M4X8	3
	M25 M4	3



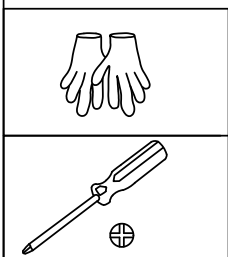
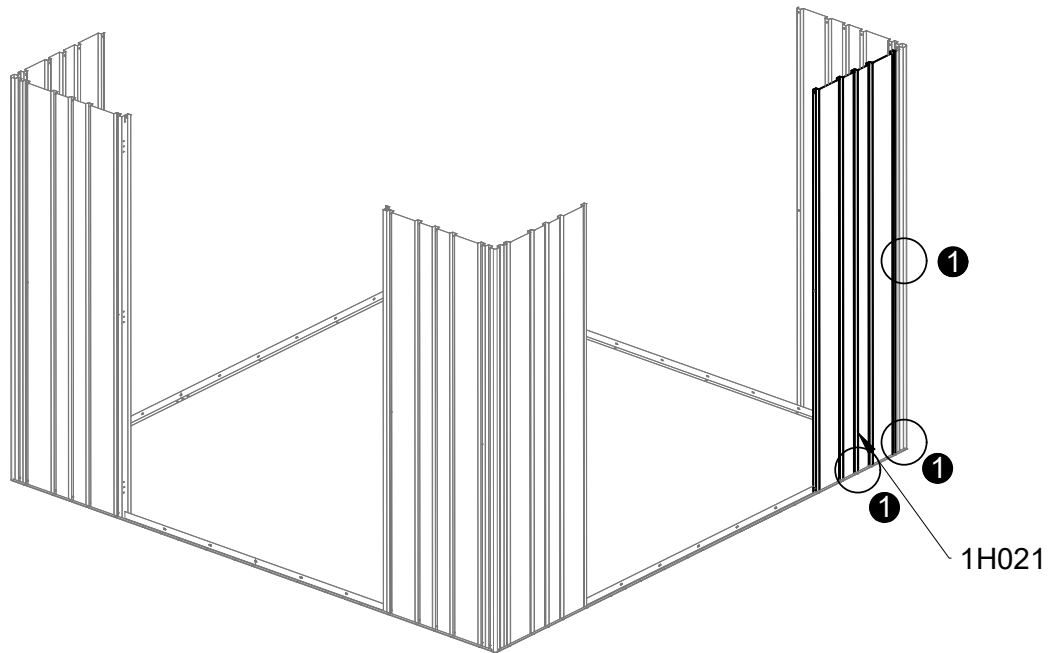
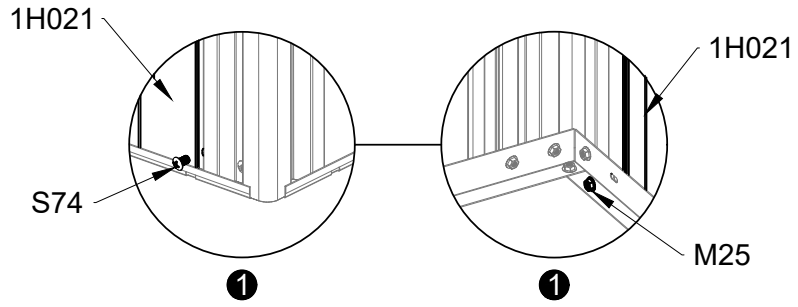

PART	NO	QTY
	1H021	1
	S74 M4X8	3
	M25 M4	3



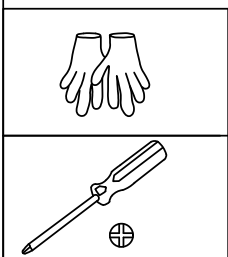
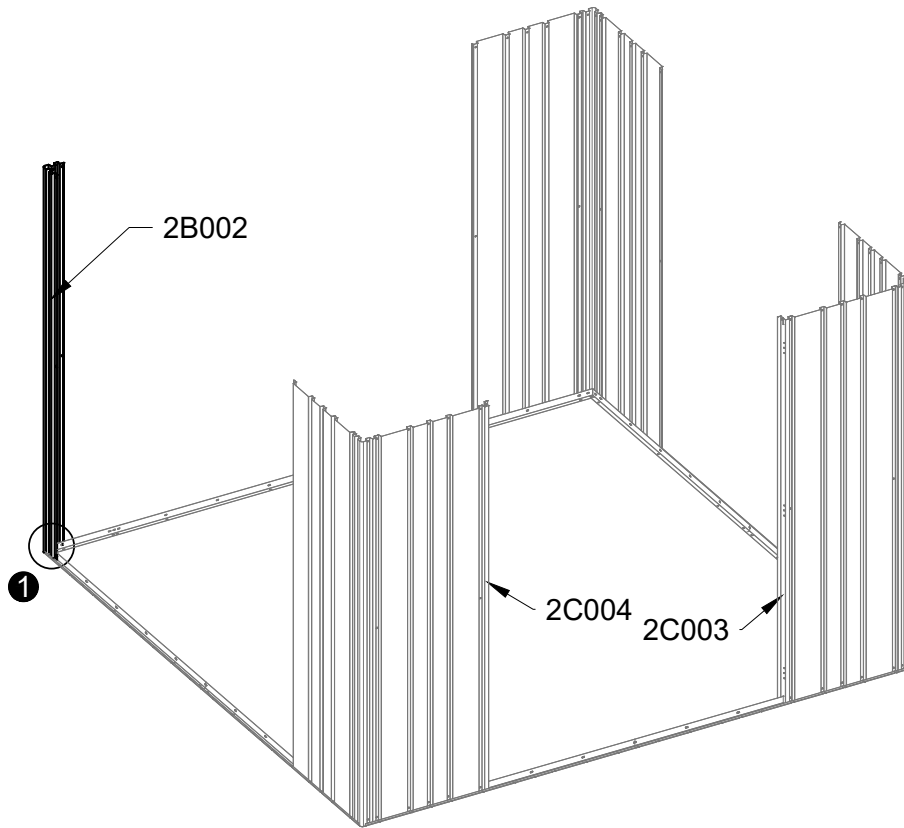
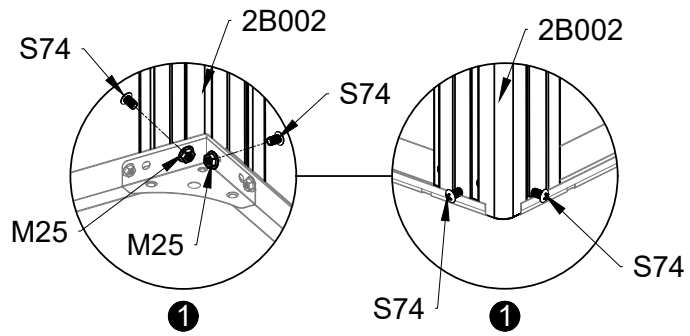





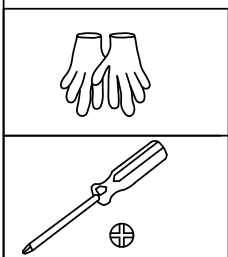
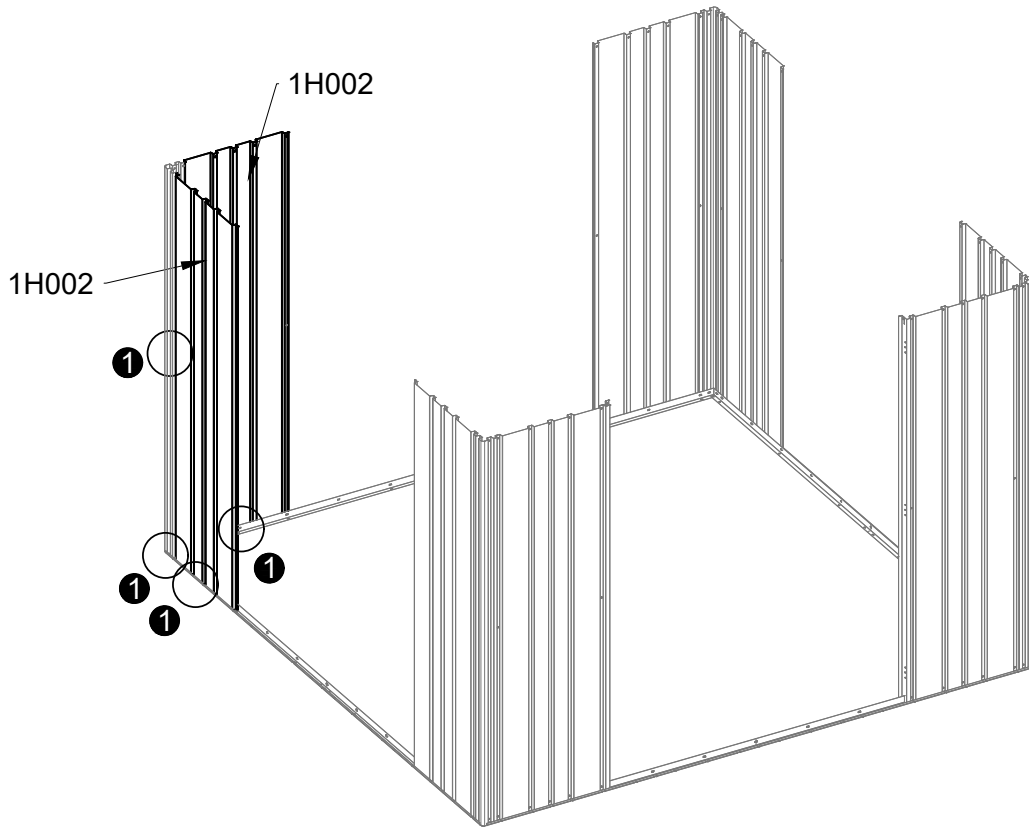
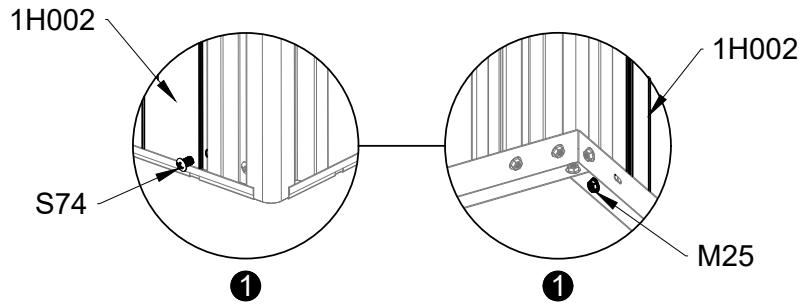



PART	NO	QTY
	2B002	1
	S74 M4X8	2
	M25 M4	2





PART	NO	QTY
	1H002	2
	S74 M4X8	6
	M25 M4	6



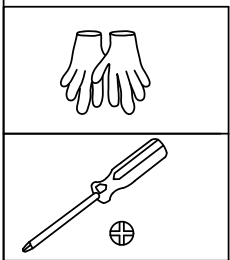
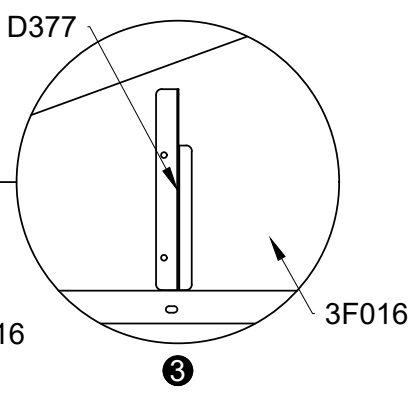
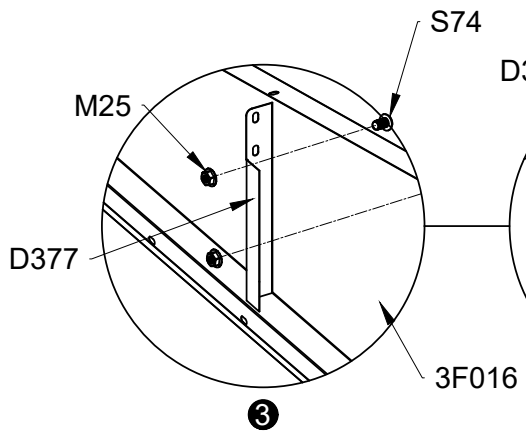
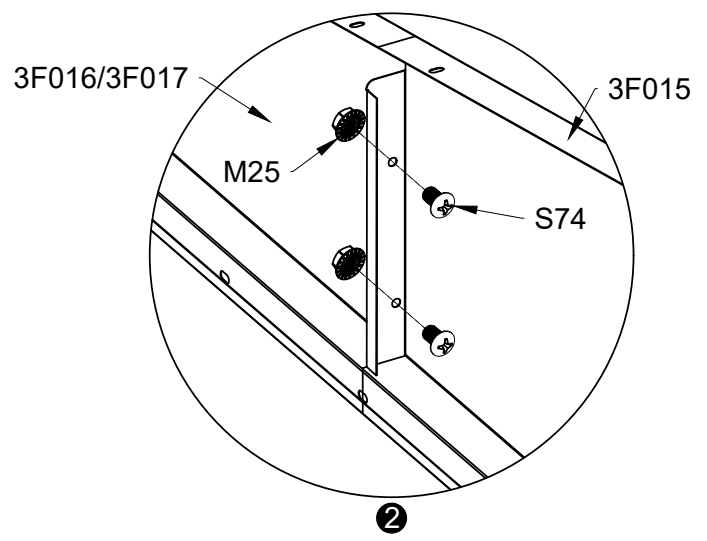
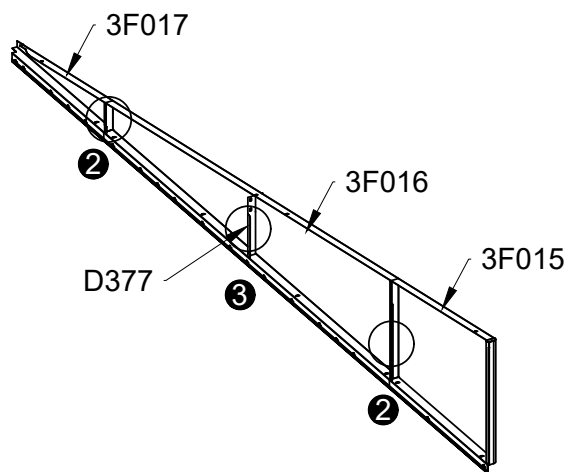
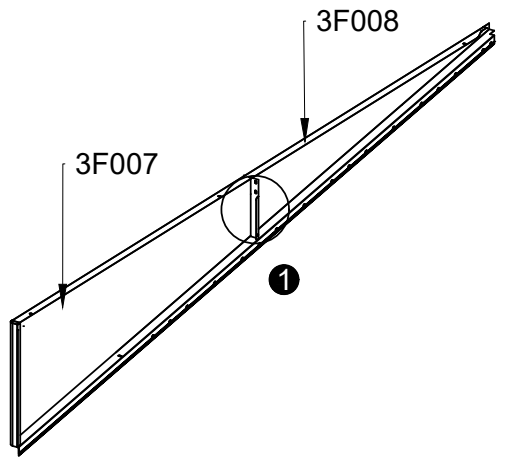
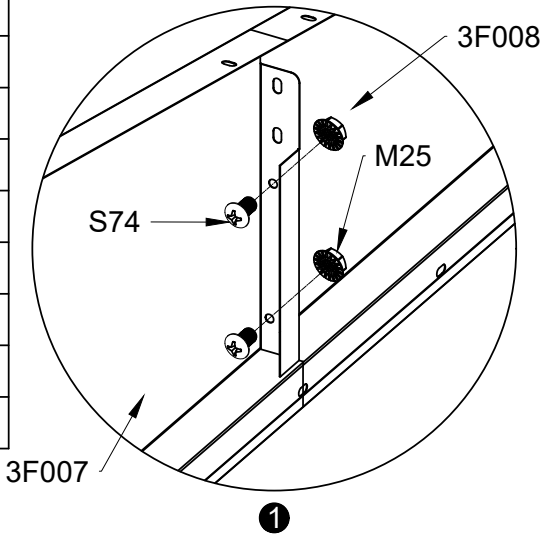



PART	NO	QTY
	3F007	1
	3F008	1
	3F015	1
	3F016	1
	3F017	1
	D377	1
	S74	8
	M4X8	
	M25	8
	M4	

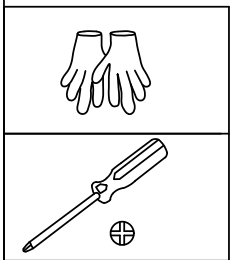
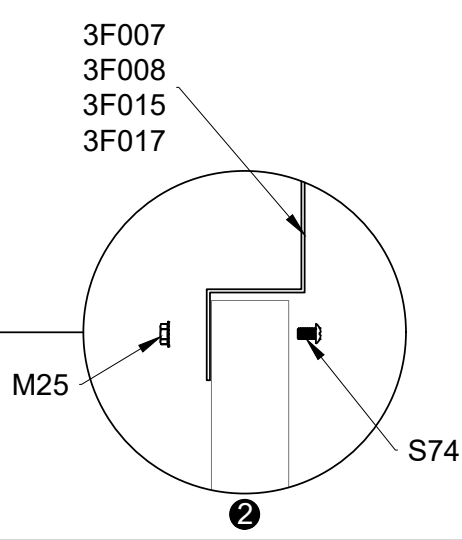
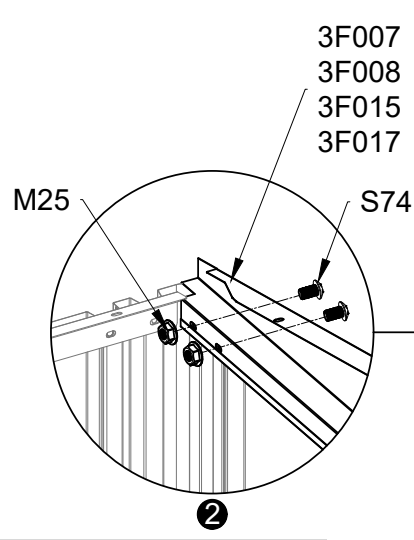
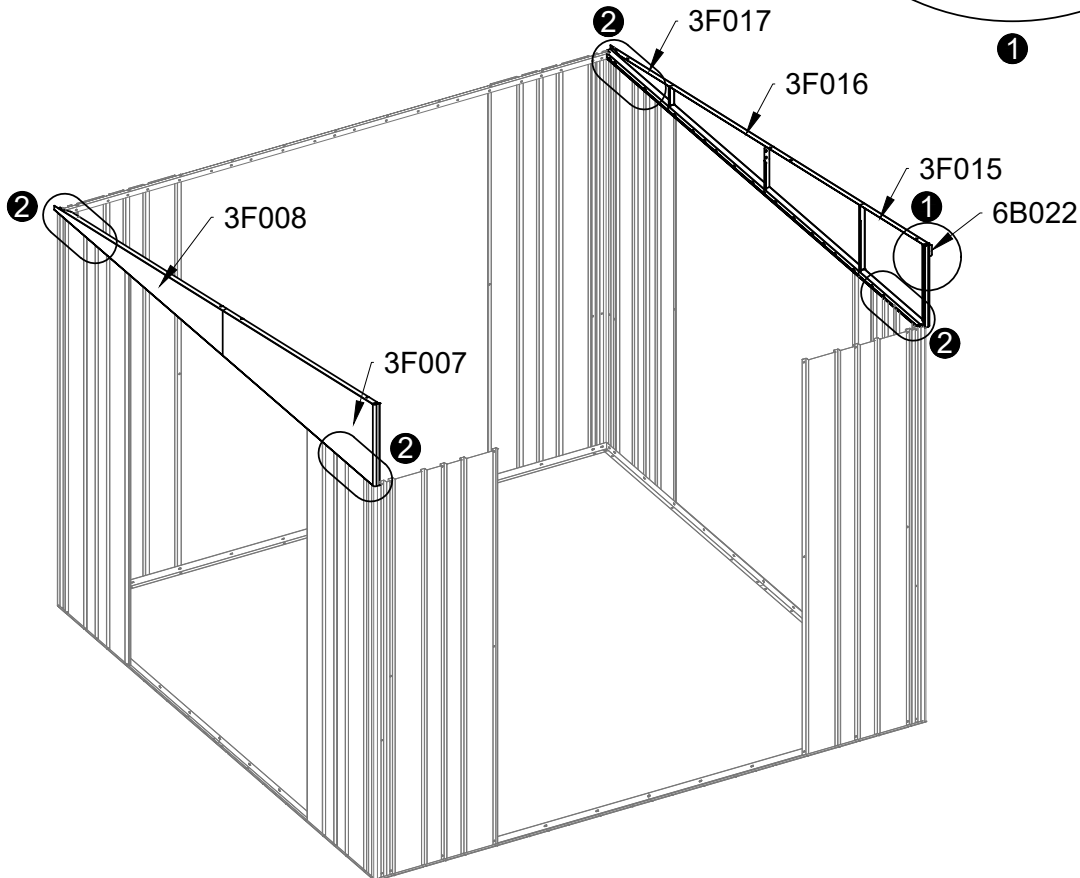
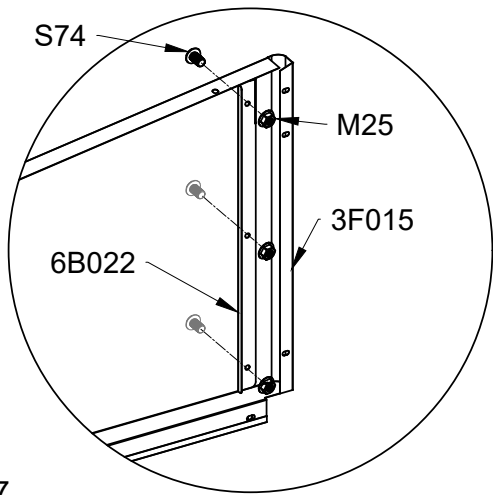





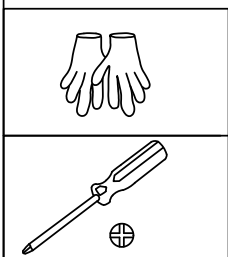
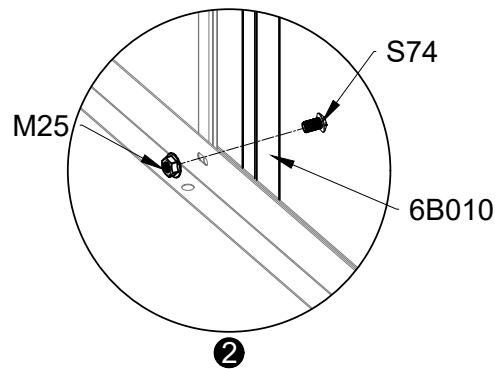
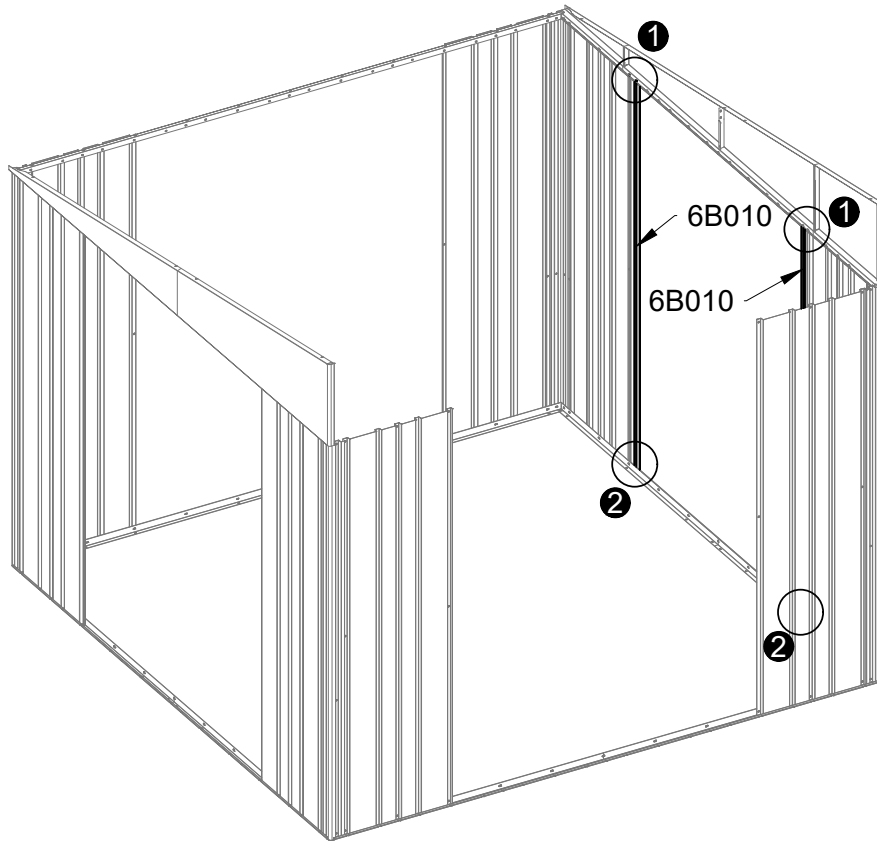
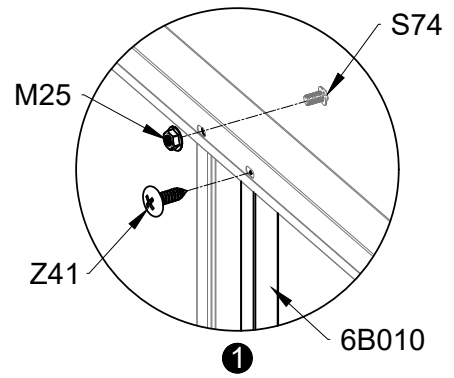

PART	NO	QTY
	S74	23
	M4X8	
	M25	23
	M4	



PART	NO	QTY
	6B010	2
	Z41 M4.2X10	2
	S74 M4X8	4
	M25 M4	4



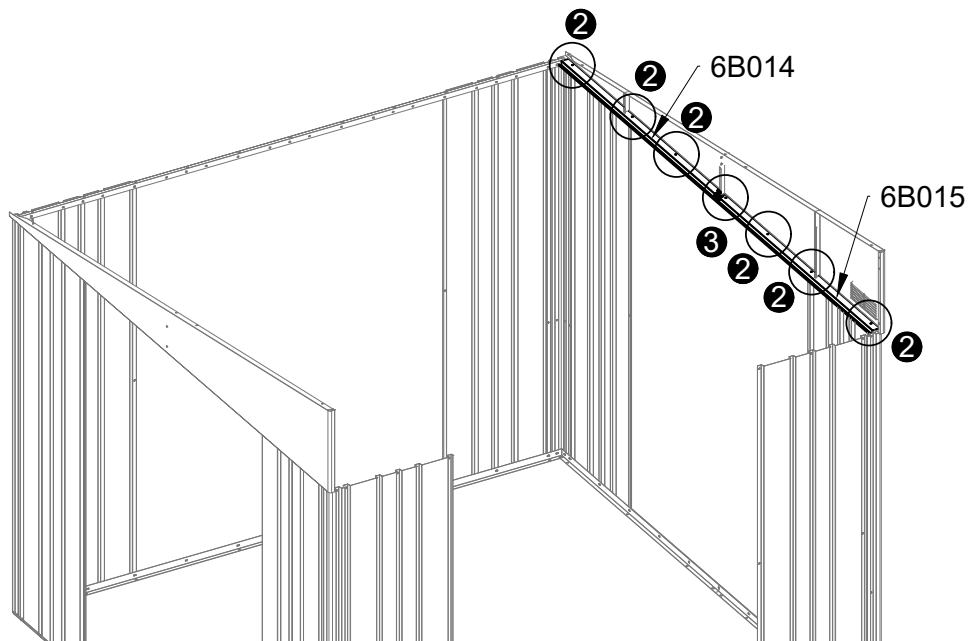
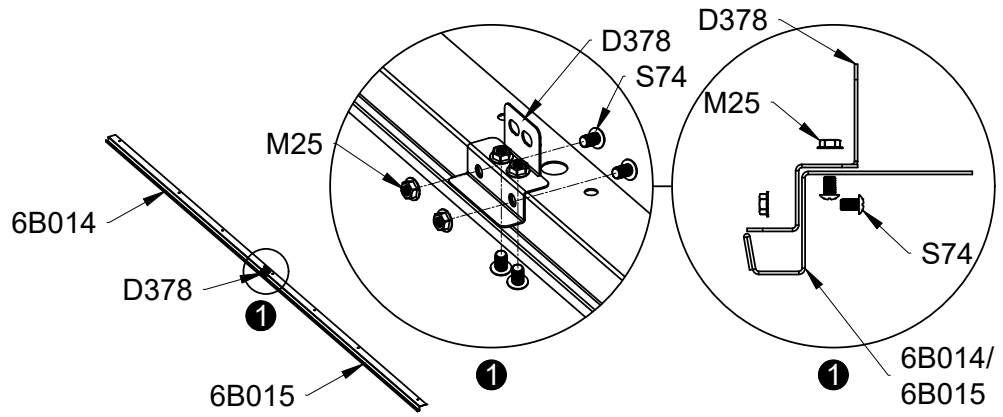

PART	NO	QTY
	6B014	1
	6B015	1
	D378	1
	S63	2
	M4X12	
	S74	12
	M4X8	
	M25	14
	M4	

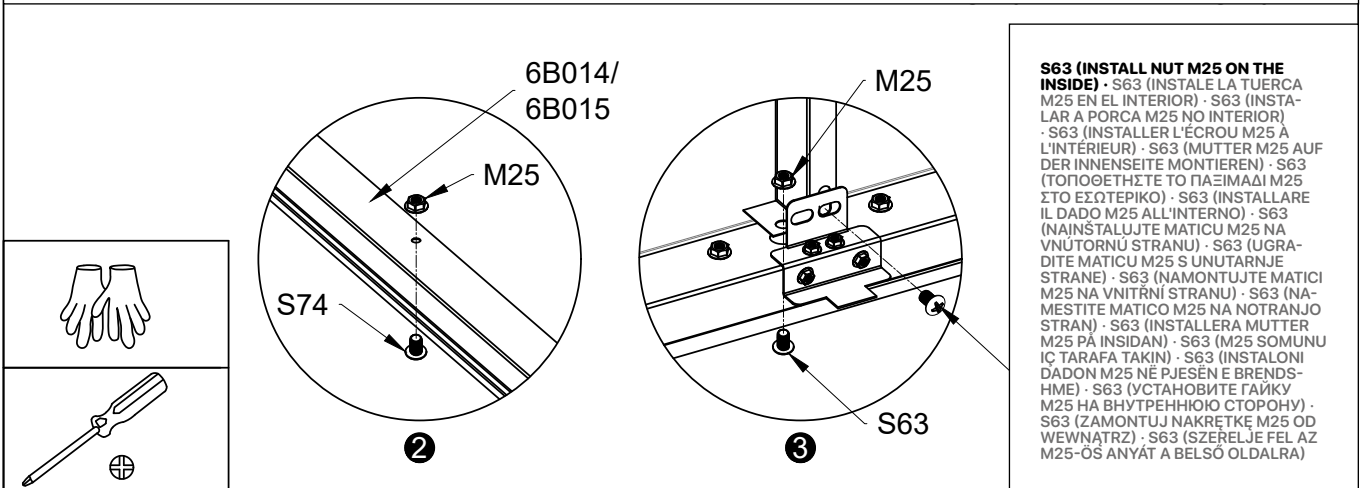

SCREW S63 IS USED TO ADJUST THE BALANCE OF THE DOOR. AT THIS POINT, LOCK IT SLIGHTLY, DON'T LOCK IT TIGHTLY · EL TORNILLO S63 SE UTILIZA PARA AJUSTAR EL EQUILIBRIO DE LA PUERTA. EN ESTE PUNTO, APRIÉTELO LIGERAMENTE, NO LO APRIETE DEL TODO · O PARAFUSO S63 É USADO PARA AJUSTAR O EQUILIBRIO DA PORTA. NESTE PONTO, APORTE-O LIGEIRAMENTE, NÃO O APORTE TOTALMENTE · LA VIS S63 EST UTILISÉE POUR RÉGLER L'ÉQUILIBRE DE LA PORTE. À CE STADE, SERREZ-LA LÉGÈREMENT, NE LA SERREZ PAS À FOND · DIE SCHRAUBE S63 DIENST ZUM EINSTELLEN DES TÜRGLEICHGEWICHTS. ZIEHEN SIE SIE AN DIESER STELLE NUR LEICHT AN, NICHT FESTZIEHEN · Η ΒΙΔΑ S63 ΧΡΗΣΙΜΟΠΟΙΕΙΤΑΙ ΓΙΑ ΤΗ ΡΥΘΜΙΣΗ ΤΗΣ ΙΣΟΡΡΟΠΙΑΣ ΤΗΣ ΠΟΡΤΑΣ. ΣΕ ΑΥΤΟ ΤΟ ΣΗΜΕΙΟ, ΑΣΦΑΛΙΣΤΕ ΤΗΝ ΕΛΑΦΡΑ, ΜΗΝ ΤΗ ΣΦΙΞΕΤΕ ΔΥΝΑΤΑ · LA VITE S63 SERVE PER REGOLARE L'EQUILIBRIO DELLA PORTA. A QUESTO PUNTO, AVVITARLA LEGGERMENTE, NON SERRARLA A FONDO · SKRŮTKA S63 SA POUŽIVA NA NASTAVENÍ VYVÁŽENÍ DVEŘÍ. V TOMTO BODĚ JEJ DOTAHNĚTE POUZE LEHCE, NEDOTAHNĚTE JEJ PEVNĚ · VIJAK S63 SE UPORABLJA ZA NASTAVITEV RAVNOVESJA VRAT. NA TEJ TOČKI GA LE RAHLO PRIVIJTE, NE ZATEGNITE GA MOČNO · SKRUV S63 ANVÄNDS FÖR ATT JUSTERA DÖRRENS BALANS. I DETTA SKEDE, LÅS DEN LÅTT, LÅS DEN INTE HÅRT · S63 VIDASI KAPİ DENGESİNİ AYARLAMAK İÇİN KULLANILIR. BU NOKTADA HAFİFCE SIKIN, TAM OLARAK SIKIŞTIRMAYIN · VIDA S63 PĚRDORĚT PĚR TĚ RREGULLUAR BALANCĚN E DERĚS. NĚ KĚTĚ PIKĚ, SHTRĚNGOJENÍ PAK, MOS E SHTRĚNGONI FORT · ВИНТ S63 ИСПОЛЬЗУЕТСЯ ДЛЯ РЕГУЛИРОВКИ БАЛАНСА ДВЕРИ. НА ДАННОМ ЭТАПЕ СЛЕГКА ПОДТЯНИТЕ ЕГО, НЕ ЗАТЯГИВАЙТЕ ПЛОТНО · ŚRUBA S63 SŁUŻY DO REGULACJI WYWAŻENIA DRZWI. W TYM MOMENCIE DOKRĘĆ JĄ LEKKO, NIE DOKRĘCAJ JEJ MOCNO · AZ S63-AS CSAVAR AZ AJTÓ EGYENSÚLYÁNAK BEÁLLÍTÁSÁRA SZOLGÁL. EZEN A PONTON CSAK ENYHĚN HÚZZA MEG, NE HÚZZA MEG SZOROSAN



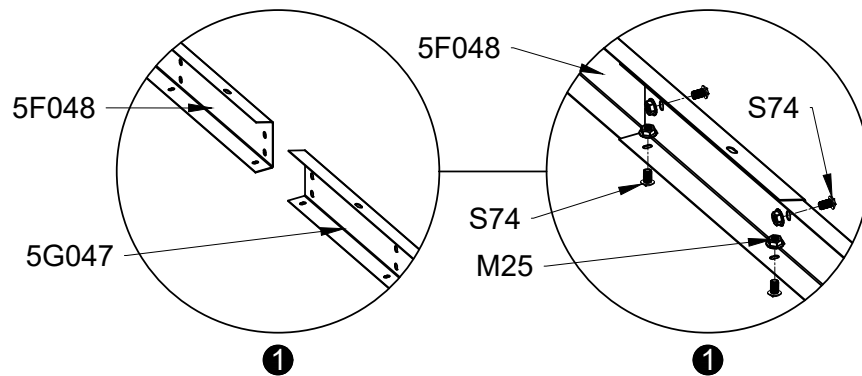
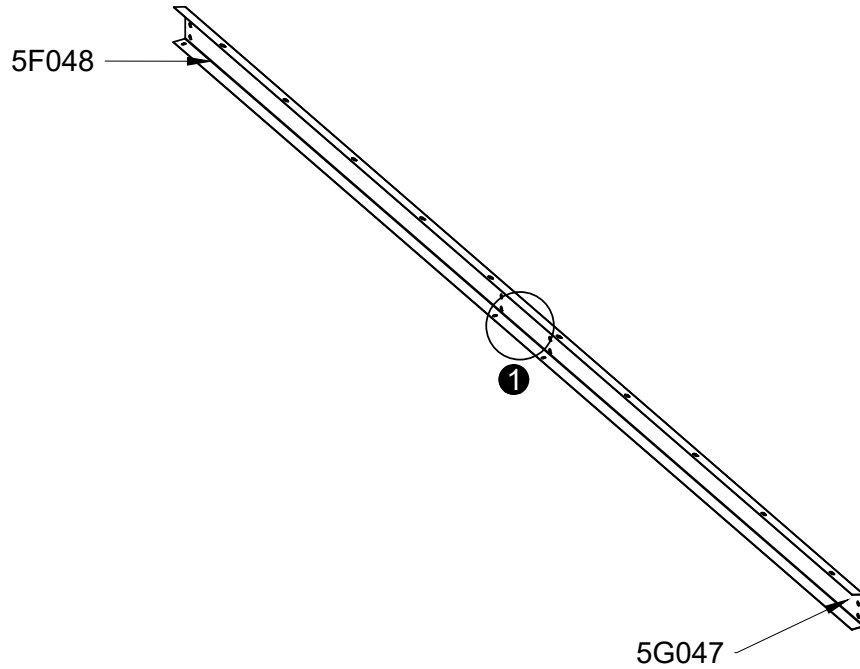

S63 (INSTALL NUT M25 ON THE INSIDE) · S63 (INSTALE LA TUERCA M25 EN EL INTERIOR) · S63 (INSTALAR A PORCA M25 NO INTERIOR) · S63 (INSTALLER L'ÉCROU M25 À L'INTÉRIEUR) · S63 (MUTTER M25 AUF DER INNENSEITE MONTIEREN) · S63 (ΤΟΠΟΘΕΤΗΣΤΕ ΤΟ ΠΑΞΙΜΑΔΙ Μ25 ΣΤΟ ΕΣΩΤΕΡΙΚΟ) · S63 (INSTALLARE IL DADO M25 ALL'INTERNO) · S63 (NAINŠTALUJTE MATICU M25 NA VNĚTORNŮ STRANU) · S63 (UGRADITE MATICU M25 S UNUTARNJE STRANE) · S63 (NAMONTUJTE MATICI M25 NA VNITRNÍ STRANU) · S63 (NAMESTITE MATICO M25 NA NOTRANJO STRAN) · S63 (INSTALLERA MUTTER M25 PÅ INSIDAN) · S63 (M25 SOMUNU İÇ TARAFI TAKIN) · S63 (INSTALONI DADON M25 NĚ PĚŠĚN E BRENDŠHME) · S63 (УСТАНОВИТЕ ГАЙКУ М25 НА ВНУТРЕННЮЮ СТОРОНУ) · S63 (ZAMONTUJ NAKRETKĚ M25 OD WEWNĄTRZ) · S63 (SZERELJE FEL AZ M25-ÖS ANYÁT A BELSŐ OLDALRA)

PART	NO	QTY
[5F048	1
[5G047	1
	S74 M4X8	4
	M25 M4	4



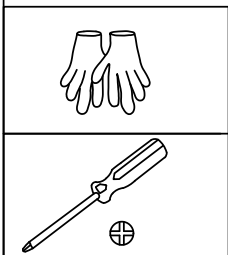



WRAP 5G047 WITH 5F048 · ENVUELVA 5G047 CON 5F048 · ENVOLVA 5G047 COM 5F048 · ENVELOPPEZ 5G047 AVEC 5F048 · UMWICKELN SIE 5G047 MIT 5F048 · TYAIETE TO 5G047 ME TO 5F048 · AVVOLGERE 5G047 CON 5F048 · OMOTAJTE 5G047 POMOCOU 5F048 · ZAMOTAJTE 5G047 S 5F048 · OMOTEJTE 5G047 POMOCI 5F048 · OVIJTE 5G047 S 5F048 · LINDA IN 5G047 MED 5F048 · 5G047'YI 5F048 ILE SARIN · MBESHITILLNI 5G047 ME 5F048 · OBERNITE 5G047 DETAL'YU 5F048 · OWIN 5G047 ZA POMOCU 5F048 · TEKERJE KÖRBE A 5G047-ET 5F048-CAL

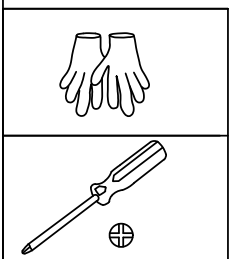
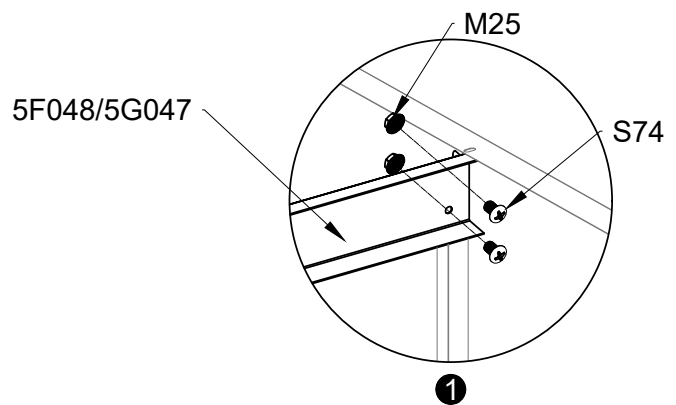
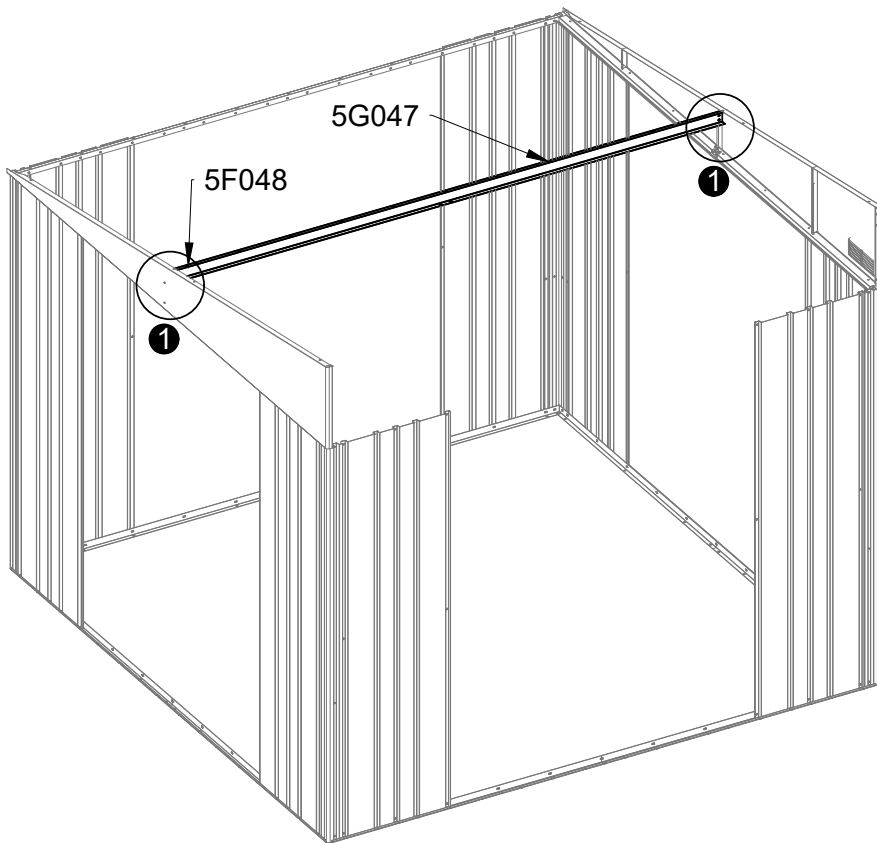

PART	NO	QTY
	S74	4
	M4X8	
	M25	4
	M4	



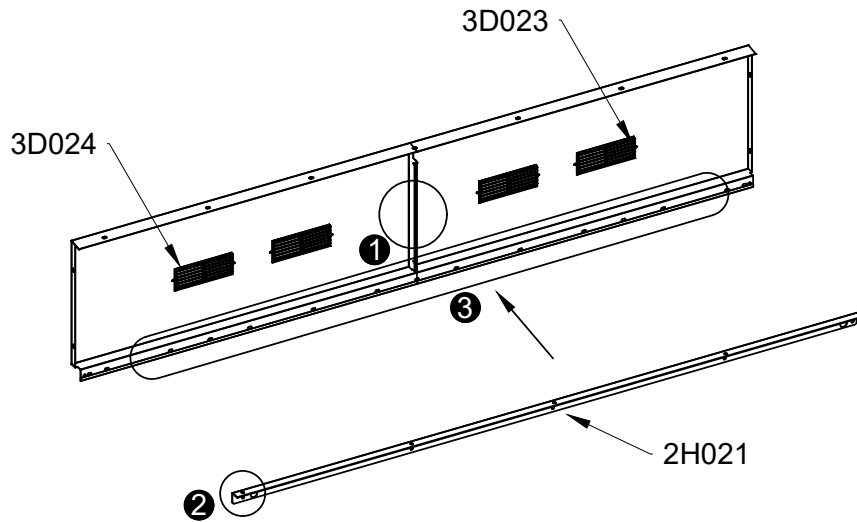
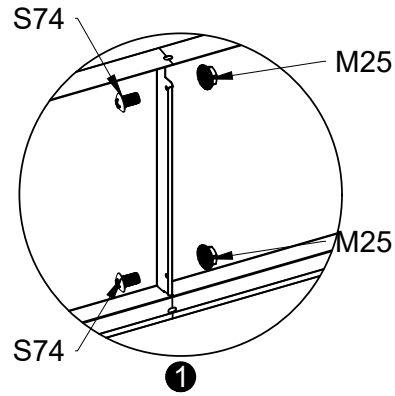

PART	NO	QTY
	3D023	1
	3D024	1
	2H021	1
	S74	8
	M4X8	
	M25	8
	M4	



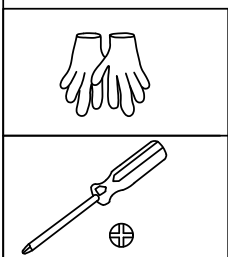
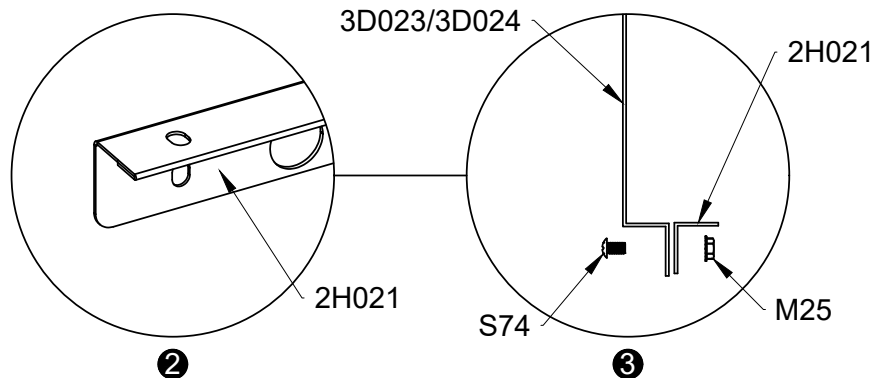



2H021 INSTALL IN THE CENTER · 2H021 INSTALAR EN EL CENTRO · 2H021 INSTALAR NO CENTRO · 2H021 INSTALLER AU CENTRE · 2H021 IN DER MITTE INSTALLIEREN · 2H021 ΤΟΠΟΘΕΤΗΣΤΕ ΣΤΟ ΚΕΝΤΡΟ · 2H021 INSTALLARE AL CENTRO · 2H021 NAINŠTALUJTE DO STŘEDU · 2H021 UGRADITE U SREDINU · 2H021 NAMONTUJTE DO STŘEDU · 2H021 NAMESTITE V SREDINO · 2H021 INSTALLERA I MITTEN · 2H021 MERKEZE MONTE EDIN · 2H021 INSTALONI NĚ QENDER · 2H021 VCTAHOBITE ПО ЦЕНТРУ · 2H021 ZAMONTUJ NA SRODKU · 2H021 SZERELJE KÖZÉPRE

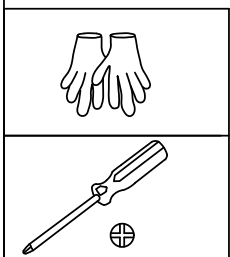
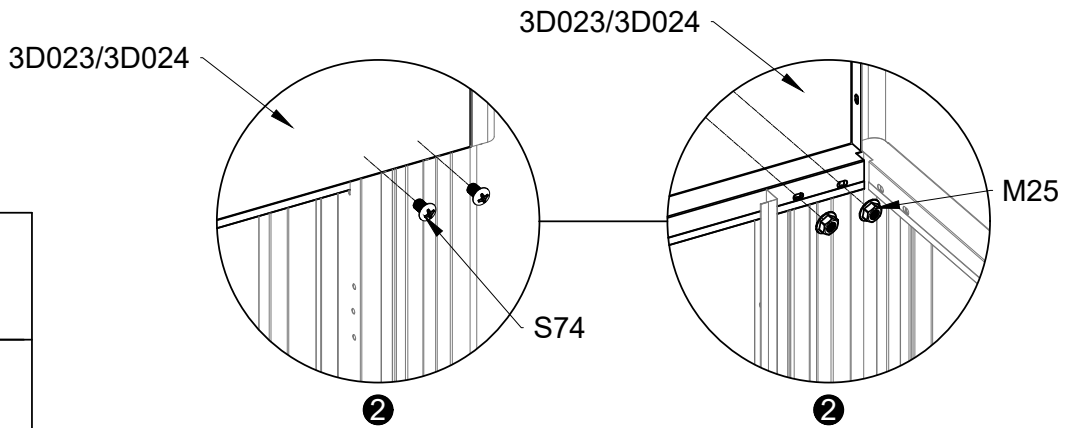
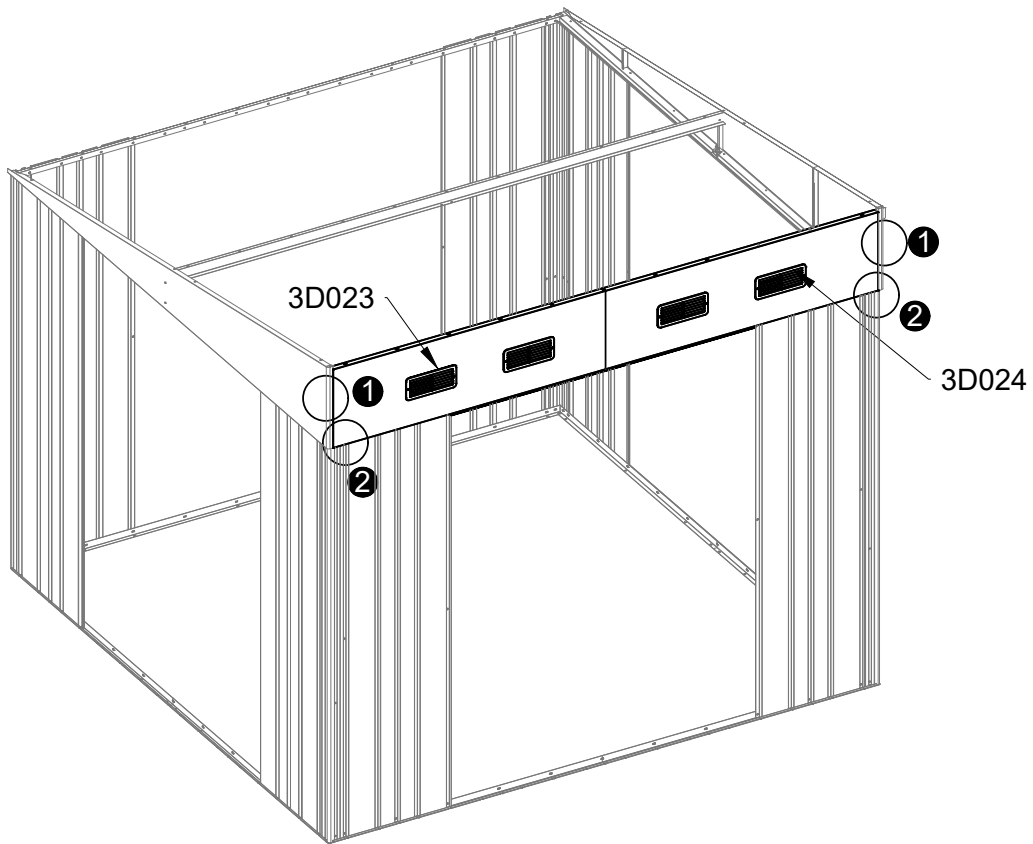
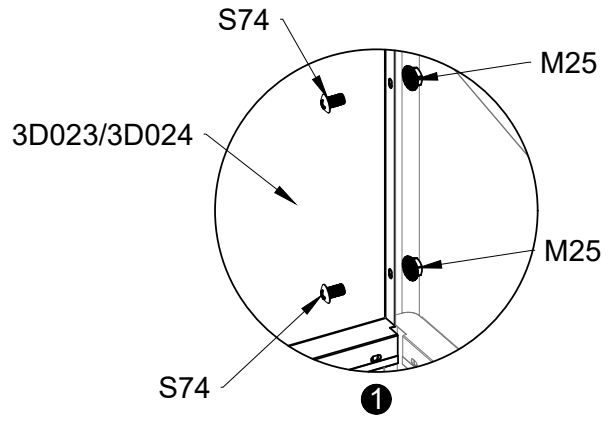



PART	NO	QTY
	S74	12
	M4X8	
	M25	12
	M4	



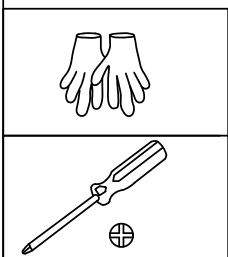
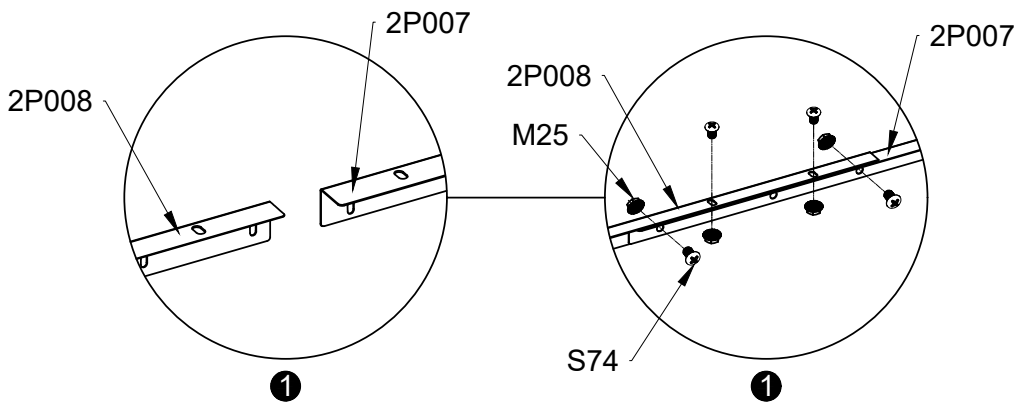
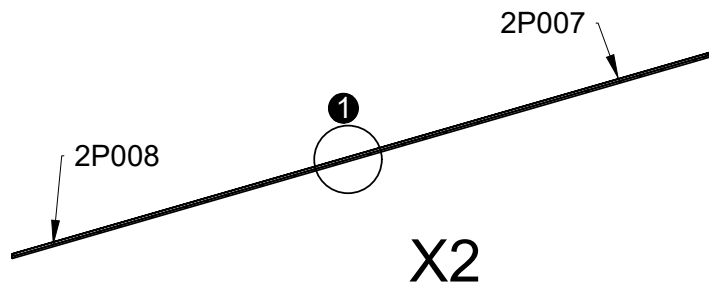



PART	NO	QTY
	2P007	2
	2P008	2
	S74 M4X8	8
	M25 M4	8

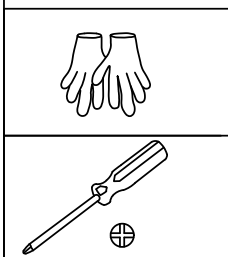
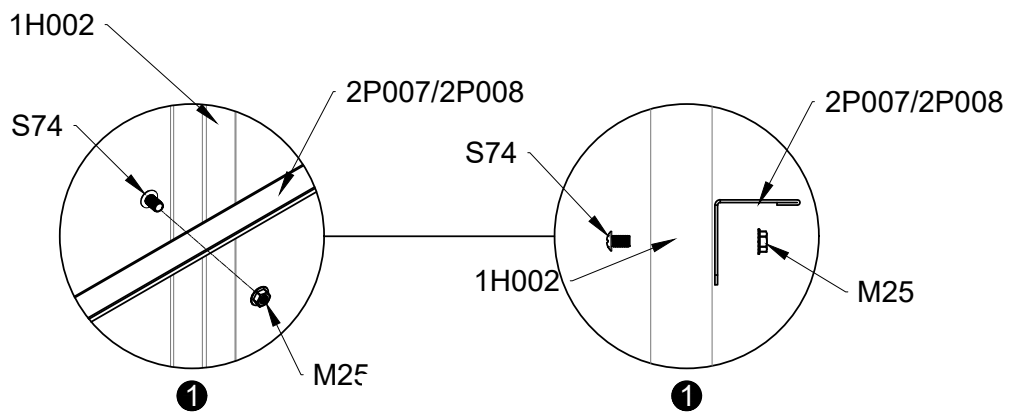
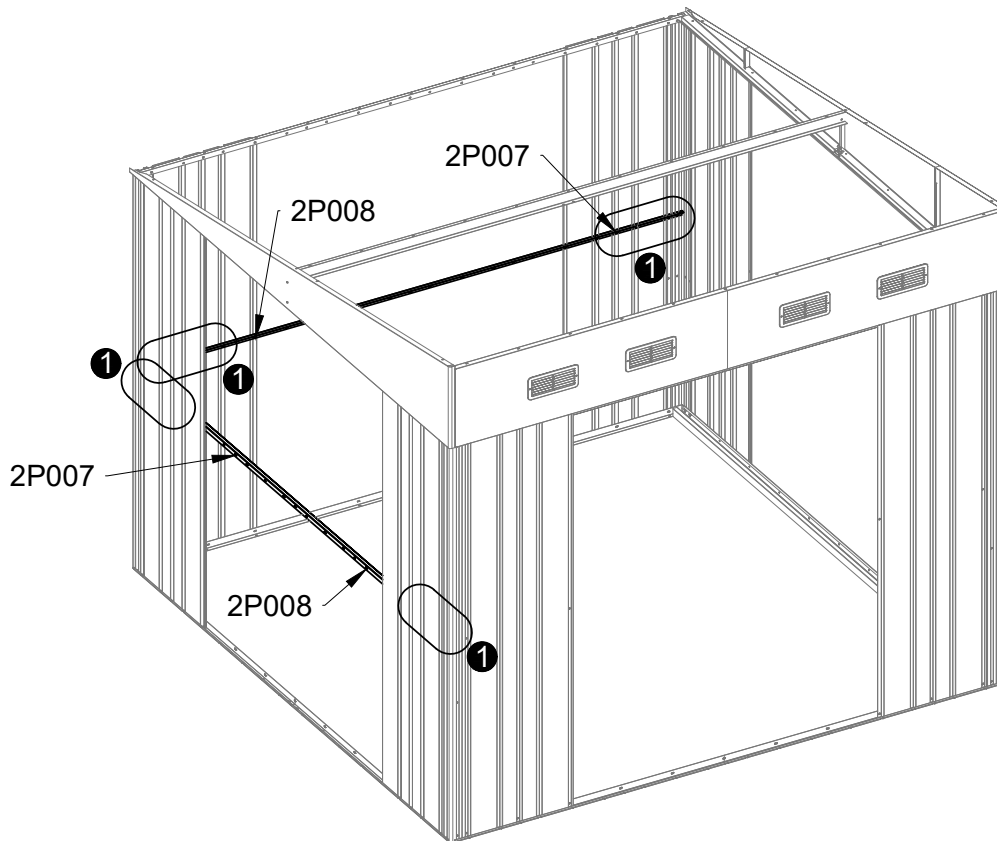

PART	NO	QTY
	S74	8
	M4X8	
	M25	8
	M4	



PART	NO	QTY
	2P018	1
	2P019	1
	S74	6
	M4X8	
	M25	6
	M4	

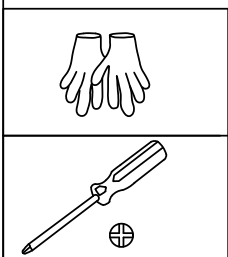
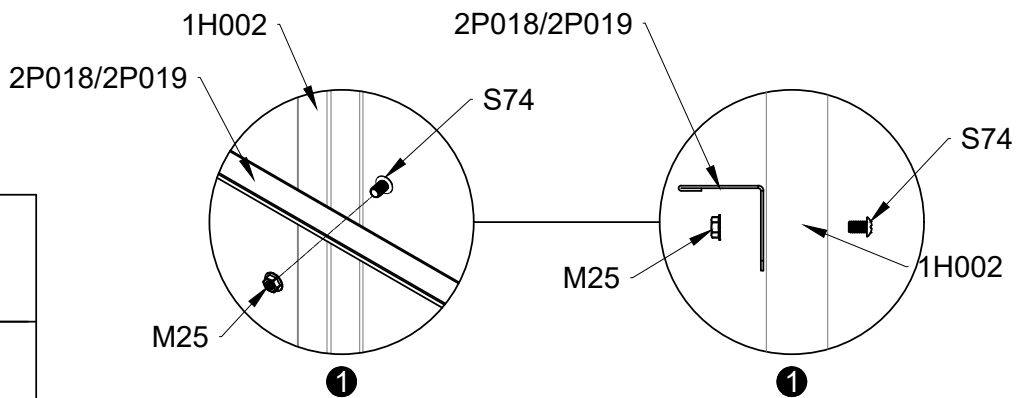
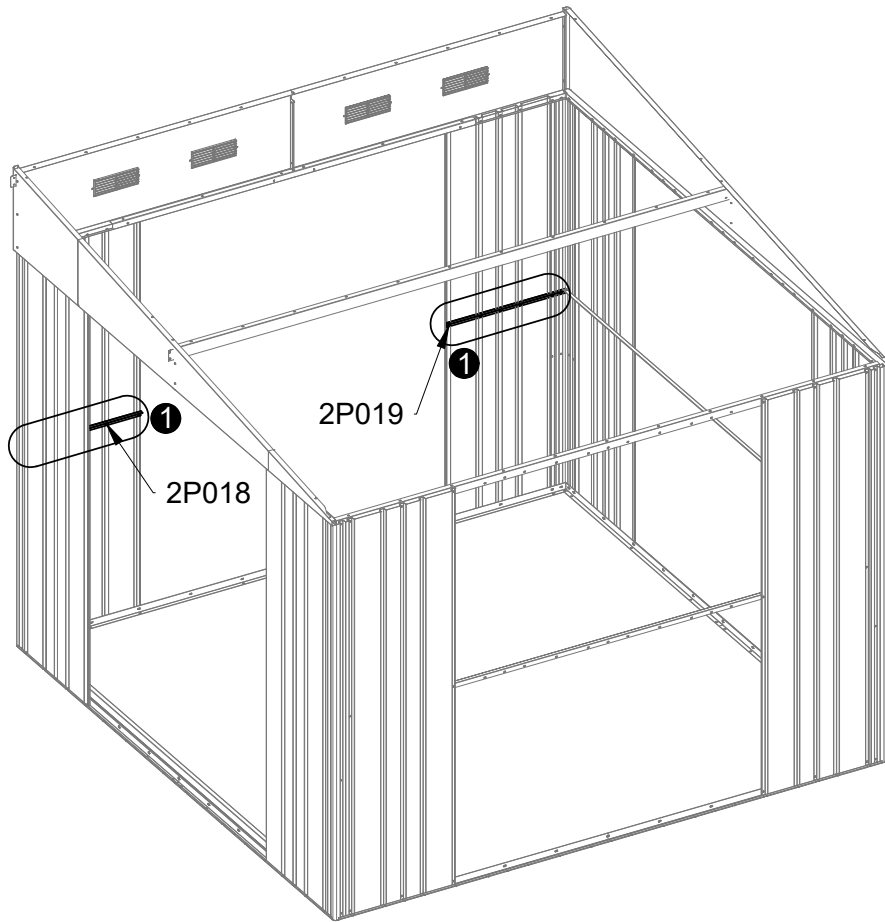



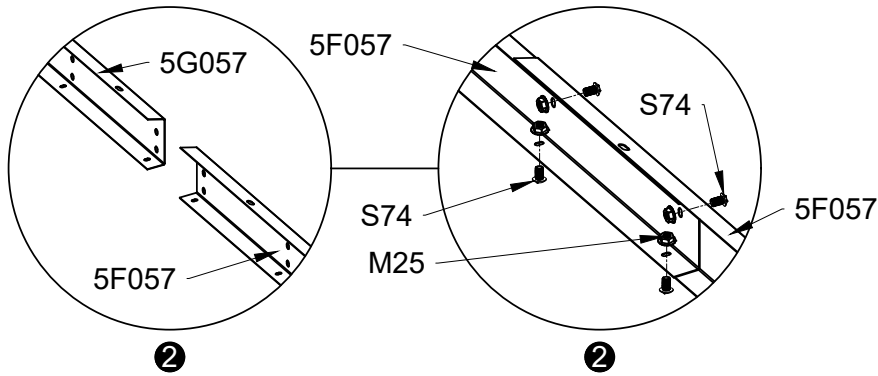
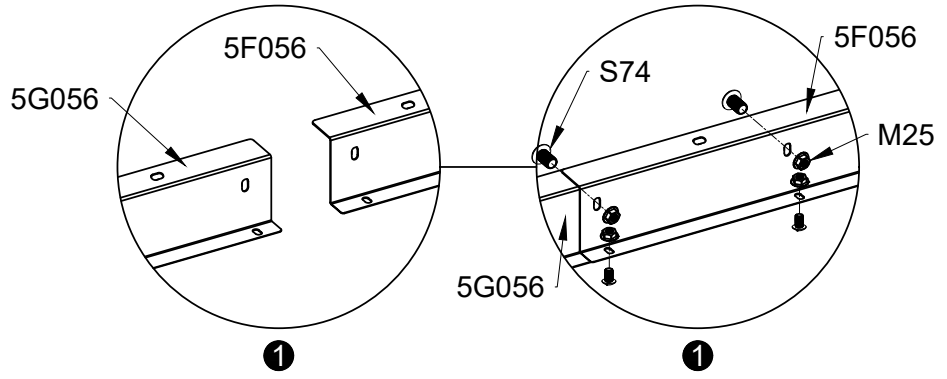

PART	NO	QTY
	5F056	1
	5F057	1
	5F058	1
	5G056	1
	5G057	1
	5G058	1
	S74 M4X8	6
	M25 M4	6

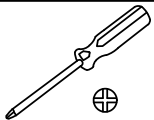
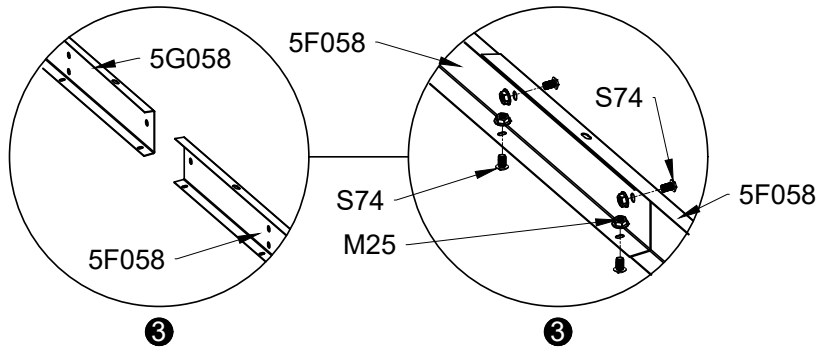
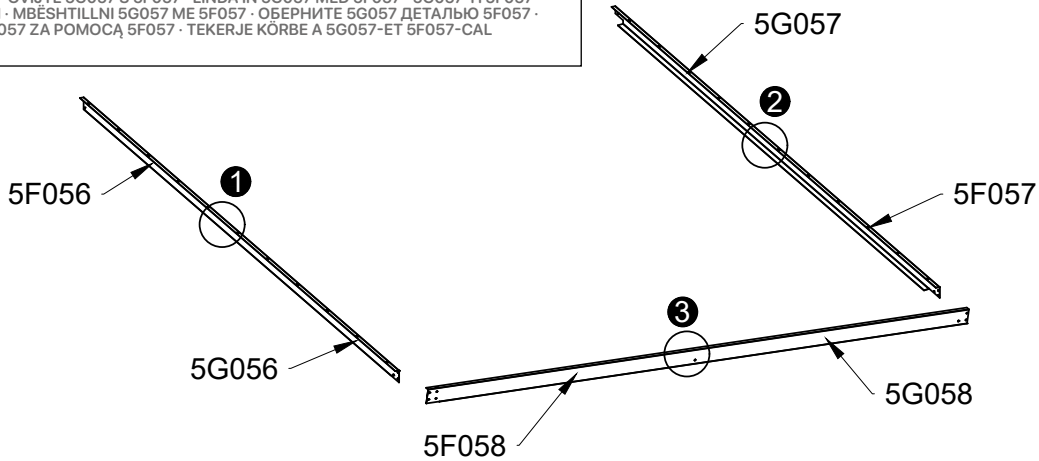

WRAP 5G057 WITH 5F057 · ENVUELVA 5G057 CON 5F057 · ENVOLVA 5G057 COM 5F057 · ENVELOPEZ 5G057 AVEC 5F057 · UMWICKELN SIE 5G057 MIT 5F057 · TYLIETE TO 5G057 ME TO 5F057 · AVVOLGERE 5G057 CON 5F057 · OMOTAJTE 5G057 POMOCOU 5F057 · ZAMOTAJTE 5G057 S 5F057 · OMOTEJTE 5G057 POMOCI 5F057 · OVIJTE 5G057 S 5F057 · LINDA IN 5G057 MED 5F057 · 5G057'YI 5F057 ILE SARIN · MBESH-TILLNI 5G057 ME 5F057 · OBERHITE 5G057 DETAL'YU 5F057 · OWIN 5G057 ZA POMOCU 5F057 · TEKERJE KÖRBE A 5G057-ET 5F057-CAL



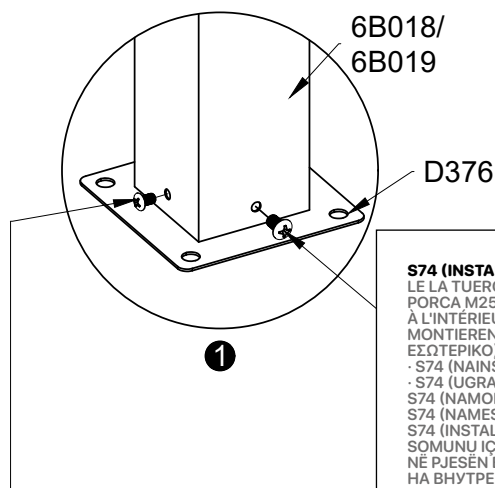
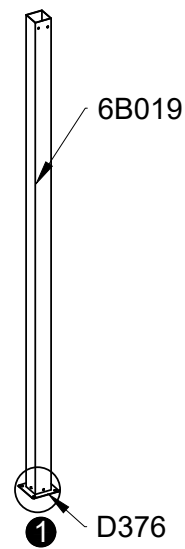
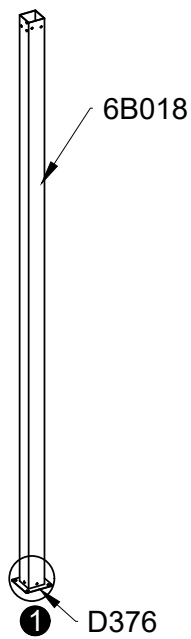

WRAP 5G058 WITH 5F058 · ENVUELVA 5G058 CON 5F058 · ENVOLVA 5G058 COM 5F058 · ENVELOPEZ 5G058 AVEC 5F058 · UMWICKELN SIE 5G058 MIT 5F058 · TYLIETE TO 5G058 ME TO 5F058 · AVVOLGERE 5G058 CON 5F058 · OMOTAJTE 5G058 POMOCOU 5F058 · ZAMOTAJTE 5G058 S 5F058 · OMOTEJTE 5G058 POMOCI 5F058 · OVIJTE 5G058 S 5F058 · LINDA IN 5G058 MED 5F058 · 5G058'YI 5F058 ILE SARIN · MBESH-TILLNI 5G058 ME 5F058 · OBERHITE 5G058 DETAL'YU 5F058 · OWIN 5G058 ZA POMOCU 5F058 · TEKERJE KÖRBE A 5G058-ET 5F058-CAL

PART	NO	QTY
	6B018	1
	6B019	1
	D376	2
	S74 M4X8	8
	M25 M4	8



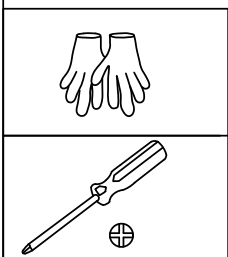

S74 (INSTALL NUT M25 ON THE INSIDE) · S74 (INSTALLE LA TUERCA M25 EN EL INTERIOR) · S74 (INSTALAR A PORCA M25 NO INTERIOR) · S74 (INSTALLER L'ÉCROU M25 À L'INTÉRIEUR) · S74 (MUTTER M25 AUF DER INNENSEITE MONTIEREN) · S74 (ΤΟΠΟΘΕΤΗΣΤΕ ΤΟ ΠΑΞΙΜΑΔΙ Μ25 ΣΤΟ ΕΞΩΤΕΡΙΚΟ) · S74 (INSTALLARE IL DADO M25 ALL'INTERNO) · S74 (NAINSTALUJTE MATICU M25 NA VNUTORNŮ STRANU) · S74 (UGRADITE MATICU M25 S UNUTARNJE STRANE) · S74 (NAMONTUJTE MATICI M25 NA VNITRNÍ STRANU) · S74 (NAMESTITE MATICO M25 NA NOTRANJO STRAN) · S74 (INSTALLERA MUTTER M25 PÅ INSIDAN) · S74 (M25 SOMUNU IC TARAFÁ TAKIN) · S74 (INSTALONI DADON M25 NĚ P.JESĚNĚ BŘENDSHME) · S74 (УСТАHOВИТЕ ГАЙКУ М25 НА БИУПРЕДНІЮ СТОРОНУ) · S74 (ZAMONTUJ NAKRĚTKĚ M25 OD WEWNĄTRZ) · S74 (SZERELJE FEL AZ M25-ÖS ANYÁT A BELSŐ OLDALRA)

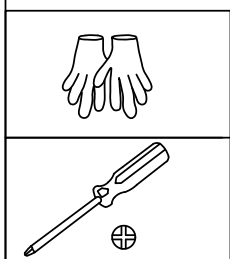
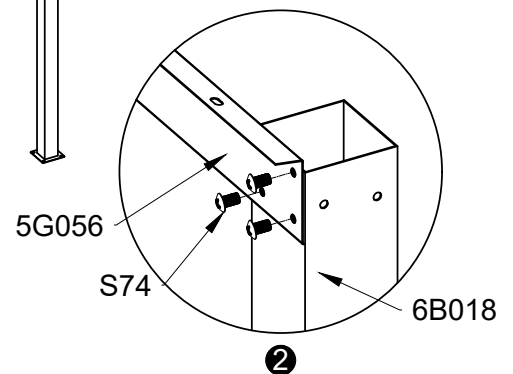
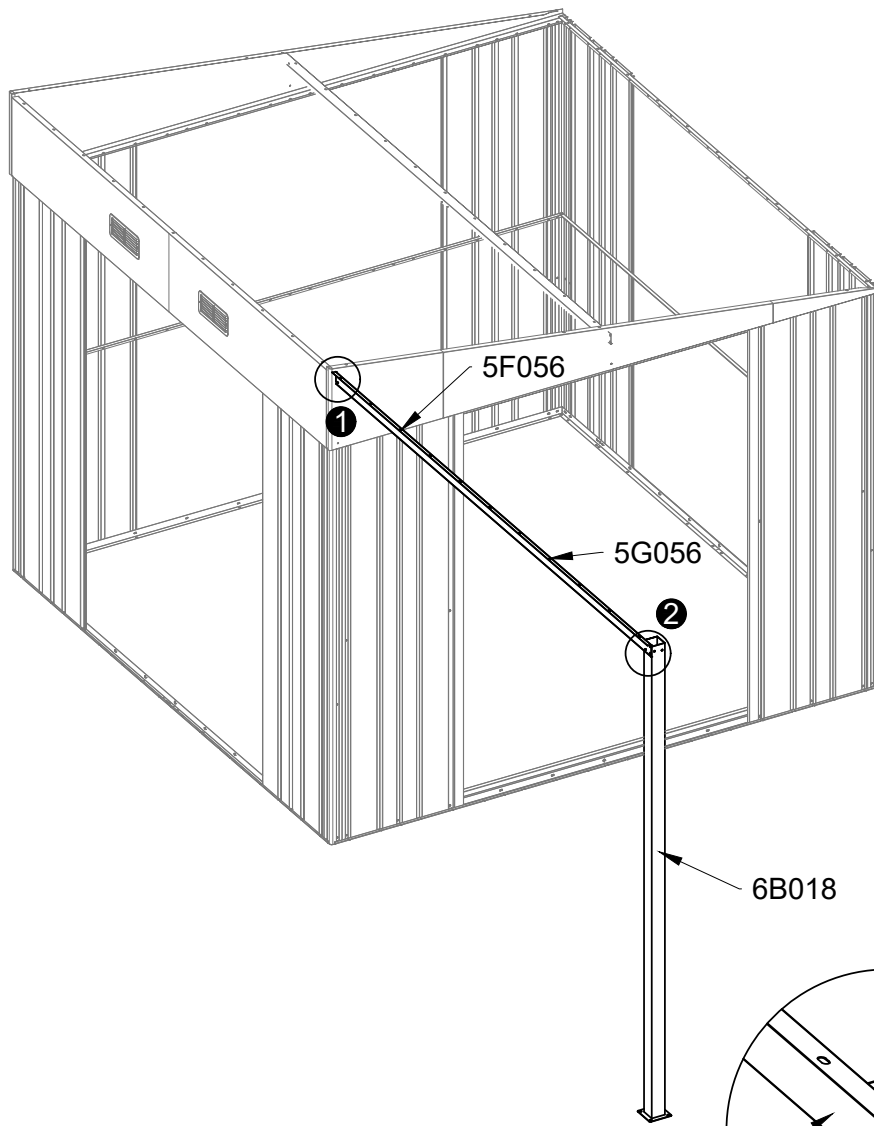
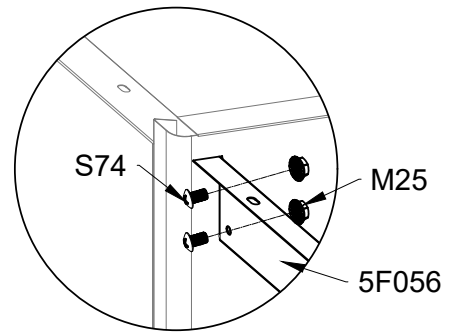

PART	NO	QTY
	S74	5
	M4X8	
	M25	2
	M4	



PART	NO	QTY
	S74	8
	M4X8	
	M25	1
	M4	

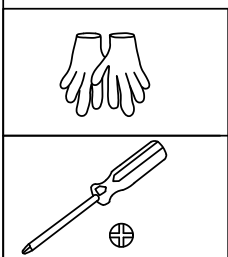
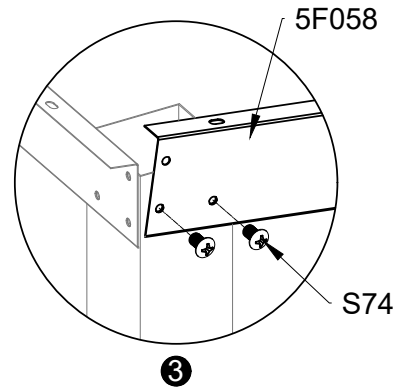
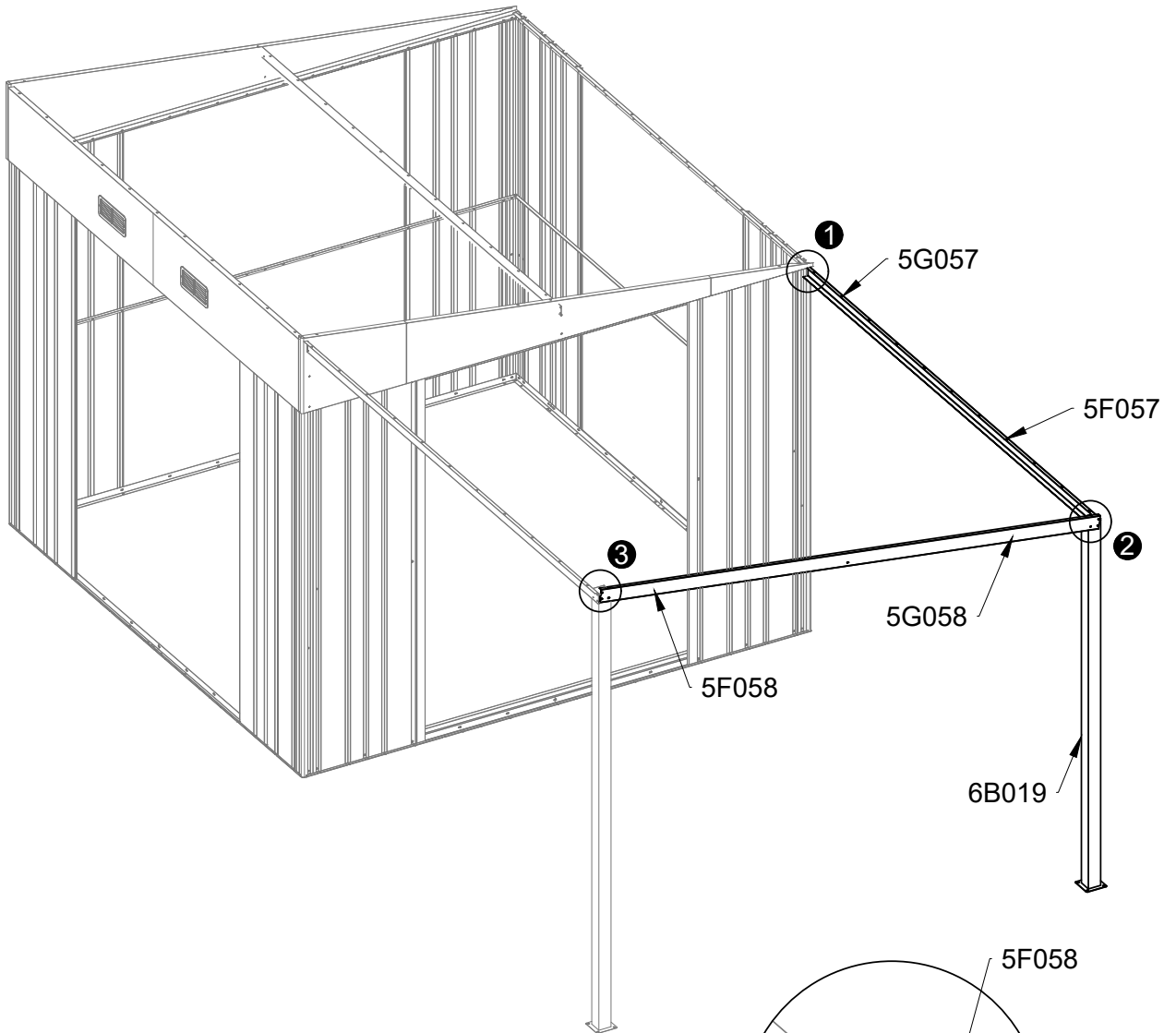
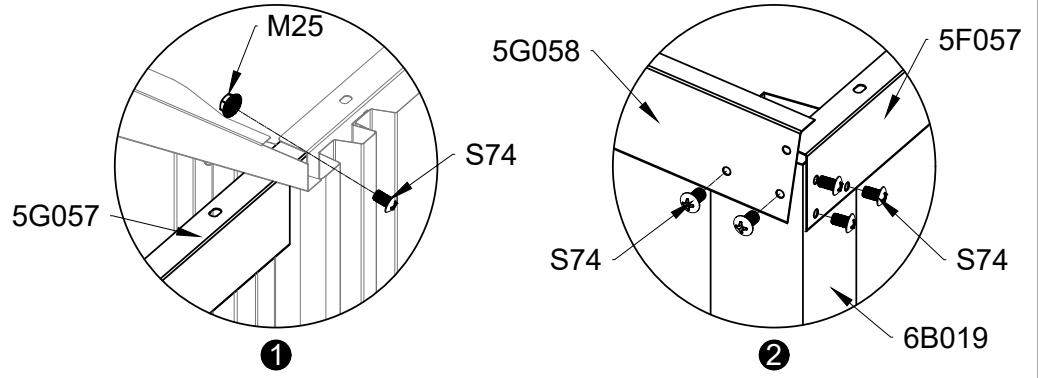



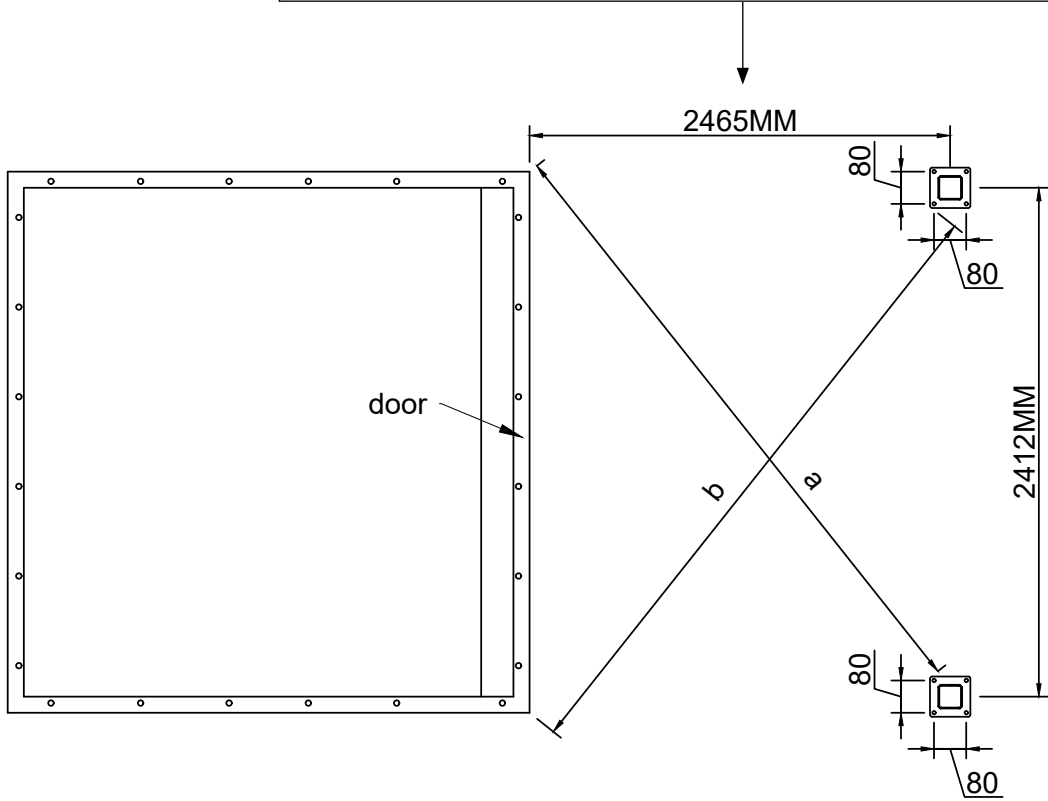

PART	NO	QTY
	S69	8

THE SIZE CAN BE ADJUSTED ACCORDING TO THE ACTUAL SITUATION · EL TAMAÑO SE PUEDE AJUSTAR SEGÚN LA SITUACIÓN REAL · O TAMANHO PODE SER AJUSTADO DE ACORDO COM A SITUAÇÃO REAL · LA TAILLE PEUT ÊTRE AJUSTÉE EN FONCTION DE LA SITUATION RÉELLE · DIE GRÖSSE KANN JE NACH TATSÄCHLICHER SITUATION ANGEPA SST WERDEN · ΤΟ ΜΕΓΕΘΟΣ ΜΠΟΡΕΙ ΝΑ ΠΡΟΣΑΡΜΟΣΤΕΙ ΑΝΑΛΟΓΑ ΜΕ ΤΗΝ ΠΡΑΓΜΑΤΙΚΗ ΚΑΤΑΣΤΑΣΗ · LE DIMENSIONI POSSONO ESSERE REGOLATE IN BASE ALLA SITUAZIONE REALE · VEĽKOSŤ JE MOŽNÉ UPRAVIŤ PODĽA AKTUÁLNEJ SITUÁCIE · VEĽIČINA SE MOŽE PRILAGODITI PREMA STVARNOJ SITUACIJI · VEĽIKOSŤ LZE UPRAVIŤ PODĽA AKTUÁLNEJ SITUACE · VEĽIKOSŤ JE MOGOĆE PRILAGODITI GLEDE NA DEJANSKO STANJE · STORLEKEN KAN JUSTERAS EFTER DEN FAKTISKA SITUATIONEN · BOYUT, FIILI DURUMA GÖRE AYARLANABILIR · MADHĒSIA MUND TĒ RREGULLOHEŢ SIPAS SITUATĒS AKTUALE · РАЗМЕР МОЖЕТ БЫТЬ СКОРРЕКТИРОВАН В ЗАВИСИМОСТИ ОТ РЕАЛЬНОЙ СИТУАЦИИ · ROZMIAR MOŻNA DOSTOSOWAĆ DO RZECZYWISTEJ SYTUACJI · A MÉRĒT A TĒNYLEGES HELYZETNEK MEGFELELŐEN ÁLLÍTHATÓ

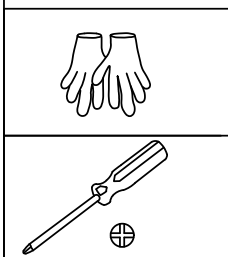
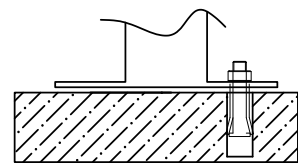
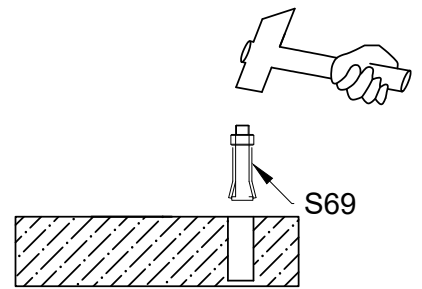
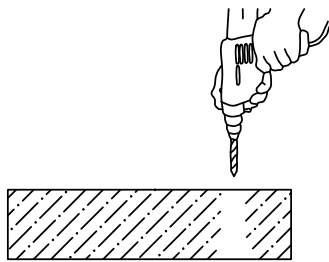
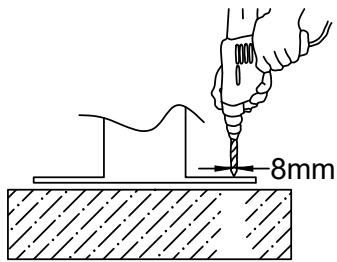

Ⓐ = Ⓑ



PART	NO	QTY
	5F059	1
	5G059	1
	S74	7
	M4X8	
	M25	7
	M4	

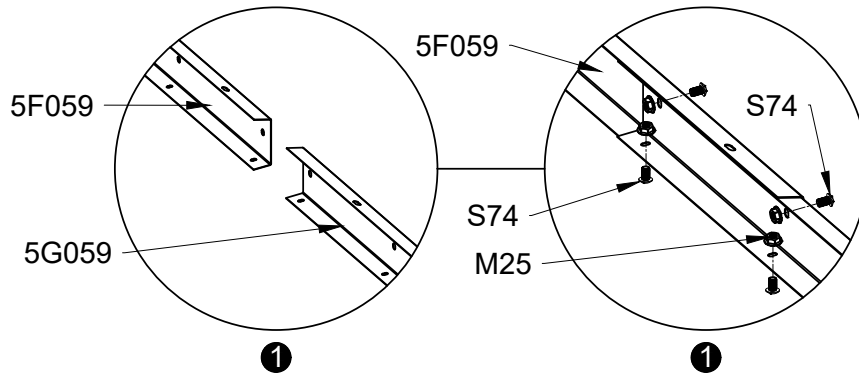

WRAP 5G059 WITH 5F059 · ENVUELVA 5G059 CON 5F059 · ENVOLVA 5G059 COM 5F059 · ENVELOPPEZ 5G059 AVEC 5F059 · UMWICKELN SIE 5G059 MIT 5F059 · TYLIETE TO 5G059 ME TO 5F059 · AVVOLGERE 5G059 CON 5F059 · OMOTAJTE 5G059 POMOCOU 5F059 · ZAMOTAJTE 5G059 S 5F059 · OMOTEJTE 5G059 POMOCÍ 5F059 · OVIJTE 5G059 Š 5F059 · LINDA IN 5G059 MED 5F059 · 5G059'YI 5F059 ILE SARIN · MBĚSH-TILLNI 5G059 ME 5F059 · OBERNITE 5G059 DETAL'YU 5F059 · OWIN 5G059 ZA POMOCĄ 5F059 · TEKERJE KÖRBE A 5G059-ET 5F059-CAL

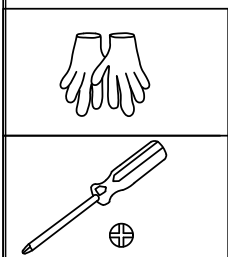
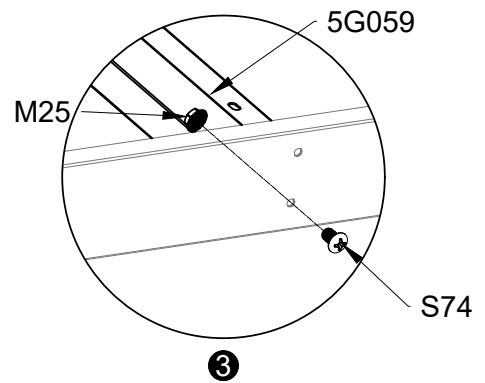
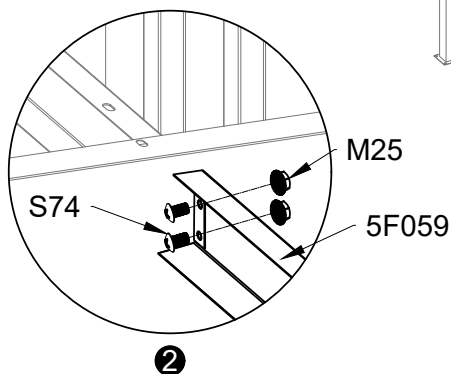
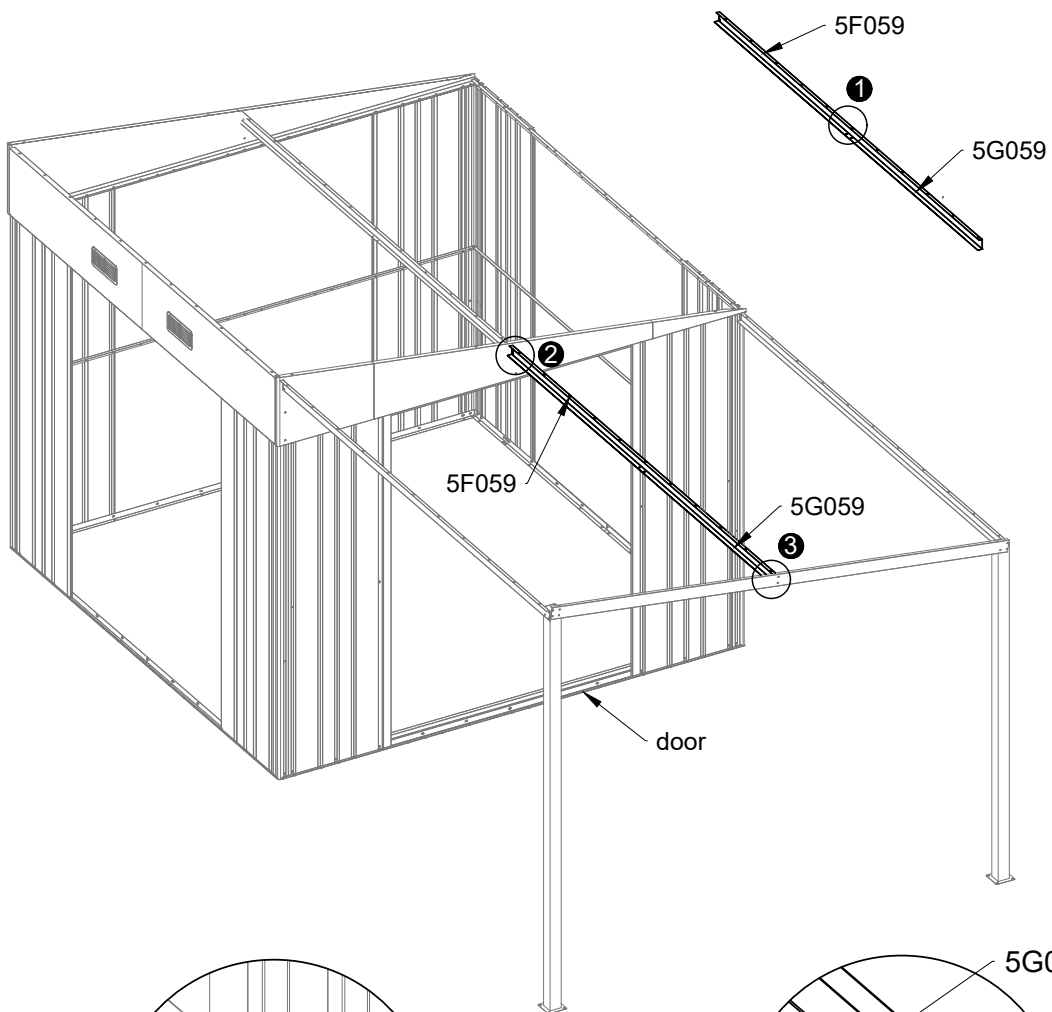



NEXT, WE WILL SELECT THE WINDOW POSITION. YOU CAN INSTALL IT IN ANY OF THE PANELS INDICATED IN THE FOLLOWING DIAGRAM - A CONTINUACIÓN, SELECCIONAREMOS LA POSICIÓN DE LA VENTANA. PUEDE INSTALARLA EN CUALQUIERA DE LOS PANELES SEÑALADOS EN EL SIGUIENTE DIAGRAMA - EM SEGUIDA, SELECCIONAREMOS A POSIÇÃO DA JANELA. PODE INSTALÁ-LA EM QUALQUER UM DOS PAINÉIS ASSINALADOS NO SEGUINTE DIAGRAMA - ENSUITE, NOUS SELECTIONNERONS L'EMPLACEMENT DE LA FENÊTRE. VOUS POUVEZ L'INSTALLER SUR N'IMPORTE QUEL PANNEAU INDICUÉ DANS LE DIAGRAMME SUIVANT - ALS NÄCHSTES WÄHLEN WIR DIE FENSTERPOSITION AUS. SIE KÖNNEN ES AN JEDEM DER GEKENNZEICHNETEN PANELE IM FOLGENDEN DIAGRAMM INSTALLIEREN - ΣΤΗ ΣΥΝΕΧΕΙΑ, ΘΑ ΕΠΙΛΕΞΟΥΜΕ ΤΗ ΘΕΣΗ ΤΟΥ ΠΑΡΑΘΥΡΟΥ. ΜΠΟΡΕΙΤΕ ΝΑ ΤΟ ΕΓΚΑΤΑΣΤΗΣΕΤΕ ΣΕ ΟΠΟΙΟΔΗΠΟΤΕ ΑΠΟ ΤΑ ΠΛΑΙΣΙΑ ΠΟΥ ΥΠΟΔΕΙΚΝΥΟΝΤΑΙ ΣΤΟ ΑΚΟΛΟΥΘΟ ΔΙΑΓΡΑΜΜΑ - SUCCESSIVAMENTE, SELEZIONEREMO LA POSIZIONE DELLA FINESTRA. È POSSIBILE INSTALLARLA IN UNO QUALSIASI DEI PANNELLI INDICATI NEL SEGUENTE DIAGRAMMA - DALEJ ZVOLÍME POLOHU OKNA. MŮŽETE HO NAINSTALOVAT DO KTERÉHOKOLVEK Z PANELOV VYZNAČENÝCH V NÁSLEDUJÍCÍM DIAGRAMU - ZATÍM ČEMO ODABRATI POLOŽAJ PROZORA. MOŽETE GA INSTALIRATI NA BILO KOJU OD PLOČA OZNAČENIH NA SLJEDEĆEM DIJAGRAMU - DÁLE ZVOLÍME POLOHU OKNA. MŮŽETE JEJ NAINSTALOVAT DO KTERÉHOKOLI Z PANELOV VYZNAČENÝCH V NÁSLEDUJÍCÍM DIAGRAMU - NATO BOMO IZBRALI POLOŽAJ OKNA. NAMESTITE GA LAHKO NA KATERO KOLI OD PLOŠČ, OZNAČENIH NA NASLEDNJEM DIAGRAMU - DÁREFTER VÁLJER VI FÖNSTERPOSITIONEN. DU KAN INSTALLERA DEN PÅ VILKEN SOM HELST AV DE MARKERADE PANELERNA I FÖLJANDE DIAGRAM - ARDINDAN, PENCERE KONUMUNU SEÇECEĞİZ. AŞAĞIDAKI DIYAGRAMDA BELİRTİLEN PANELLERDEN HERHANGİ BİRINE MONTE EDEBİLİRSİNİZ. MÊ PAS, DO TÊ ZGJEDHIM POZICIONIN E DRITARES. MUND TA INSTALONI NĚ CILINDO NGA PANELET E SHĚNUARA NĚ DIAGRAMIN E MĚPOŠTĚM - ДАЛЕЕ МЫ ВЫБЕРЕМ ПОЛОЖЕНИЕ ОКНА. ВЫ МОЖЕТЕ УСТАНОВИТЬ ЕГО НА ЛЮБУЮ ИЗ ПАНЕЛЕЙ, УКАЗАННЫХ НА СЛЕДУЮЩЕЙ СХЕМЕ - NASTĚPNIE WYBIEREMY POZYCJĘ OKNA. MOŻNA JE ZAINSTALOWAĆ NA DOWOLNYM Z PANELEI WSKAZANYCH NA PONIŻSZYM SCHEMACIE - EZUTÁN KIVÁLSZTJUK AZ ABLAK POZÍCIÓJÁT. A KÖVETKEZŐ ÁBRÁN JELZETT PANELEK BARMELYIKÉRE FELSZERELHETI.

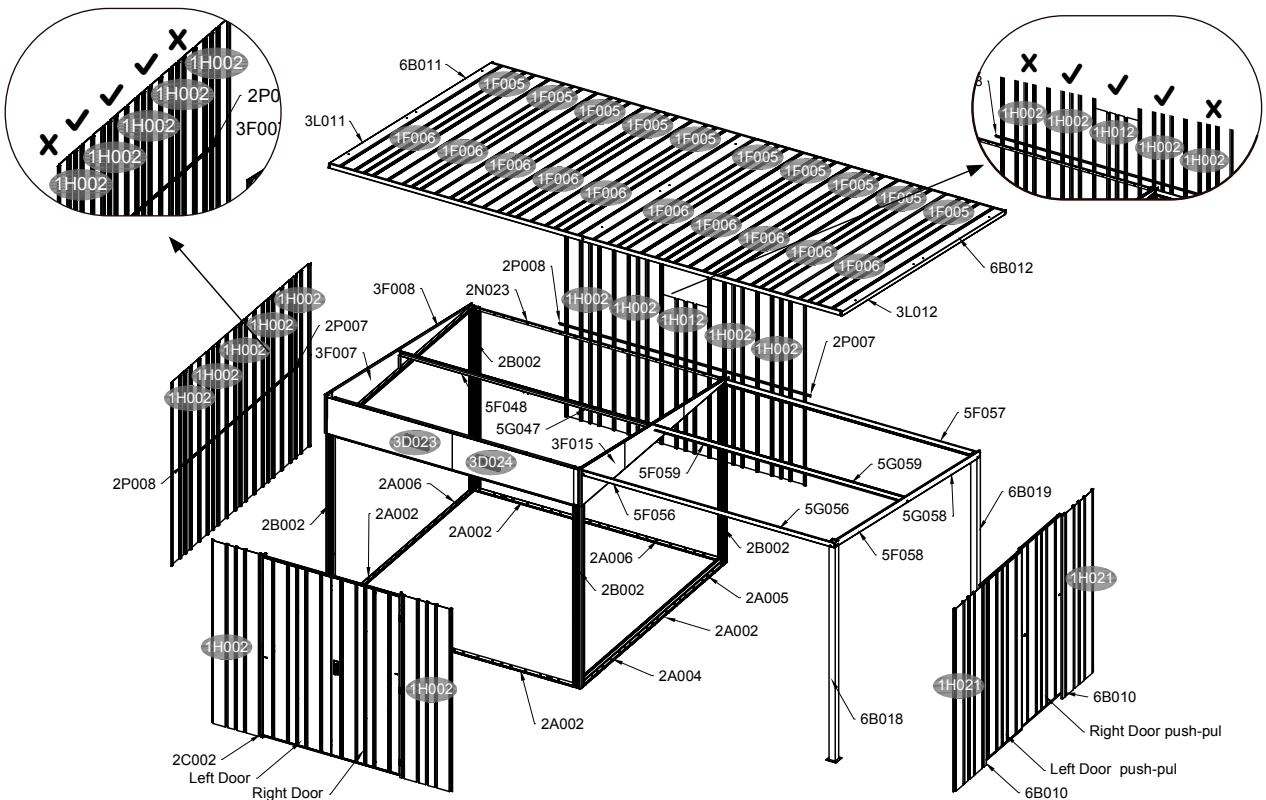



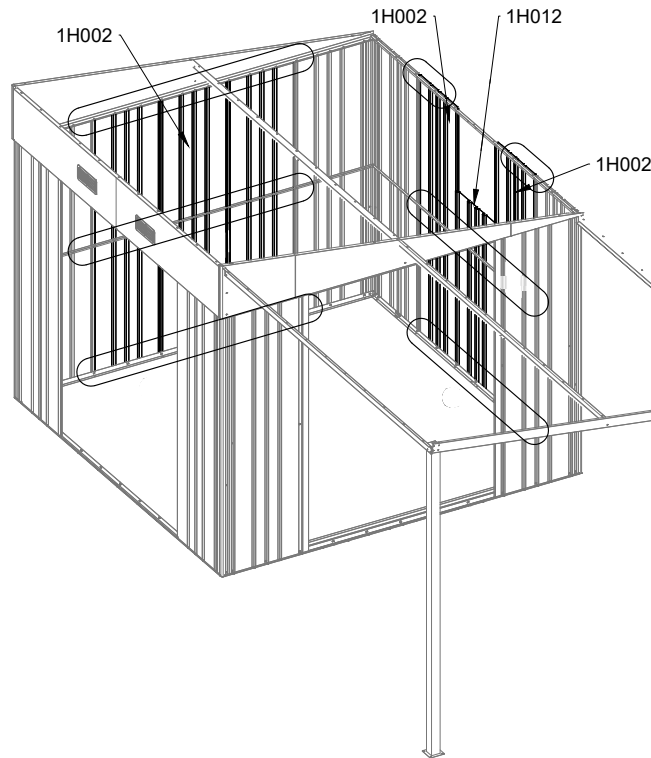

ONCE YOU SELECT THE WINDOW POSITION, MAKE SURE YOU USE PANEL 1H012 AS ITS BASE · UNA VEZ SELECCIONADA LA POSICIÓN DE LA VENTANA, ASEGÚRESE DE UTILIZAR EL PANEL 1H012 COMO BASE DE LA MISMA · UMA VEZ SELECCIONADA A POSIÇÃO DA JANELA, CERTIFIQUE-SE DE UTILIZAR O PAINEL 1H012 COMO BASE DA MESMA · UNE FOIS L'EMPLACEMENT DE LA FENÊTRE CHOISI, ASSUREZ-VOUS D'UTILISER LE PANNEAU 1H012 COMME BASE DE CELLE-CI · SOBALD DIE FENSTERPOSITION AUSGEWÄHLT IST, ACHTEN SIE DARAUF, DAS PANEEL 1H012 ALS BASIS ZU VERWENDEN · ΑΦΟΥ ΕΠΙΛΕΞΕΤΕ ΤΗ ΘΕΣΗ ΤΟΥ ΠΑΡΑΘΥΡΟΥ, ΒΕΒΑΙΩΘΕΙΤΕ ΟΤΙ ΧΡΗΣΙΜΟΠΟΙΕΙΤΕ ΤΟ ΠΛΑΙΣΙΟ 1H012 ΩΣ ΒΑΣΗ ΤΟΥ · UNA VOLTA SELEZIONATA LA POSIZIONE DELLA FINESTRA, ASSICURARSI DI UTILIZZARE IL PANNELLO 1H012 COME BASE DELLA STESSA · PO VÝBERE POLOHY OKNA NEZABUDNITE POUŽIT PANEĽ 1H012 AKO JEHO ZÁKLADŇU · NAKON ŠTO ODABERETE POLOŽAJ PROZORA, SVAKAKO KORISTITE PLOČU 1H012 KAO NJEZINU BAZU · PO VÝBERU POLOHY OKNA NEZAPOMENITE POUŽIT PANEĽ 1H012 JAKO JEHO ZÁKLADŇU · KO IZBERETE POLOŽAJ OKNA, NE POZABITE UPORABITI PLOŠČE 1H012 KOT NJENO PODLAGO · NÄR FÖNSTERPOSITIONEN HAR VALTS, SE TILL ATT ANVÄNDA PANEĽ 1H012 SOM BAS FÖR DENNA · PENCERE KONUMU SEÇILDİKTEN SONRA, 1H012 PANELİNİ TABAN OLARAK KULLANDIĞINIZDAN EMİN OLUN · PASI TĒ KENI ZĢGJEDHUR POZICIONIN E DRITARES, SIGUROHUNI QĒ TĒ PĒRDNRI PANELIN 1H012 SI BAZĒ TĒ SAJ · ВІБРАВ ПОЛОЖЕННЯ ОКНА, ОБЯЗАТЕЛЬНО ІСПОЛЬЗУЙТЕ ПАНЕЛЬ 1H012 В КАЧЕСТВЕ ЕГО ОСНОВАНИЯ · PO WYBRANIU POZYCJI OKNA NALEŻY UŻYC PANEĽU 1H012 JAKO JEHO PODSTAWY · AZ ABLAK POZÍCIÓJÁNAK KIVÁLASZTÁSA UTÁN ÜGYELJEN ARRÁ, HOGY AZ 1H012-ES PANEĽT HASZNÁLJA ALAPKÉNT.



IN THE MANUAL, THE STEPS ARE SHOWN FOR THIS POSITION; PLEASE NOTE THAT IF YOU HAVE CHOSEN A DIFFERENT LOCATION, YOU MUST ADAPT THE INSTRUCTIONS ACCORDINGLY · EN EL MANUAL LOS PASOS APARECEN EJEMPLIFICADOS CON ESTA POSICIÓN, TENGA EN CUENTA QUE SI HA DECIDIDO UBICAR LA VENTANA EN OTRO DE LOS PUNTOS POSIBLES DEBE ADAPTAR LAS INSTRUCCIONES A LA POSICIÓN ELEGIDA · NO MANUAL, OS PASSOS SÃO EXEMPLIFICADOS COM ESTA POSIÇÃO; TENHA EM CONTA QUE, SE DECIDIU COLOCAR A JANELA NOUTRO DOS PONTOS POSSÍVEIS, DEVE ADAPTAR AS INSTRUÇÕES À POSIÇÃO ESCOLHIDA · DANS LE MANUEL, LES ÉTAPES SONT ILLUSTRÉES POUR CETTE POSITION; NOTEZ QUE SI VOUS AVEZ CHOISI UN AUTRE EMBLACEMENT, VOUS DEVREZ ADAPTER LES INSTRUCTIONS EN CONSÉQUENCE · IM HANDBUCH WERDEN DIE SCHRITTE FÜR DIESE POSITION BEISPIELHAFT DARGESTELLT; BITTE BEACHTEN SIE, DASS SIE DIE ANWEISUNGEN ENTSPRECHEND ANPASSEN MÜSSEN, FALLS SIE DAS FENSTER AN EINER ANDEREN STELLE POSITIONIEREN · ΣΤΟ ΕΓΧΕΙΡΙΔΙΟ, ΤΑ ΒΗΜΑΤΑ ΠΑΡΟΥΣΙΑΖΟΝΤΑΙ ΓΙΑ ΑΥΤΗΝ ΤΗ ΘΕΣΗ. ΛΑΒΕΤΕ ΥΠΟΨΗ ΟΤΙ ΕΑΝ ΕΧΕΤΕ ΕΠΙΛΕΞΕΙ ΝΑ ΤΟΠΟΘΕΤΗΣΕΤΕ ΤΟ ΠΑΡΑΘΥΡΟ ΣΕ ΑΛΛΟ ΣΗΜΕΙΟ, ΠΡΕΠΕΙ ΝΑ ΠΡΟΣΑΡΜΟΣΕΤΕ ΤΙΣ ΟΔΗΓΙΕΣ ΣΤΗΝ ΕΠΙΛΕΓΜΕΝΗ ΘΕΣΗ · NEL MANUALE I PASSAGGI SONO ILLUSTRATI PER QUESTA POSIZIONE; SI PREGA DI NOTARE CHE SE SI È DECISO DI POSIZIONARE LA FINESTRA IN UN ALTRO DEI PUNTI POSSIBILI, È NECESSARIO ADATTARE LE ISTRUZIONI ALLA POSIZIONE SCELTA · V NÁVODE SÚ KROKY ZNÁZORNENÉ PRE TÚTO POLOHU; UPOZORŇUJEME, ŽE AK STE SA ROZHODLI UMÍSTNIT OKNO NA INÉ MIESTO, MUSÍTE POKYNY PRÍSPÔSOBIŤ ZVOLENEJ POLOHE · U PRÍRUČNIKU SU KORACI PRIKAZANI ZA OVAJ POLOŽAJ; IMAJTE NA UMU DA AKO STE ODLUČILI PROZOR POSTAVITI NA DRUGO MJEŠTO, UPUTE MORATE PRILAGODITI ODABRANOM POLOŽAJU · V NÁVODU JSOU KROKY ZNÁZORNĚNY PRO TUTO POLOHU; UPOZORŇUJEME, ŽE POKUD JSTE SE ROZHODLI UMÍSTIT OKNO NA JINÉ MÍSTO, MUSÍTE POKYNY PŘÍZPŮSOBIT ZVOLENÉ POLOZE · V PRIROČNIKU SO KORAKI PRIKAZANI ZA TA POLOŽAJ; UPOŠTEVAJTE, DA ČE STE SE ODLÓČILI OKNO POSTAVITI NA DRUGO MESTO, MORATE NAVODILA PRILAGODITI IZBRANEMU POLOŽAJU · I MANUALEN VISAS STEGEN FÖR DENNA POSITION; OBSERVERA OTI OM DU HAR VALT ATT PLACERA FÖNSTRET PÅ EN ANNAN PLATS MÅSTE DU ANPASSA INSTRUKTIONERNA EFTER DEN VALDA POSITIONEN · KILAVUZDAKI ADIMLAR BU KONUM İÇİN ÖRNEKLENDİRİLMİŞTİR; PENCEREYİ DİĞER OLASI NOKTALARDAN BİRİNE YERLEŞTİRMEYE KARAR VERDİYSENİZ, TALIMATLARI SEÇİLEN KONUMA GÖRE UYARLAMANIZ GEREKTİĞİNİ LÜTFEN UNUTMAYIN · NĒ MANUAL, HAPAT JANĚ ILUSTRUAR PĚR KĚTĚ POZICION; KINI PARASYSH SE NĚŠE KENI VENDOSUR TA VENDOSNI DRITAREN NĚ NJĚ NGA RİKAT E TJERA TĚ MUNDŠHME, DUHET T'İ PĚRŠHTATNI UDHĚZIMET SIPAS POZICIONIT TĚ ZĢGJEDHUR · В РУКОВОДСТВЕ ШАГИ ПОКАЗАНЫ НА ПРИМЕРЕ ЭТОГО ПОЛОЖЕНИЯ; УЧТИТЕ, ЧТО ЕСЛИ ВЫ РЕШИЛИ РАСПОЛОЖИТЬ ОКНО В ДРУГОМ МЕСТЕ, ВАМ НЕОБХОДИМО АДАПТИРОВАТЬ ИНСТРУКЦИИ К ВЫБРАННОМУ ПОЛОЖЕНИЮ · W INSTRUKCJI KROKI SĄ ZILUSTROWANE DLA TEJ POZYCJI; NALEŻY PAMIĘTAĆ, ŻE W PRZYPADKU WYBRANIA INNEGO MIEJSCA MONTAŻU OKNA, INSTRUKCJE NALEŻY DOSTOSOWAĆ DO WYBRANEJ POZYCJI · A KÉZIKÖNYVBĒN A LÉPÉSEK ENNĚL A POZÍCIONÁL VANNAK SZEMÉLTETVE; KÉRJÜK, VEGYE FIGYELEMBE, HOGY HA AZ ABLAKOT EGY MÁSIK LEHETSÉGES PONTRA HELYEZI, AZ UTASÍTÁSOKAT A VÁLASZTOTT POZÍCIÓHOZ KELL IGAZÍTANIA.







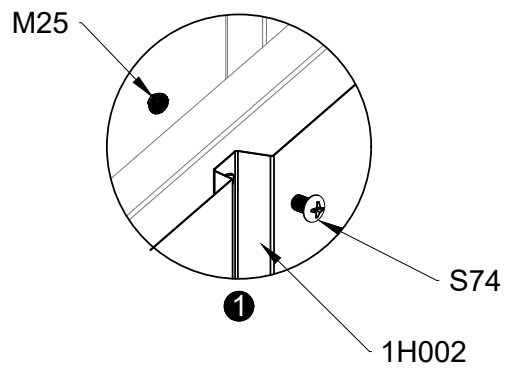

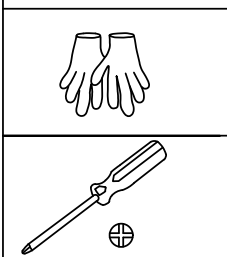
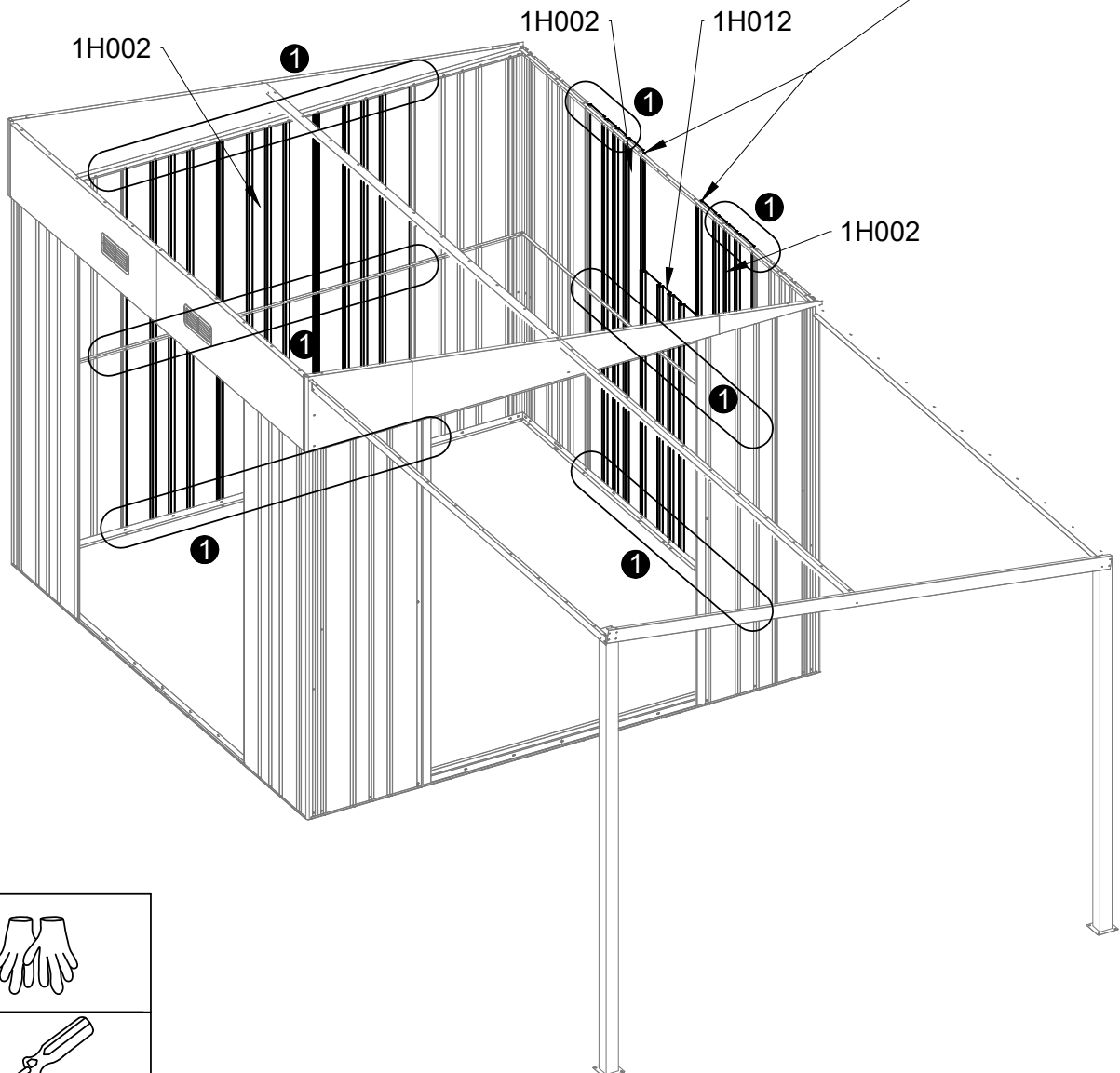

THANK YOU VERY MUCH FOR YOUR HELP! · ¡MUCHAS GRACIAS POR SU AYUDA! · MUITO OBRIGADO PELA SUA AJUDA! · MERCI BEAUCOUP POUR VOTRE AIDE! · VIELEN DANK FÜR IHRE HILFE! · ΣΑΣ ΕΥΧΑΡΙΣΤΟΥΜΕ ΠΟΛΥ ΓΙΑ ΤΗ ΒΟΗΘΕΙΑ ΣΑΣ! · GRAZIE MILLE PER IL VOSTRO AIUTO! · ĐÁKUJEME VELMI PEKNE ZA VAŠU POMOC! · PUNO VAM HVALA NA POMOCI! · ĐĚKUJEME VÁM MOC ZA VAŠI POMOC! · NAJLEPŠA HVALA ZA VAŠO POMOC! · TACK SÅ MYCKET FÖR DIN HJÄLP! · YARDIMLARINIZ İÇİN ÇOK TEŞEKKÜR EDERİM! · SHUME FALEMINDERIT PËR NDIHMËN TUAJ! · БОЛЬШОЕ СПАСИБО ЗА ВАШУ ПОМОЩЬ! · BARDZO DZIĘKUJEMY ZA POMOC! · NAGYON KÖSZÖNJÜK A SEGÍTSÉGE

PART	NO	QTY
	1H002	5
	1H012	1
	S74 M4X8	101
	M25 M4	101







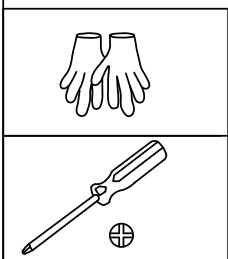
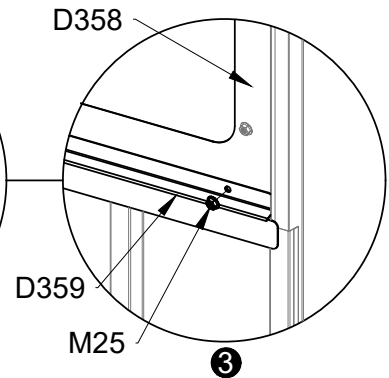
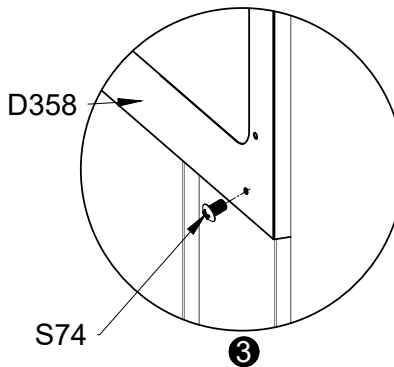
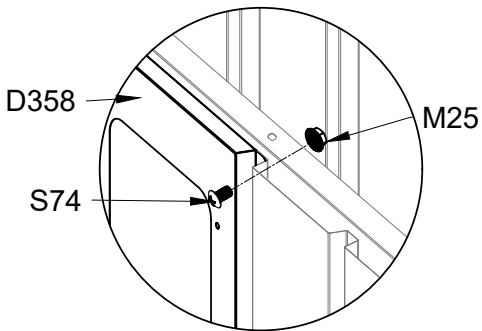
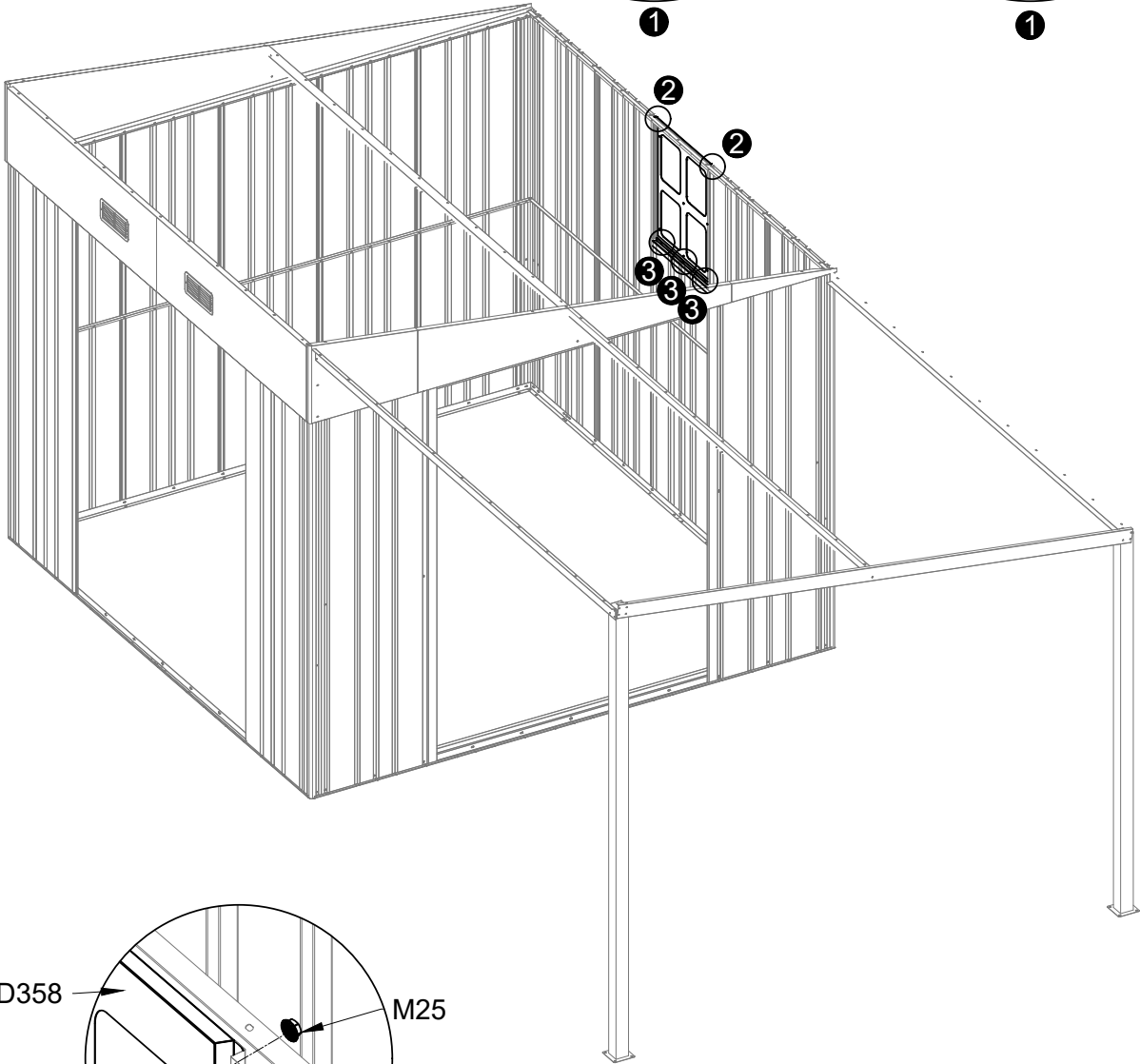
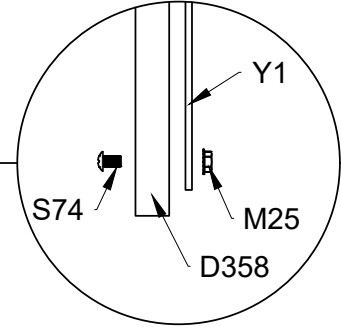
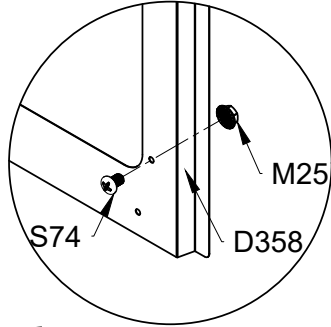
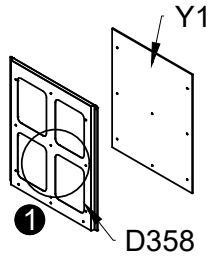

DO NOT INSTALL S74 IN THIS HOLE · NO INSTALE EL S74 EN ESTE ORIFICIO · NÃO INSTALAR O S74 NESTE ORIFÍCIO · NE PAS INSTALLER LE S74 DANS CE TROU · S74 NICHT IN DIESEM LOCH INSTALLIEREN · ΜΗΝ ΕΓΚΑΤΑΣΤΗΣΕΤΕ ΤΟ S74 ΣΕ ΑΥΤΗΝ ΤΗΝ ΟΠΗ · NON INSTALLARE L'S74 IN QUESTO FORO · NEINSTALUJTE S74 DO TOHTO OTVORU · NEMOJTE INSTALIRATI S74 U OVU RUPU · NEINSTALUJTE S74 DO TOHOTÓ OTVORU · NE NAMEŠČAJTE S74 V TO LUKNJO · INSTALLERA INTE S74 I DETTA HÅL · S74'U BU DELİĞE MONTE ETMEYİN · MOS E INSTALONI S74 NĚ KĚTĚ VRIMĚ · НЕ УСТАНОВЛИВАЙТЕ S74 В ЭТО ОТВЕРСТИЕ · NIE INSTALOWAĆ S74 W TYM OTWORZE · NE TELEPÍTSE AZ S74-ET EBBE A FURATBA



PART	NO	QTY
	D358	1
	D359	1
	Y1	1
	S74	15
	M4X8	
	M25	
	M4	15





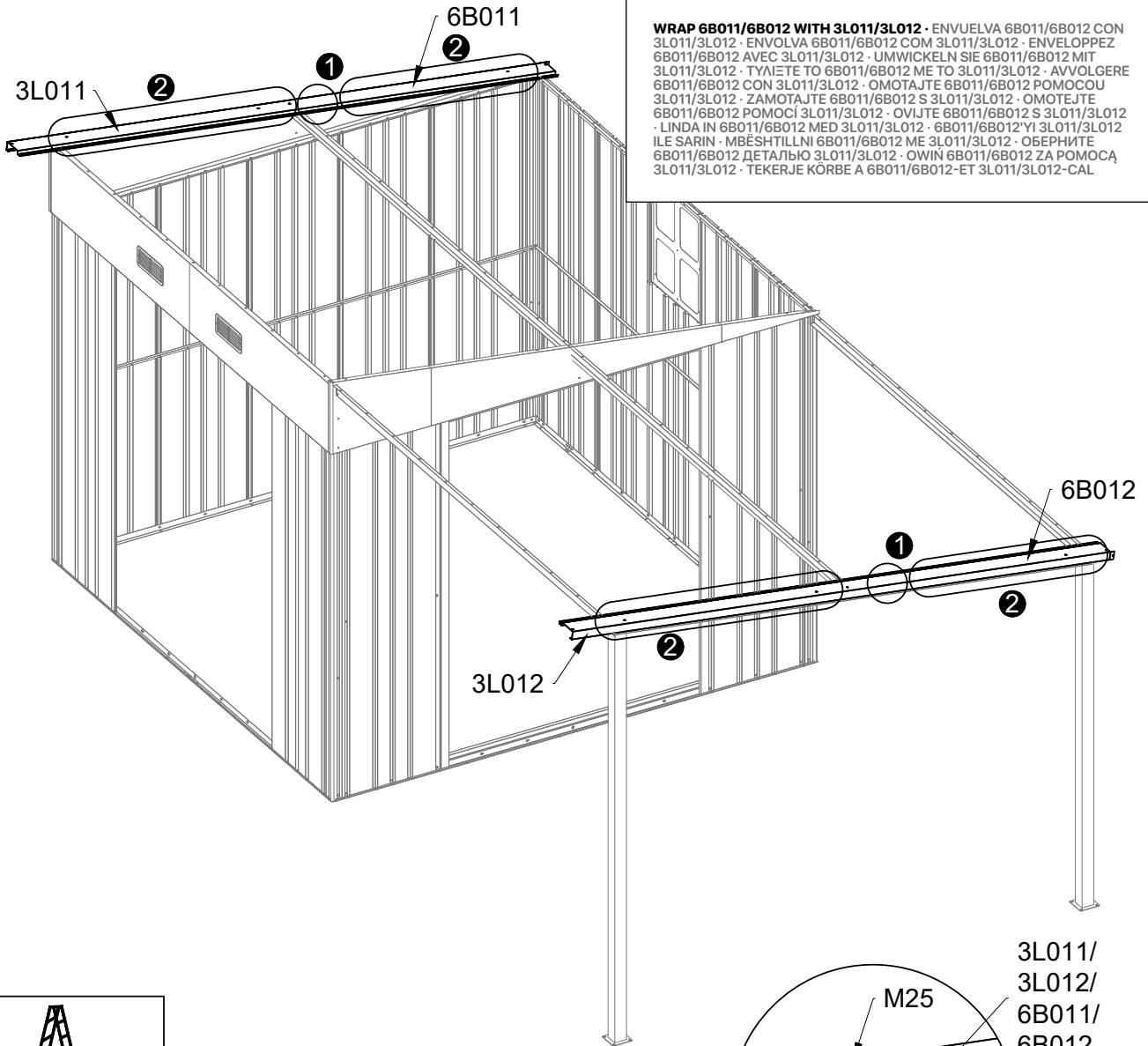
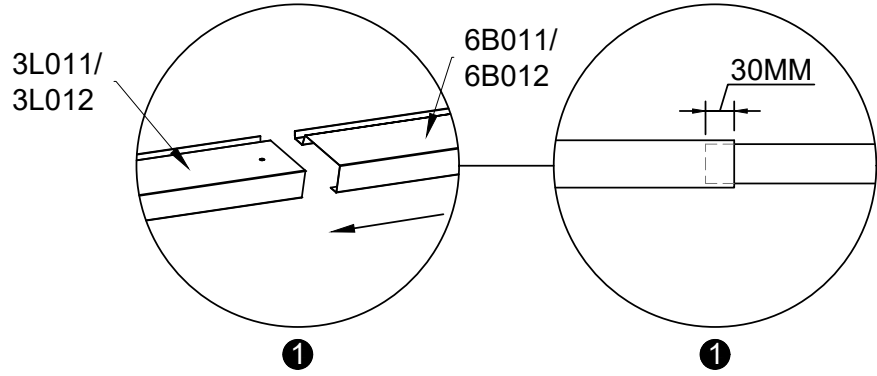

PART	NO	QTY
	3L011	1
	3L012	1
	6B011	1
	6B012	1
	S74 M4X8	12
	M25 M4	12

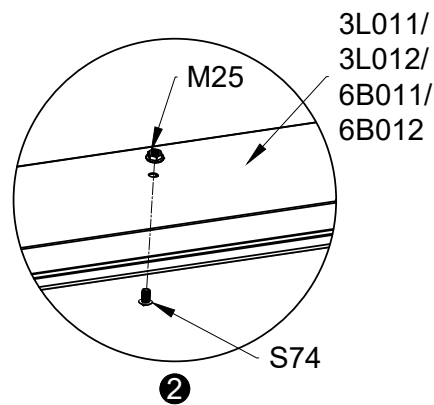
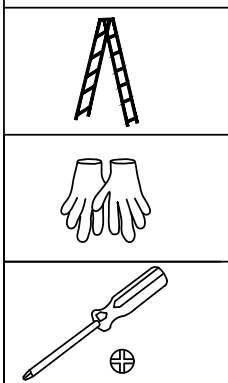





WRAP 6B011/6B012 WITH 3L011/3L012 - ENVUELVA 6B011/6B012 CON 3L011/3L012 - ENVOLVA 6B011/6B012 COM 3L011/3L012 - ENVELOPEZ 6B011/6B012 AVEC 3L011/3L012 - UMWICKELN SIE 6B011/6B012 MIT 3L011/3L012 - TYLIETE TO 6B011/6B012 ME TO 3L011/3L012 - AVVOLGERE 6B011/6B012 CON 3L011/3L012 - OMOTAJTE 6B011/6B012 POMOCOU 3L011/3L012 - ZAMOTAJTE 6B011/6B012 S 3L011/3L012 - OMOTEJTE 6B011/6B012 POMOCI 3L011/3L012 - OVIJTE 6B011/6B012 S 3L011/3L012 - LINDA IN 6B011/6B012 MED 3L011/3L012 - 6B011/6B012'YI 3L011/3L012 ILE SARIN - MBESHITLNI 6B011/6B012 ME 3L011/3L012 - OBERNIITE 6B011/6B012 DETAL'YU 3L011/3L012 - OWIN 6B011/6B012 ZA POMOČA 3L011/3L012 - TEKERJE KÖRBE A 6B011/6B012-ET 3L011/3L012-CAL

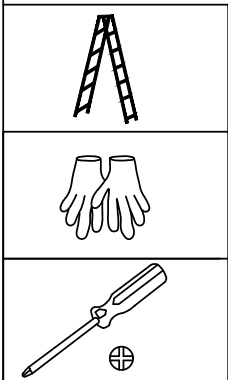
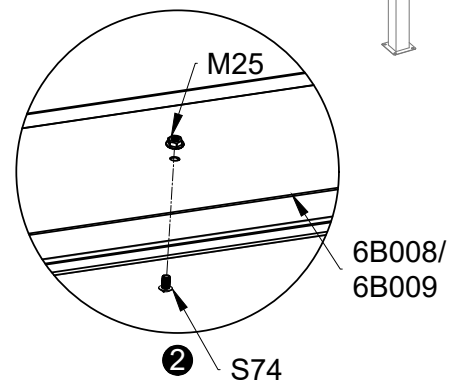
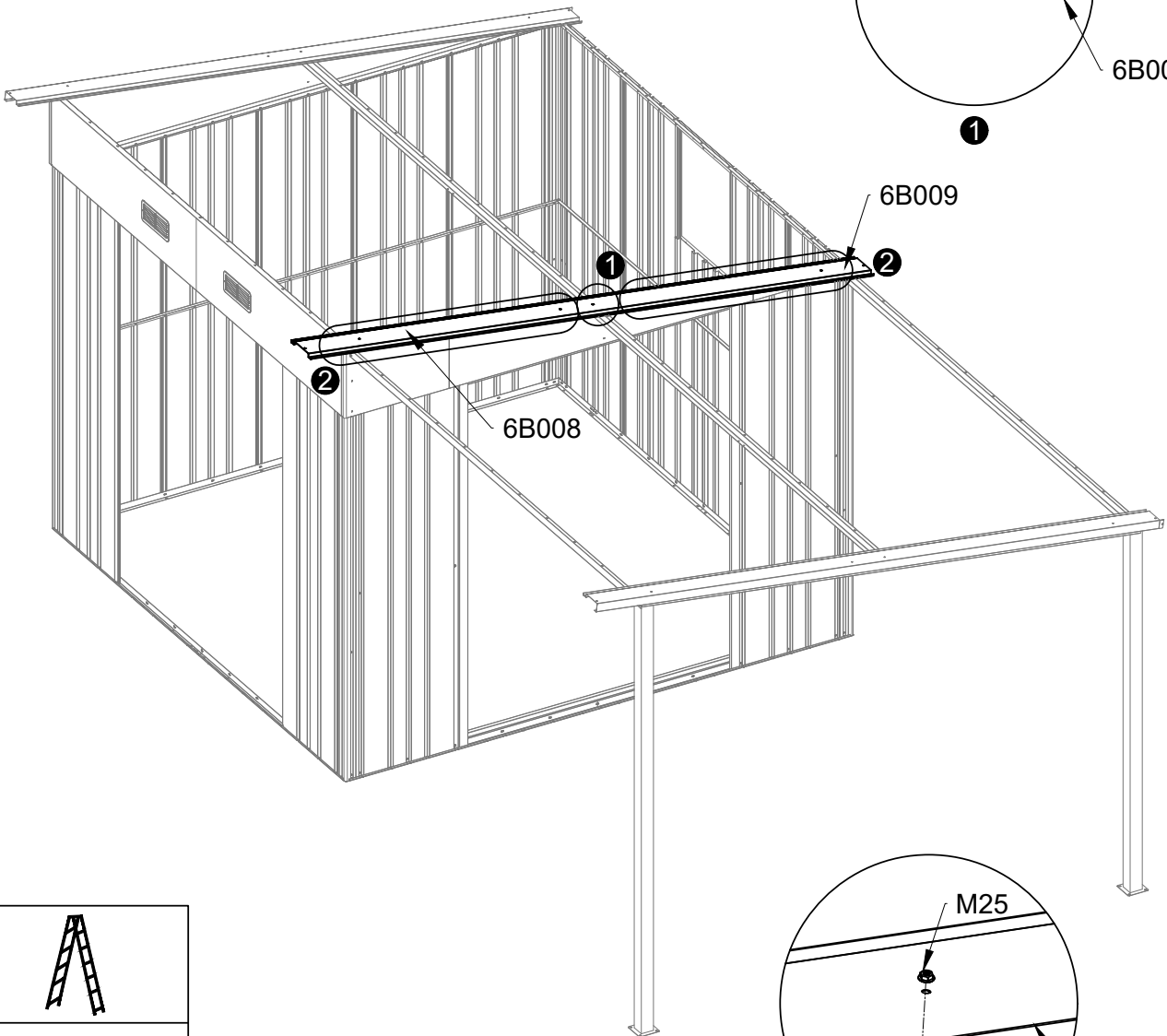
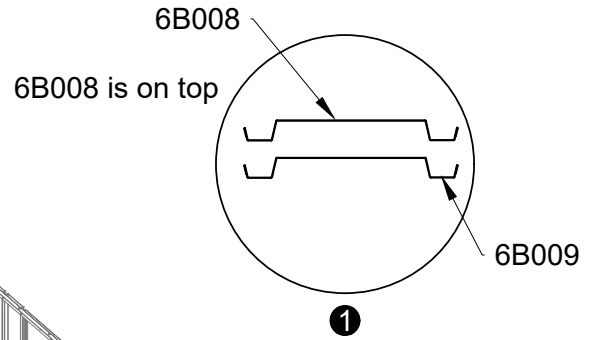
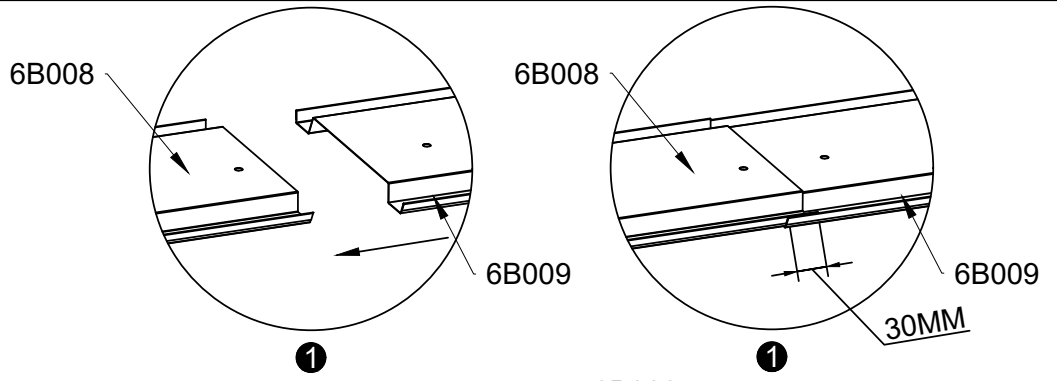





PART	NO	QTY
	6B008	1
	6B009	1
	S74	8
	M4X8	
	M25	8
	M4	

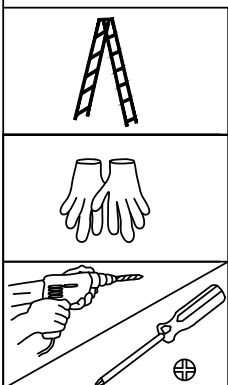
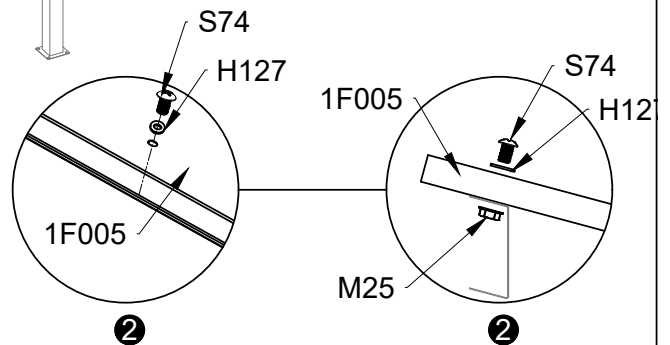
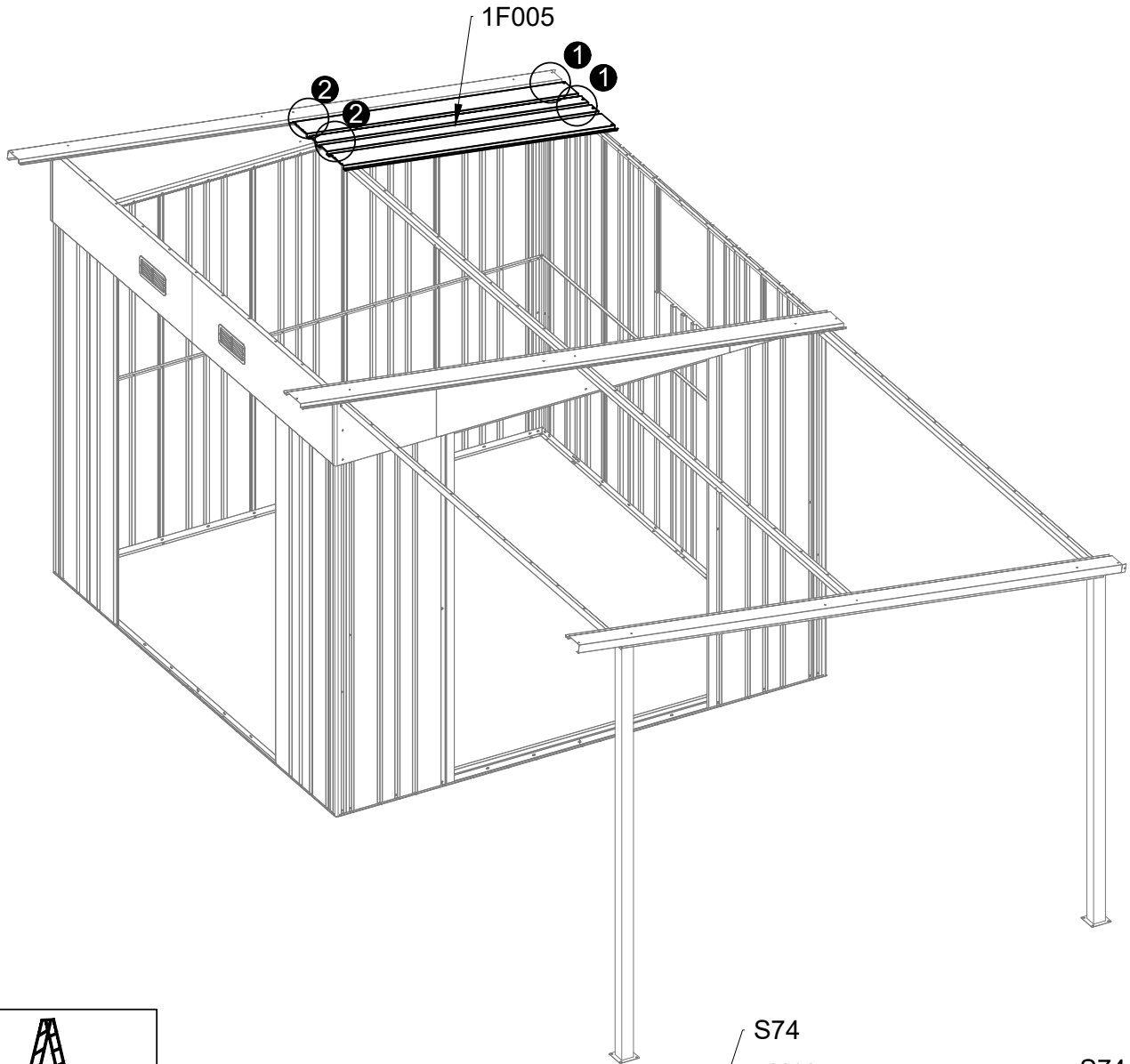
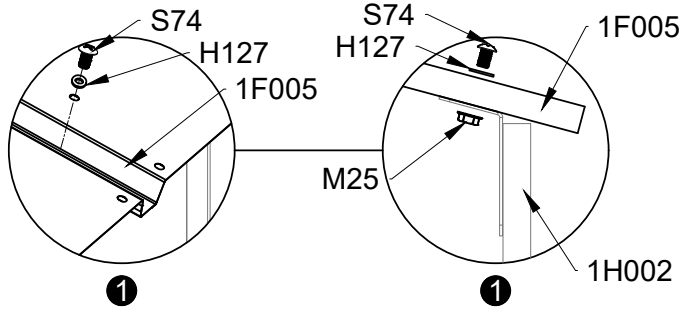





PART	NO	QTY
	1F005	1
	S74 M4X8	4
	M25 M4	4
	H127	4

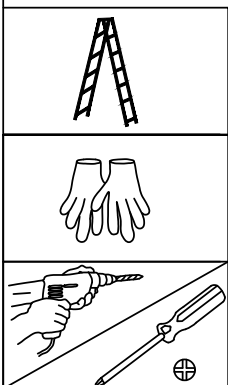
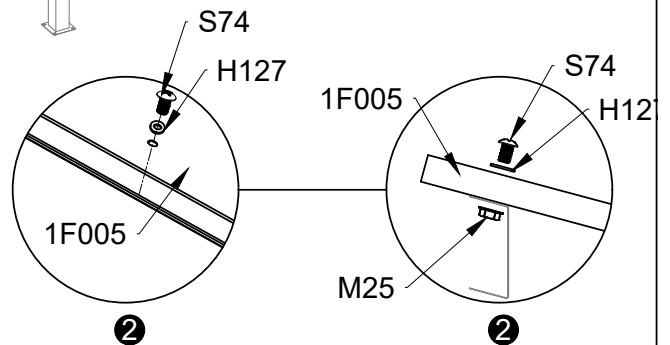
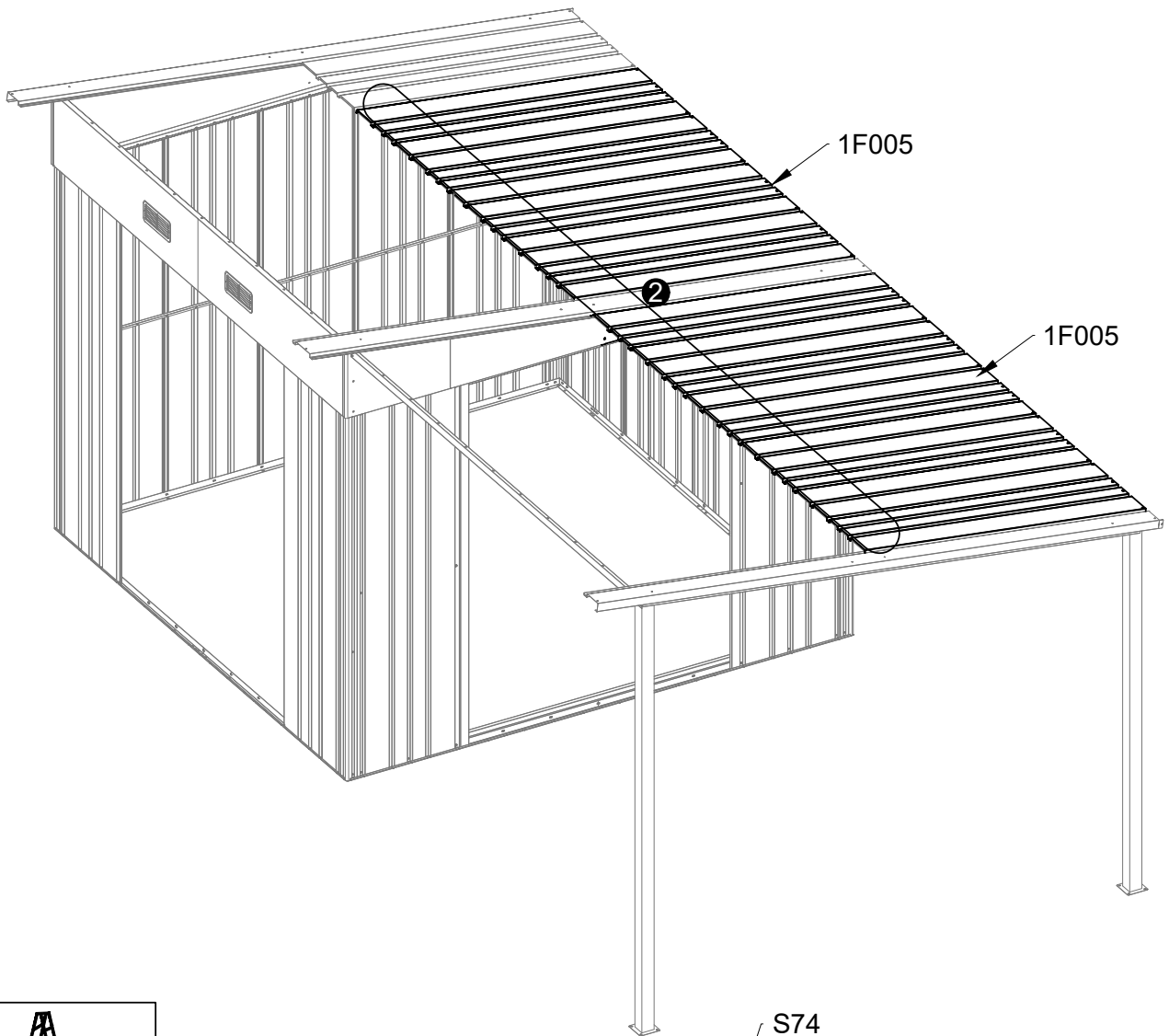
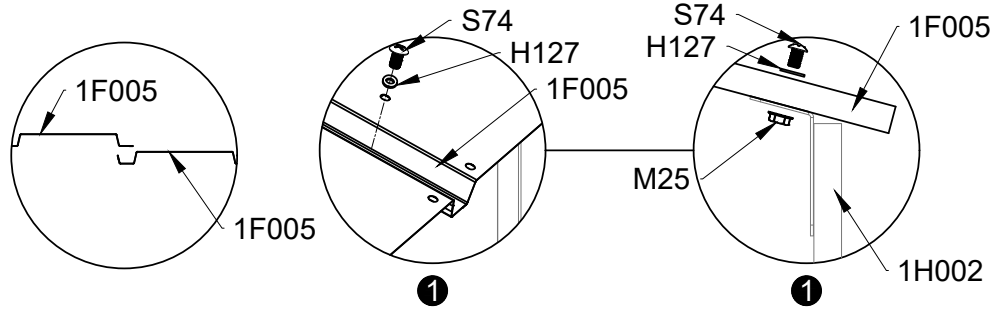

PART	NO	QTY
	1F005	9
	S74 M4X8	38
	M25 M4	38
	H127	38



PART	NO	QTY
	1F006	10
	S74 M4X8	62
	M25 M4	62
	H127	62

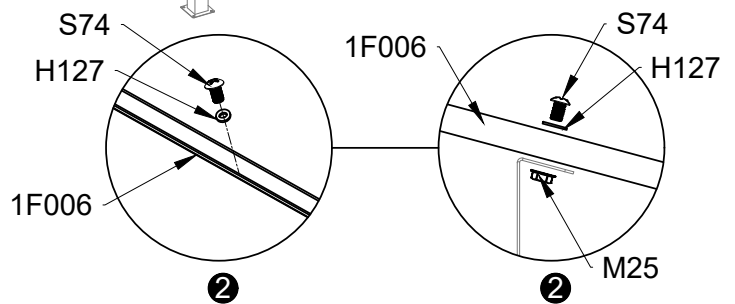
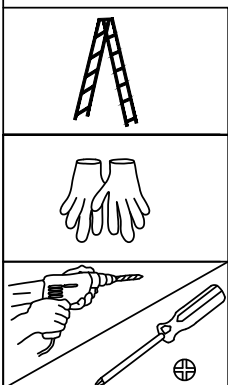
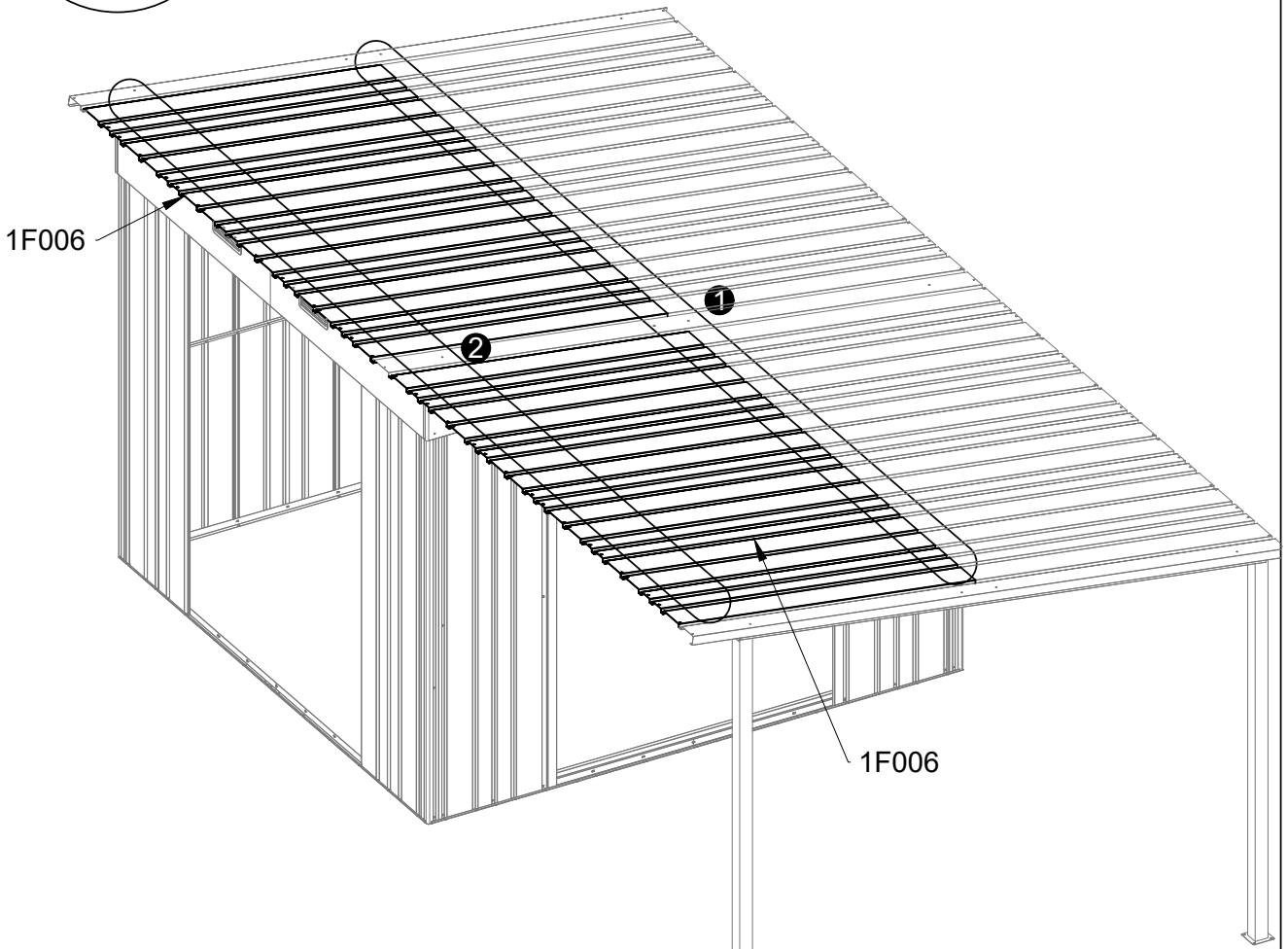
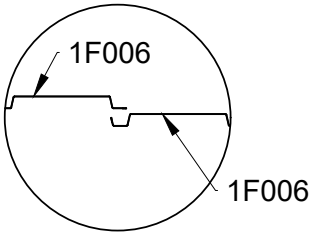
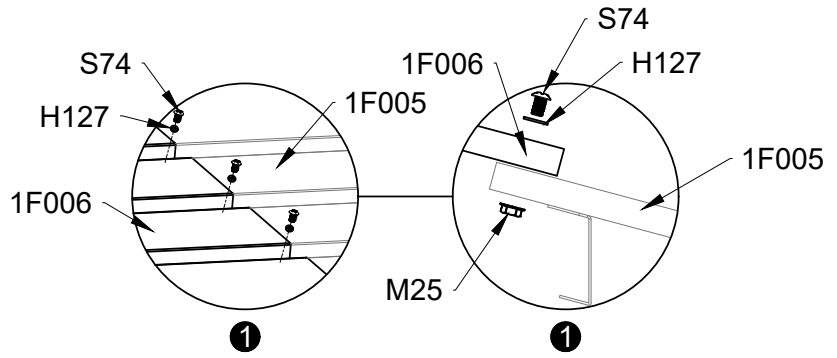

PART	NO	QTY
	3J006	2
	3J007	2
	3J011	2
	3J019	1
	3J020	1
	S74 M4X8	28
	M25 M4	28

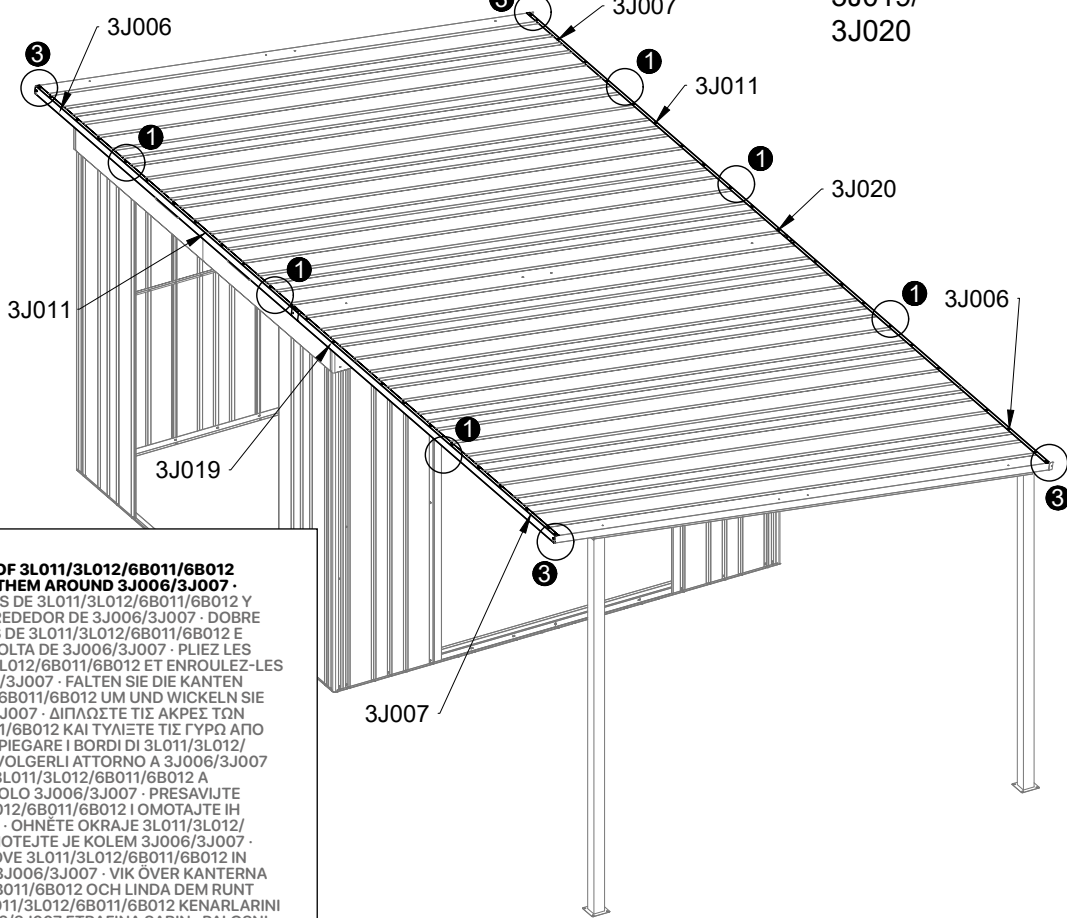
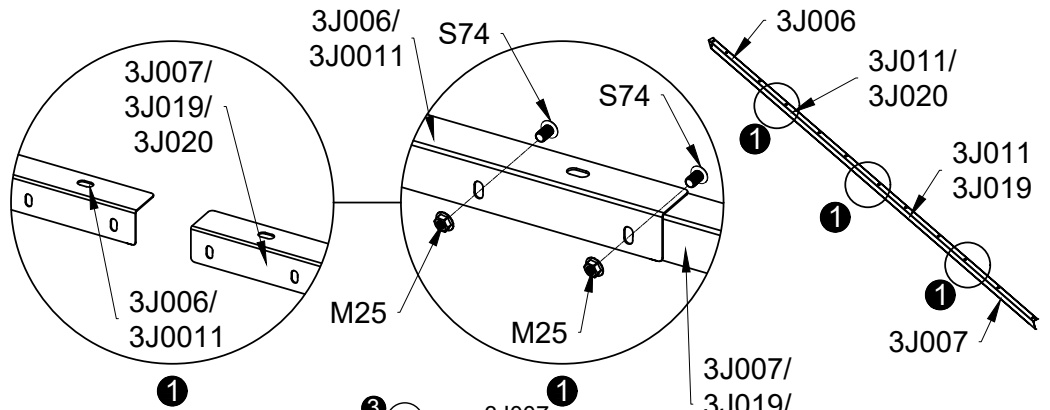

FOLD THE EDGES OF 3L011/3L012/6B011/6B012 OVER AND WRAP THEM AROUND 3J006/3J007 ·
 DOBLE LOS BORDES DE 3L011/3L012/6B011/6B012 Y ENVUÉLVALOS ALREDEDOR DE 3J006/3J007 · DOBRE AS EXTREMIDADES DE 3L011/3L012/6B011/6B012 E ENVOLVA-AS EM VOLTA DE 3J006/3J007 · PLIEZ LES BORDS DE 3L011/3L012/6B011/6B012 ET ENROULEZ-LES AUTOUR DE 3J006/3J007 · FALTEN SIE DIE KANTEN VON 3L011/3L012/6B011/6B012 UM UND WICKELN SIE DIESE UM 3J006/3J007 · ΔΙΠΛΩΣΤΕ ΤΙΣ ΑΚΡΕΣ ΤΩΝ 3L011/3L012/6B011/6B012 ΚΑΙ ΤΥΛΙΞΤΕ ΤΙΣ ΓΥΡΩ ΑΠΟ ΤΟ 3J006/3J007 · PIEGARE I BORDI DI 3L011/3L012/6B011/6B012 E AVVOLGERLI ATTORNO A 3J006/3J007 · OHNITE OKRAJE 3L011/3L012/6B011/6B012 A OMOTAJTE ICH OKOLO 3J006/3J007 · PRESAVIJTE RUBOVE 3L011/3L012/6B011/6B012 I OMOTAJTE IH OKO 3J006/3J007 · OHNĚTE OKRAJE 3L011/3L012/6B011/6B012 A OMOTEJTE JE KOLEM 3J006/3J007 · PREPOGNITE ROBOVE 3L011/3L012/6B011/6B012 IN JIH OVIJTE OKOLI 3J006/3J007 · VIK ÖVER KANTERNA PÅ 3L011/3L012/6B011/6B012 OCH LINDA DEM RUNT 3J006/3J007 · 3L011/3L012/6B011/6B012 KENARLARINI KATLAYIN VE 3J006/3J007 ETRAFINA SARIN · PALOSNI SKAJET E 3L011/3L012/6B011/6B012 DHE MBËSH-TILLNI ATO RRETH 3J006/3J007 · СОГНИТЕ КРАЯ 3L011/3L012/6B011/6B012 И ОБЕРНИТЕ ИХ ВОКРУГ 3J006/3J007 · ZAGNIJ KRAWĘDZIE 3L011/3L012/6B011/6B012 I OWIŃ JE WOKOŁ 3J006/3J007 · HAJTSA BE A 3L011/3L012/6B011/6B012 ÉLEIT, ÉS TEKERJE ÖKET A 3J006/3J007 KÖRÉ

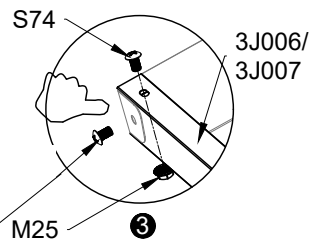
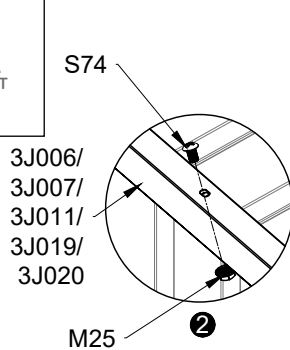

S74 (INSTALL NUT M25 ON THE INSIDE) · S74 (INSTALE LA TUERCA M25 EN EL INTERIOR) · S74 (INSTALLAR A PORCA M25 NO INTERIOR) · S74 (INSTALLER L'ECROU M25 À L'INTÉRIEUR) · S74 (MUTTER M25 AUF DER INNENSEITE MONTIEREN) · S74 (ΤΟΠΟΘΕΤΗΣΤΕ ΤΟ ΠΑΞΙΜΑΔΙ Μ25 ΣΤΟ ΕΣΩΤΕΡΙΚΟ) · S74 (INSTALLARE IL DADO M25 ALL'INTERNO) · S74 (NAINSTALUJTE MATICU M25 NA VNĚTORNĚ STRANU) · S74 (UGRADITE MATICU M25 S UNUTARNJE STRANE) · S74 (NAMONTUJTE MATICI M25 NA VNITRNI STRANU) · S74 (NAMESTITE MATICO M25 NA NOTRANJO STRAN) · S74 (INSTALLERA MUTTER M25 PÅ INSIDAN) · S74 (M25 SOMONU İÇ TARAFI TAKIN) · S74 (INSTALONI DADON M25 NĚ PJEŠĚN E BRENDSHME) · S74 (УСТАНОВИТЕ ГАЙКУ М25 НА БЪНТРЕПЕШИКОУ СТОРОНУ) · S74 (ZAMONTUJ NAKRĘTKĘ M25 OD WEWNĄTRZ) · S74 (SZERELJE FEL AZ M25-ÖS ANYÁT A BELSŐ OLDALRA)

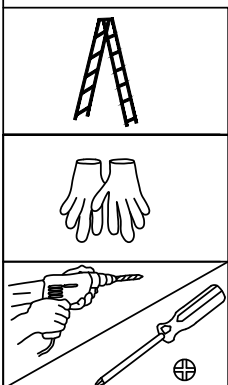

PART	NO	QTY
	6B013	2
	H48	4
	M11	4
	M6	

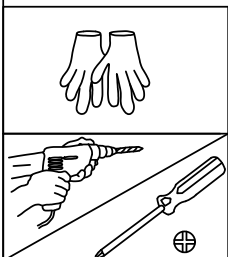
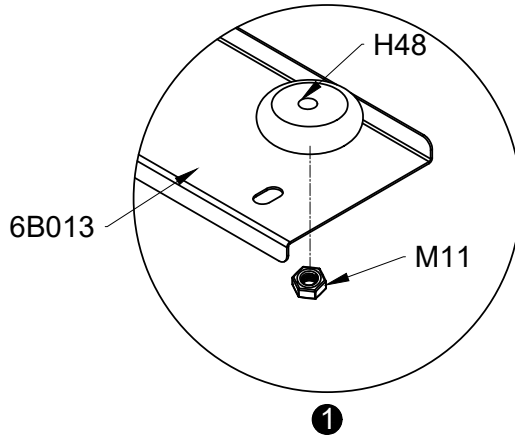
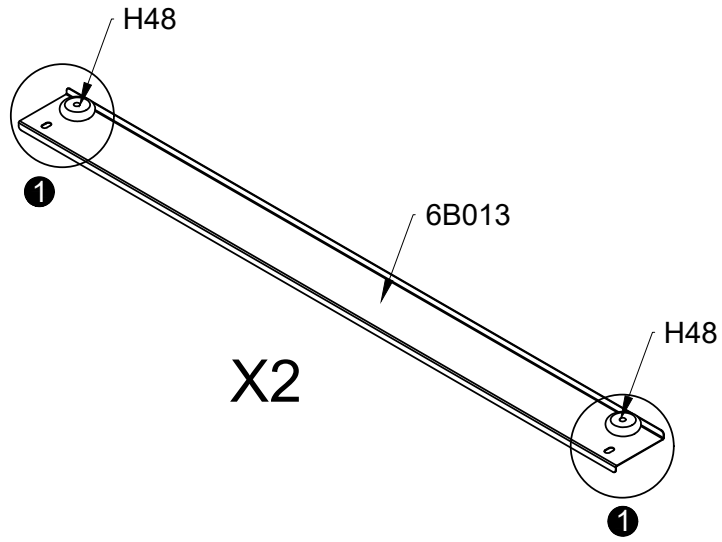

PART	NO	QTY
	S74	4
	M4X8	

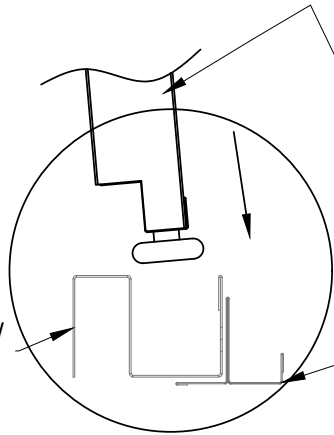

1

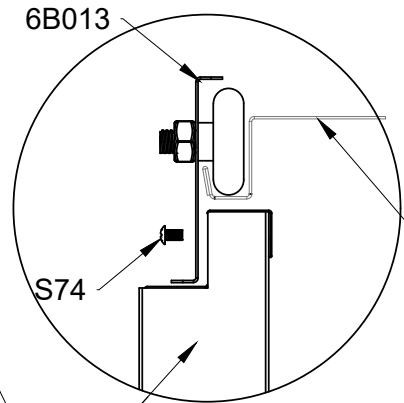

2

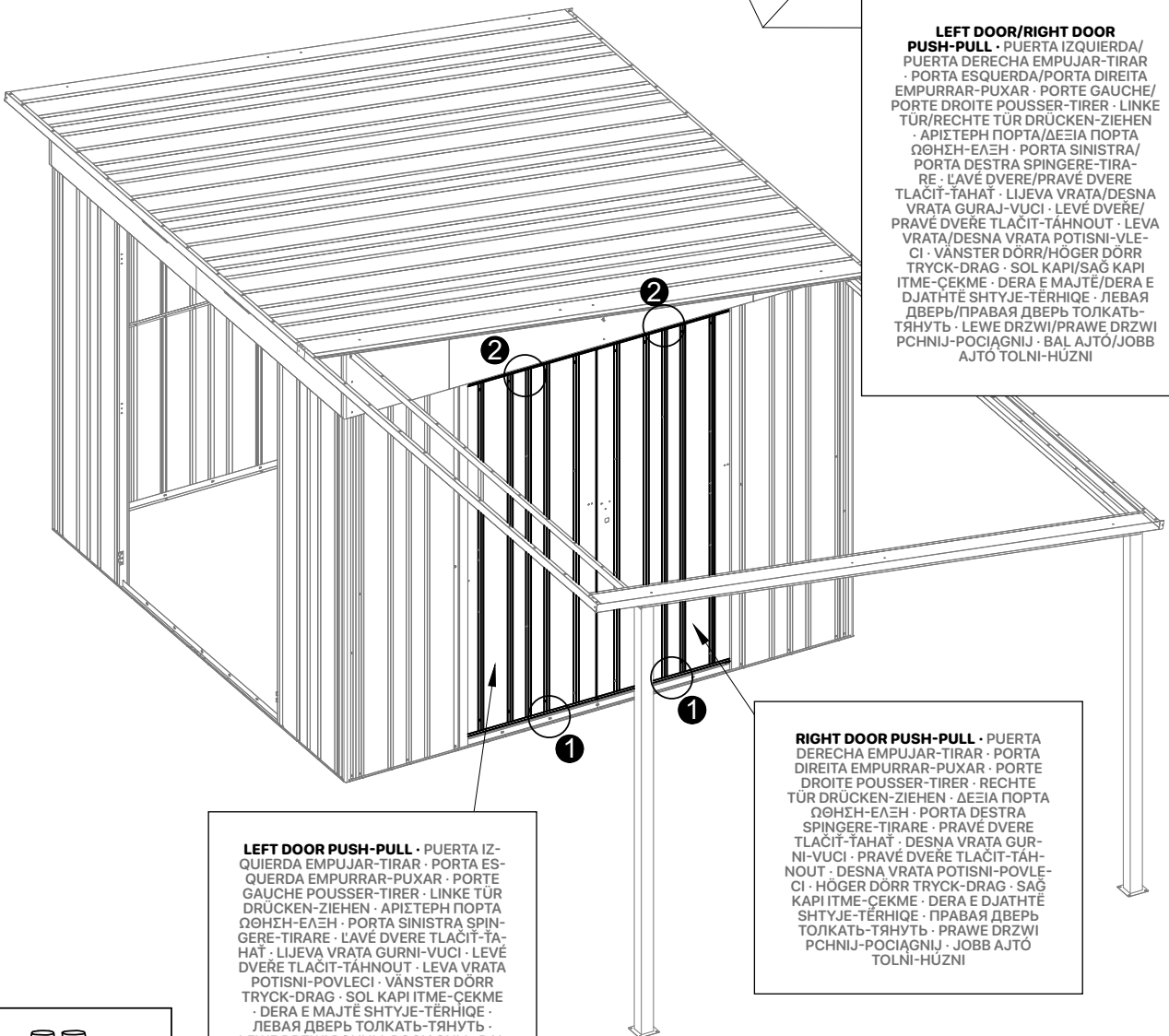

**LEFT DOOR/RIGHT DOOR
PUSH-PULL** · PUERTA IZQUIERDA/
PUERTA DERECHA EMPUJAR-TIRAR
· PORTA ESQUERDA/PORTA DIREITA
EMPURRAR-PUXAR · PORTE GAUCHE/
PORTE DROITE POUSSER-TIRER · LINKE
TÜR/RECHTE TÜR DRÜCKEN-ZIEHEN
· ΑΡΙΣΤΕΡΗ ΠΟΡΤΑ/ΔΕΞΙΑ ΠΟΡΤΑ
ΩΘΗΣΗ-ΕΛΞΗ · PORTA SINISTRA/
PORTA DESTRA SPINGERE-TIRA-
RE · L'AVÉ DVERE/PRAVÉ DVERE
TLAČIT-TAĤAĤ · LIJEVA VRATA/DESNA
VRATA GURAJ-VUCI · LEVÉ DVERÉ/
PRAVÉ DVERÉ TLAČIT-TÁHNOUT · LEVA
VRATA/DESNA VRATA POTISNI-VLE-
CI · VÄNSTER DÖRR/HÖGER DÖRR
TRYCK-DRAG · SOL KAPI/SAĞ KAPI
ITME-ÇEKME · DERA E MAJTË/DERA E
DJATHË SHYTYJE-TËRHIQE · ЛЕВАЯ
ДВЕРЬ/ПРАВАЯ ДВЕРЬ ТОЛКАТЬ-
ТЯНУТЬ · LEWE DRZWI/PRAWÉ DRZWI
PCHNIJ-POCIAGNIJ · BAL AJTÓ/JOBB
AJTÓ TOLNI-HÚZNI

LEFT DOOR PUSH-PULL · PUERTA IZ-
QUIERDA EMPUJAR-TIRAR · PORTA ES-
QUERDA EMPURRAR-PUXAR · PORTE
GAUCHE POUSSER-TIRER · LINKE TÜR
DRÜCKEN-ZIEHEN · ΑΡΙΣΤΕΡΗ ΠΟΡΤΑ
ΩΘΗΣΗ-ΕΛΞΗ · PORTA SINISTRA SPIN-
GERE-TIRARE · L'AVÉ DVERE TLAČIT-TA-
HĤAĤ · LIJEVA VRATA GURNI-VUCI · LEVÉ
DVERÉ TLAČIT-TÁHNOUT · LEVA VRATA
POTISNI-POVLECI · VÄNSTER DÖRR
TRYCK-DRAG · SOL KAPI ITME-ÇEKME
· DERA E MAJTË SHYTYJE-TËRHIQE ·
ЛЕВАЯ ДВЕРЬ ТОЛКАТЬ-ТЯНУТЬ ·
LEWE DRZWI PCHNIJ-POCIAGNIJ · BAL
AJTÓ TOLNI-HÚZNI

RIGHT DOOR PUSH-PULL · PUERTA
DERECHA EMPUJAR-TIRAR · PORTA
DIREITA EMPURRAR-PUXAR · PORTE
DROITE POUSSER-TIRER · RECHTE
TÜR DRÜCKEN-ZIEHEN · ΔΕΞΙΑ ΠΟΡΤΑ
ΩΘΗΣΗ-ΕΛΞΗ · PORTA DESTRA
SPINGERE-TIRARE · PRAVÉ DVERE
TLAČIT-TAĤAĤ · DESNA VRATA GUR-
NI-VUCI · PRAVÉ DVERÉ TLAČIT-TÁH-
NOUT · DESNA VRATA POTISNI-POVLE-
CI · HÖGER DÖRR TRYCK-DRAG · SAĞ
KAPI ITME-ÇEKME · DERA E MAJTË
SHYTYJE-TËRHIQE · ПРАВАЯ ДВЕРЬ
ТОЛКАТЬ-ТЯНУТЬ · PRAWÉ DRZWI
PCHNIJ-POCIAGNIJ · JOBB AJTÓ
TOLNI-HÚZNI

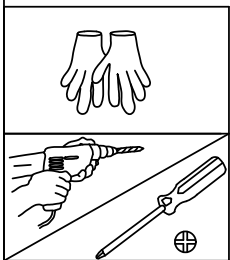

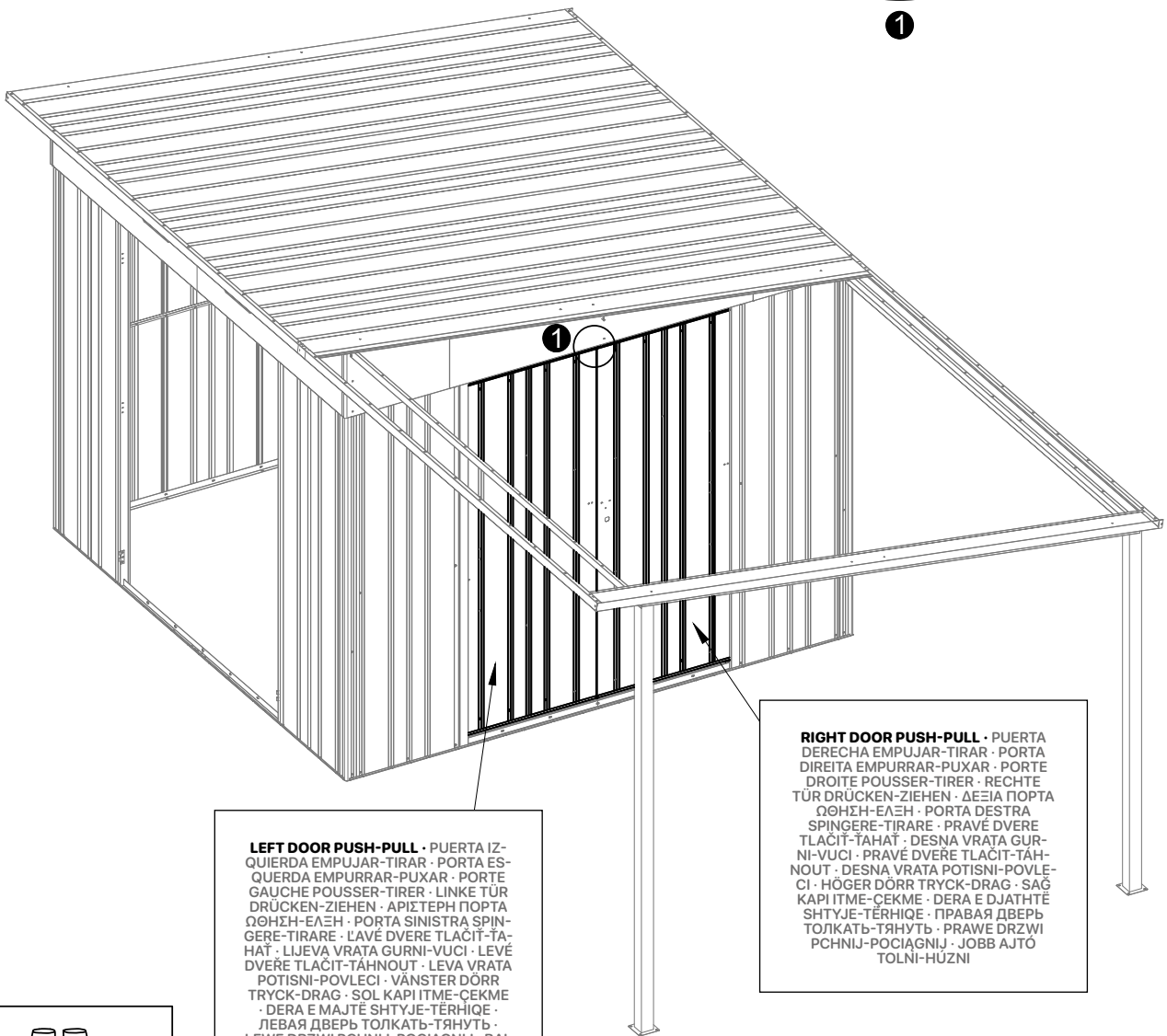
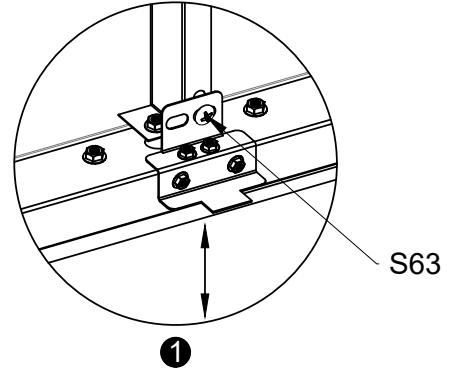

LEFT DOOR PUSH-PULL · PUERTA IZ-QUIERDA EMPUJAR-TIRAR · PORTA ES-QUERDA EMPURRAR-PUXAR · PORTE GAUCHE POUSSER-TIRER · LINKE TÜR DRÜCKEN-ZIEHEN · ΑΡΙΣΤΕΡΗ ΠΟΡΤΑ ΩΘΗΣΗ-ΕΛΞΗ · PORTA SINISTRA SPINGERE-TIRARE · L'AVÉ DVERE TLACIT-TÁHÁT · LIJEVA VRATA GURNI-VUCI · LEVÉ DVERE TLACIT-TÁHNOUT · LEVA VRATA POTISNI-POVLECI · VÄNSTER DÖRR TRYCK-DRAG · SOL KAPI ITME-ÇEKME · DERA E MAJTË SHTYJE-TËRHÏQE · ЛЕВАЯ ДВЕРЬ ТОЛКАТЬ-ТЯНУТЬ · LEWE DRZWI PCHNIJ-POCIAGNIJ · BAL AJTÓ TOLNI-HÚZNI

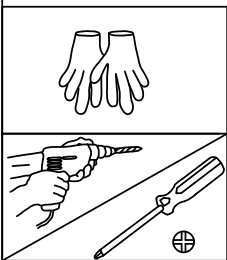

RIGHT DOOR PUSH-PULL · PUERTA DERECHA EMPUJAR-TIRAR · PORTA DIREITA EMPURRAR-PUXAR · PORTE DROITE POUSSER-TIRER · RECHTE TÜR DRÜCKEN-ZIEHEN · ΔΕΞΙΑ ΠΟΡΤΑ ΩΘΗΣΗ-ΕΛΞΗ · PORTA DESTRA SPINGERE-TIRARE · PRAVÉ DVERE TLACIT-TÁHÁT · DESNA VRATA GURNI-VUCI · PRAVÉ DVERE TLACIT-TÁHNOUT · DESNA VRATA POTISNI-POVLECI · HÖGER DÖRR TRYCK-DRAG · SAĞ KAPI ITME-ÇEKME · DERA E DJATHË SHTYJE-TËRHÏQE · ПРАВАЯ ДВЕРЬ ТОЛКАТЬ-ТЯНУТЬ · PRAWÉ DRZWI PCHNIJ-POCIAGNIJ · JOBB AJTÓ TOLNI-HÚZNI



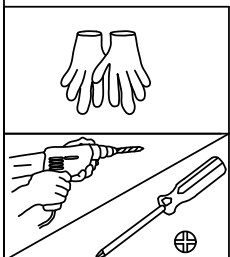
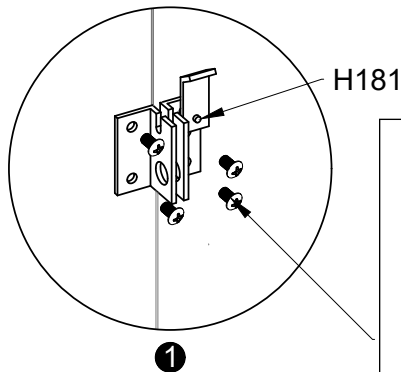
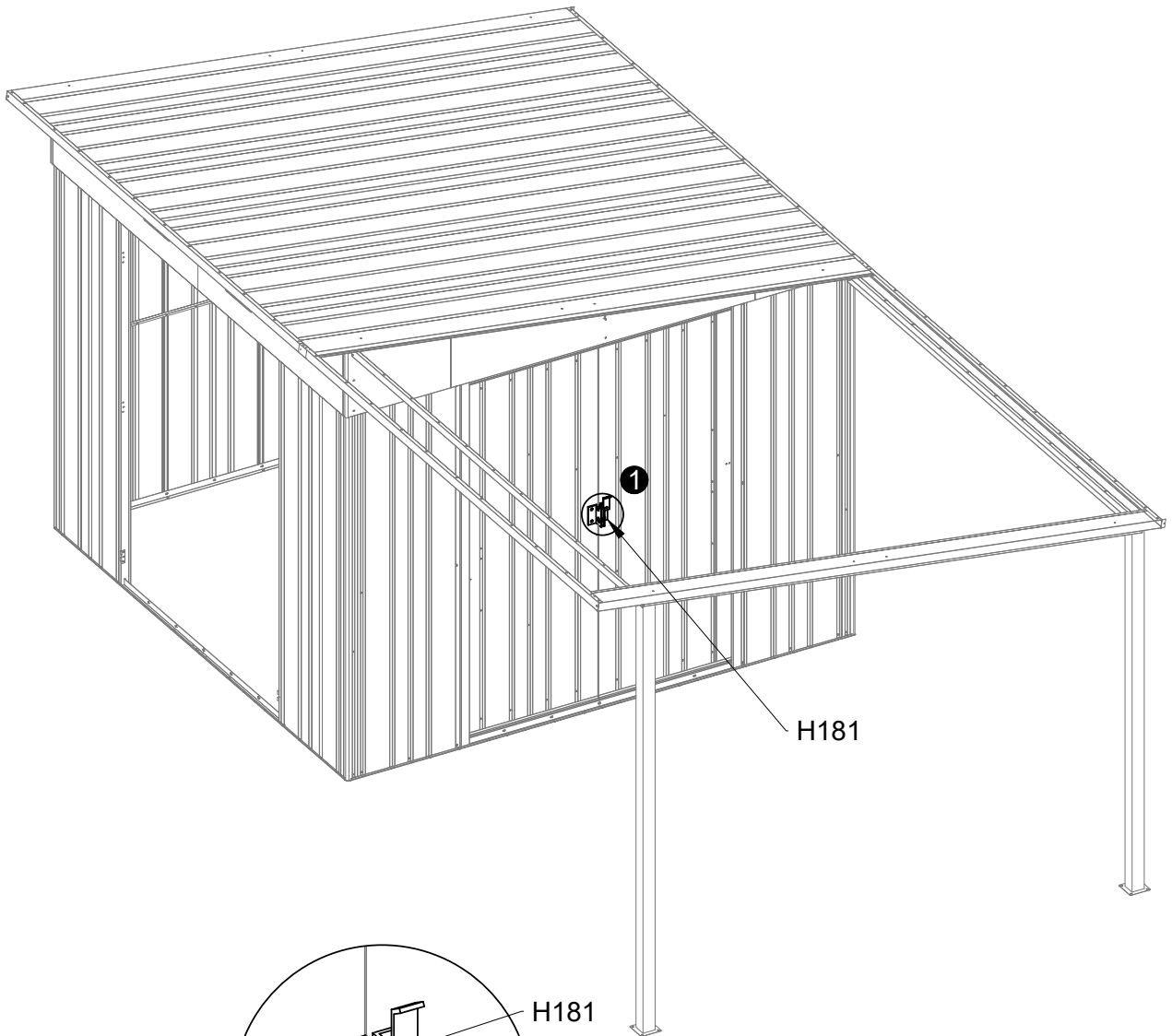

PART	NO	QTY
	S74	4
	M4X8	

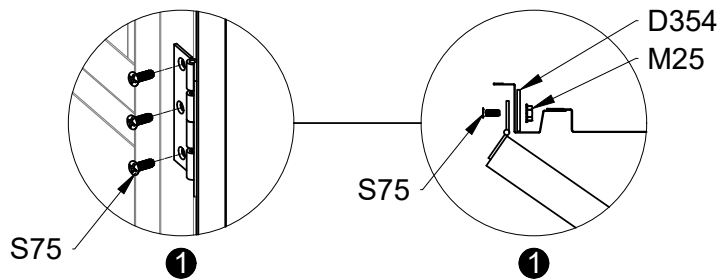
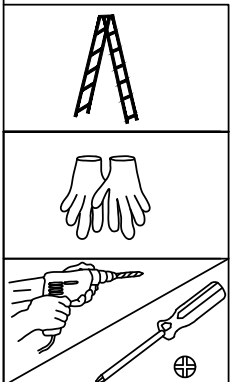
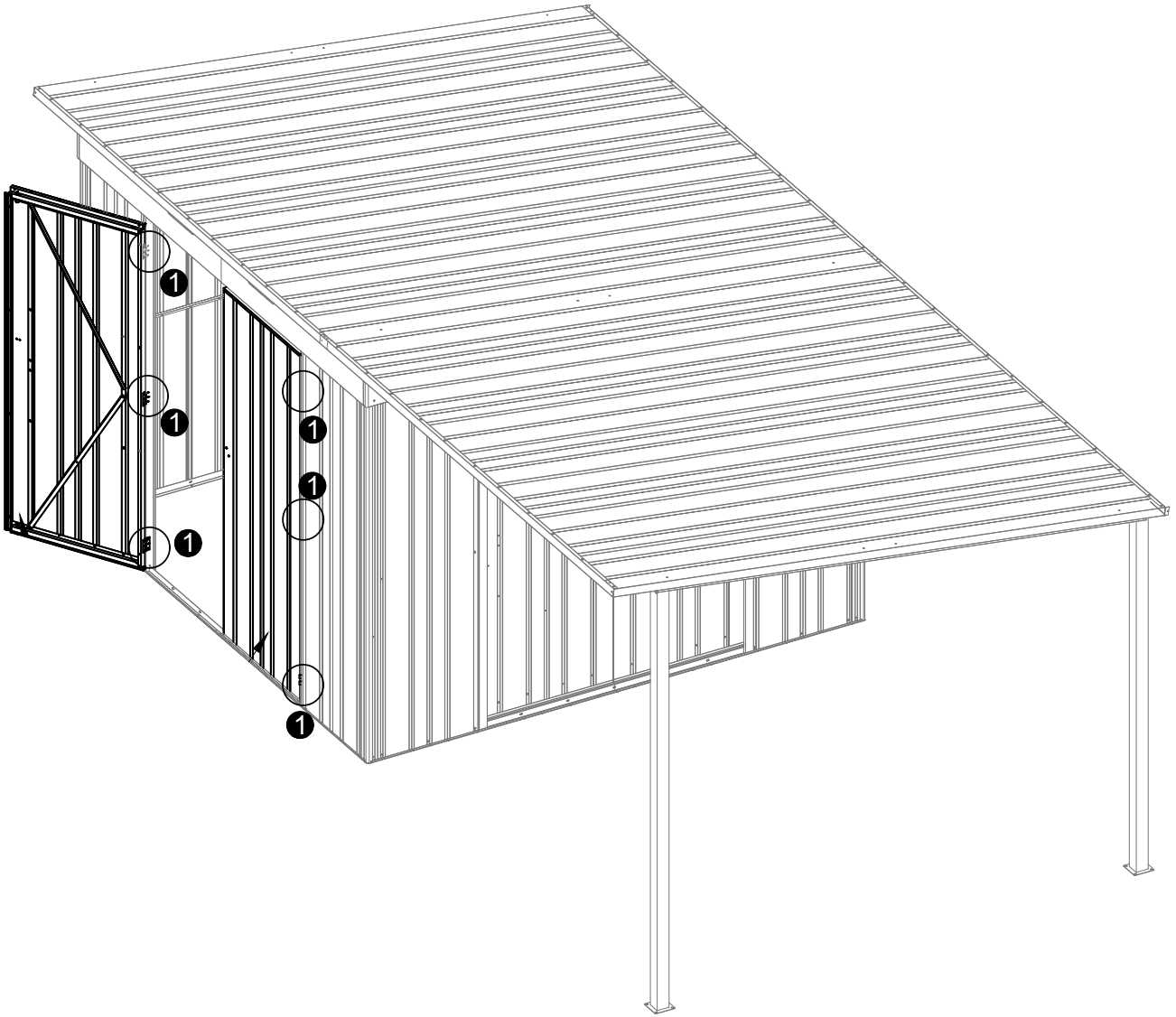

S74 (INSTALL NUT M25 ON THE INSIDE) · S74 (INSTALE LA TUERCA M25 EN EL INTERIOR) · S74 (INSTALAR A PORÇA M25 NO INTERIOR) · S74 (INSTALLER L'ÉCROU M25 À L'INTÉRIEUR) · S74 (MUTTER M25 AUF DER INNENSEITE MONTIEREN) · S74 (ΤΟΠΟΘΕΤΗΣΤΕ ΤΟ ΠΑΞΙΜΑΔΙ Μ25 ΣΤΟ ΕΣΩΤΕΡΙΚΟ) · S74 (INSTALLARE IL DADO M25 ALL'INTERNO) · S74 (NAINSTALUJTE MATICU M25 NA VNÚTORNÚ STRANU) · S74 (UGRADITE MATICU M25 S UNUTARNJE STRANE) · S74 (NAMONTUJTE MATICI M25 NA VNITRNI STRANU) · S74 (NAMESTITE MATICO M25 NA NOTRANJO STRAN) · S74 (INSTALLERA MUTTER M25 PÅ INSIDAN) · S74 (M25 SOMONU İÇ TARAFA TAKIN) · S74 (INSTALONI DADON M25 NÉ PJEŠÉN E BRENDSHME) · S74 (УСТАНОВИТЕ ГАЙКУ М25 НА ВНУТРЕШНЮЮ СТОРОНУ) · S74 (ZAMONTUJ NAKRETKE M25 OD WEWNĄTRZ) · S74 (SZERELJE FEL AZ M25-ÖS ANYÁT A BELSŐ OLDALRA)

PART	NO	QTY
	D354	6
	S75	18
	M4X10	
	M25	18
	M4	



PART	NO	QTY
	A112	1

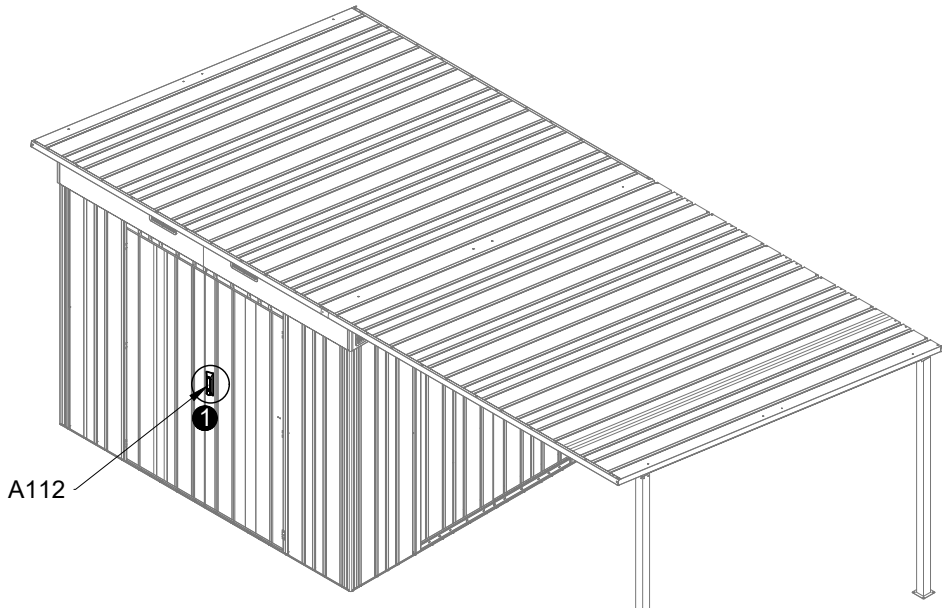

REMOVE THE FIXING IRON SHEET AND SCREWS OF A112 (DO NOT LOSE THEM) · RETIRE LA CHAPA DE HIERRO DE FIJACIÓN Y LOS TORNILLOS DE A112 (NO LOS PIERDA) · REMOVA A CHAPA DE FERRO DE FIXAÇÃO E OS PARAFUSOS DE A112 (NÃO OS PERCA) · RETIREZ LA TÔLE DE FIXATION EN FER ET LES VIS DE A112 (NE LES PERDEZ PAS) · ENTFERNEN SIE DAS BEFESTIGUNGSEISENBLECH UND DIE SCHRAUBEN VON A112 (VERLIEREN SIE DIESE NICHT) · ΑΦΑΙΡΕΣΤΕ ΤΟ ΣΙΔΕΡΕΝΙΟ ΕΛΑΣΜΑ ΣΤΕΡΕΩΣΗΣ ΚΑΙ ΤΙΣ ΒΙΔΕΣ ΤΟΥ Α112 (ΜΗΝ ΤΑ ΧΑΖΕΤΕ) · RIMUOVETE LA LAMIERA DI FISSAGGIO IN FERRO E LE VITI DI A112 (NON PERDERLE) · ODSTRÁŇTE UPEVNŔOVACÍ ŽELEZNÝ PLECH A SKRUTKY Z A112 (NESTRÁŇTE ICH) · UKLONITE PRÍČVRSNÚ ŽEL JEZNU PLOČU I VIJKE S A112 (NEMOJTE IH IZGUBITI) · ODSTRÁŇTE UPEVNŔOVACÍ ŽELEZNÝ PLECH A ŠROUBY Z A112 (NEZTRATÍŤ JE) · ODSTRANITE PRITRDILNO ŽELEZNO PLOŠČO IN VIJAKE A112 (NE IZGUBITE JIH) · TA BORT FIXERINGSJÄRNPLÄTEN OCH SKRUVARNA FRÅN A112 (TAPPA INTE BORT DEM) · A112'NIN SABITLEME DEMİR SACINI VE VIDALARINI ÇIKARIN (ONLARI KAYBETMEYİN) · HIQNI FLETĚN E HEKURIT FIKSUES DHE VIDAT E A112 (MOS I HUMBISNI ATO) · СНИМИТЕ КРЕПЕЖНУЮ ЖЕЛЕЗНУЮ ПЛАСТИНУ И ВИНТЫ А112 (НЕ ПОТЕРЯЙТЕ ИХ) · ZDEJMIJ ŽELAZNA BLAČE MOCUJACA I ŠRUBY A112 (NIE ZGUB ICH) · TÁVOLÍTSYA EL AZ A112 RÖGZÍTŐ VASLEMEZT ÉS CSAVAROKAT (NE VESZÍTSE EL ÖKET)

PLACE A112 IN THE CORRESPONDING POSITION · COLOQUE EL A112 EN LA POSICIÓN CORRESPONDIENTE · COLOQUE O A112 NA POSIÇÃO CORRESPONDENTE · PLACEZ L'A112 DANS LA POSITION CORRESPONDANTE · PLATZIEREN SIE A112 IN DER ENTSPRECHENDEN POSITION · ΤΟΠΟΘΕΤΗΣΤΕ ΤΟ Α112 ΣΤΗΝ ΑΝΤΙΣΤΟΙΧΗ ΘΕΣΗ · POSIZIONARE L'A112 NELLA POSIZIONE CORRISPONDENTE · UMIESTNITE A112 DO PRÍSLUŠNEJ POLOHY · POSTAVITE A112 U ODGOVARAJUĆI POLOŽAJ · UMÍSTĚTE A112 DO ODPOVÍDAJÍCÍ POLOHY · POSTAVITE A112 NA USTREZNO MESTO · PLACERA A112 I MOTSVARANDE LÅGE · A112'YI ILGILI KONUMA YERLESTIRİN · VENDOSENI A112 NĚ POZICIONIN PERKATĚS · УСТАНОВИТЕ А112 В СООТВЕТСТВУЮЩЕЕ ПОЛОЖЕНИЕ · UMIEŚĆ A112 W ODPowiedNIEJ POZYCJI · HELYEZZE AZ A112-T A MEGFELELŐ HELYZETBE

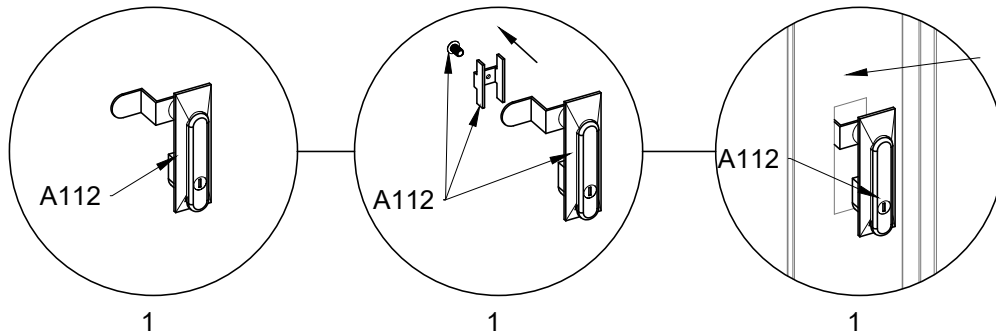

RIGHT DOOR ·
 PUERTA DERECHA
 · PORTA DIREITA
 · PORTE DROITE
 · RECHTE TÜR · ΔΕΞΙΑ ΠΟΡΤΑ · PORTA DESTRA · PRÁVĚ DVERĚ · DESNA VRATA · PRÁVĚ DVĚŘE · DESNA VRATA · HÖGER DÖRR · SAĞ KAPI · DERA E DJATHTĚ · ПРАВАЯ ДВЕРЬ · PRAWĚ DRZWI · JOBB AJTÓ

RE-SECURE THE REMOVED FIXING IRON SHEET AND SCREWS ON A112 · VUELVA A FIJAR LA CHAPA DE HIERRO Y LOS TORNILLOS RETIRADOS EN EL A112 · VOLTE A FIXAR A CHAPA DE FERRO E OS PARAFUSOS REMOVIDOS NO A112 · FIXEZ À NOUVEAU LA TÔLE DE FIXATION ET LES VIS RETIRÉES SUR L'A112 · BEFESTIGEN SIE DAS ENTFERNTE BEFESTIGUNGSEISENBLECH UND DIE SCHRAUBEN WIEDER AM A112 · ΕΠΑΝΑΤΟΠΟΘΕΤΗΣΤΕ ΤΟ ΣΙΔΕΡΕΝΙΟ ΕΛΑΣΜΑ ΣΤΕΡΕΩΣΗΣ ΚΑΙ ΤΙΣ ΒΙΔΕΣ ΠΟΥ ΑΦΑΙΡΕΣΑΤΕ ΣΤΟ Α112 · FISSARE NUOVAMENTE LA LAMIERA DI FISSAGGIO E LE VITI RIMOSSE SULL'A112 · ZNOVUJ UPEVNĚTE ODSTRANĚNÝ UPEVNŔOVACÍ ŽELEZNÝ PLECH A SKRUTKY NA A112 · PONOVRNO PRITRDITE ODSTRANJENO PRITRDILNO ŽELEZNO PLOŠČO IN VIJAKE NA A112 · SÁTT TILLBAKA FIXERINGSJÄRNPLÄTEN OCH SKRUVARNA PÅ A112 · ÇIKARILAN SABITLEME DEMİR SACINI VE VIDALARINI A112'YE TEKRAR SABITLEYİN · RIFIKSONI FLETĚN E HEKURIT DHE VIDAT E HEQURA NĚ A112 · СНОВА ЗАКРЕПИТЕ СНЯТУЮ ЖЕЛЕЗНУЮ ПЛАСТИНУ И ВИНТЫ НА А112 · PONOWNIE ZAMOCUJ ZDJĘTĄ BLAČĘ MOCUJACA I ŠRUBY NA A112 · RÖGZÍTSE VISSZA AZ ELTÁVOLÍTOTT RÖGZÍTŐ VASLEMEZT ÉS A CSAVAROKAT AZ A112-RE

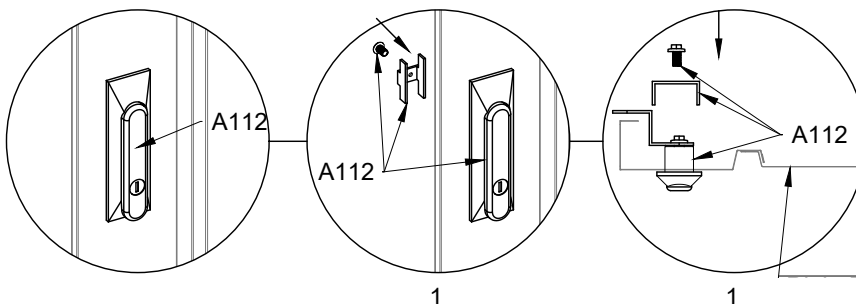
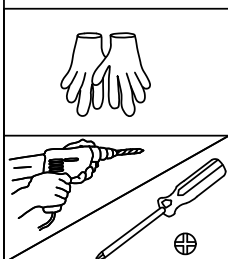

RIGHT DOOR ·
 PUERTA DERECHA
 · PORTA DIREITA
 · PORTE DROITE
 · RECHTE TÜR · ΔΕΞΙΑ ΠΟΡΤΑ · PORTA DESTRA · PRÁVĚ DVERĚ · DESNA VRATA · PRÁVĚ DVĚŘE · DESNA VRATA · HÖGER DÖRR · SAĞ KAPI · DERA E DJATHTĚ · ПРАВАЯ ДВЕРЬ · PRAWĚ DRZWI · JOBB AJTÓ

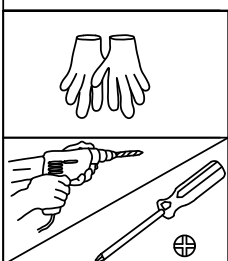
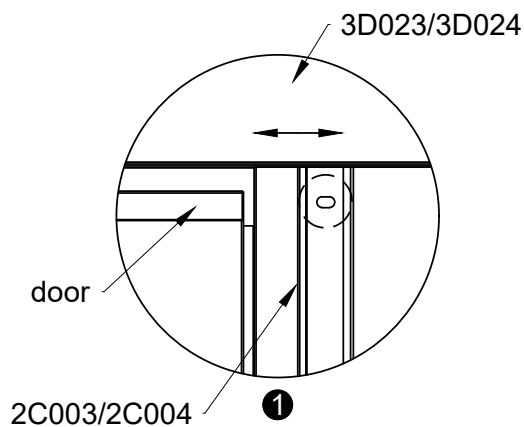
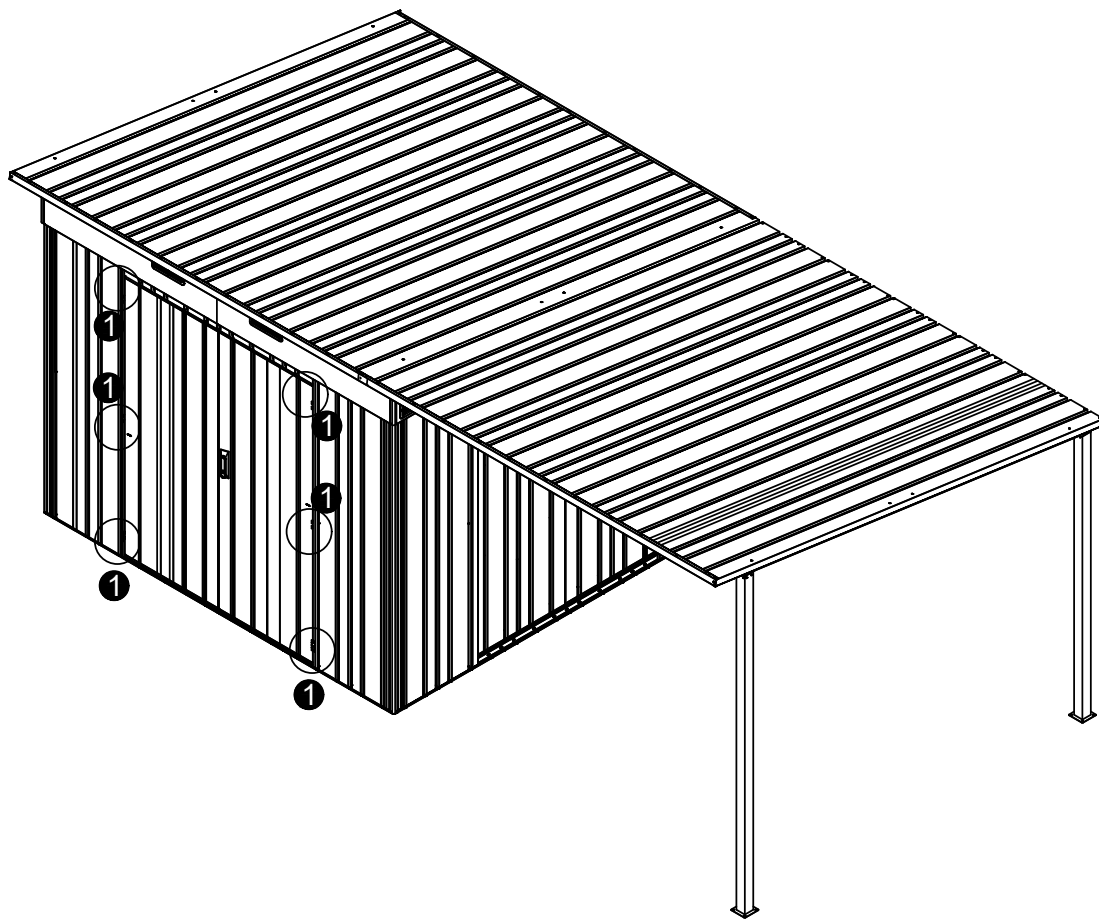

YOU CAN ADJUST THE PARALLELISM OF THE DOOR BY MOVING 2C003/2C004 LEFT OR RIGHT USING THESE SIX SCREWS · PUEDE AJUSTAR EL PARALELISMO DE LA PUERTA MOVIENDO 2C003/2C004 A LA IZQUIERDA O DERECHA USANDO ESTOS SEIS TORNILLOS · PODE AJUSTAR O PARALELISMO DA PORTA MOVENDO 2C003/2C004 PARA A ESQUERDA OU DIREITA USANDO ESTES SEIS PARAFUSOS · VOUS POUVEZ RÉGLER LE PARALLÉLISME DE LA PORTE EN DÉPLAÇANT 2C003/2C004 VERS LA GAUCHE OU LA DROITE À L'AIDE DE CES SIX VIS · SIE KÖNNEN DIE PARALLELITÄT DER TÜR EINSTELLEN, INDEM SIE 2C003/2C004 MIT DIESEN SECHS SCHRAUBEN NACH LINKS ODER RECHTS VERSCHIEBEN · ΜΠΟΡΕΙΤΕ ΝΑ ΡΥΘΜΙΣΕΤΕ ΤΗΝ ΠΑΡΑΛΛΗΛΙΣΜΟ ΤΗΣ ΠΟΡΤΑΣ ΜΕΤΑΚΙΝΩΝΤΑΣ ΤΟ 2C003/2C004 ΑΡΙΣΤΕΡΑ Η ΔΕΞΙΑ ΧΡΗΣΙΜΟΠΟΙΩΝΤΑΣ ΑΥΤΕΣ ΤΙΣ ΕΞΙ ΒΙΒΕΣ · È POSSIBILE REGOLARE IL PARALLELISMO DELLA PORTA SPOSTANDO 2C003/2C004 A SINISTRA O A DESTRA UTILIZZANDO QUESTE SEI VITI · PARALELNOST DVERI MŮZETE NASTAVIT POSUNUTÍM 2C003/2C004 DOĽAVA ALEBO DOPRAVA POMOČOU TYCHTO ŠESTIČH SKRUTIEK · PARALELNOST DVERÍ MŮZETE NASTAVIT POSUNUTÍM 2C003/2C004 DOLEVA NEBO DOPRAVA POMOČÍ TĚCHTO ŠESTI ŠROUBŮ · VZPŮREDNOST VRAT LAHKO NASTAVITE TAKO, DA S TEMI ŠESTIMI VIJAKI PREMAKNETE 2C003/2C004 LEVO ALI DESNO · DU KAN JUSTERA DÖRRENS PARALLELITET GENOM ATT FLYTTA 2C003/2C004 AT VÄNSTER ELLER HÖGER MED DESSA SEX SKRUVAR · BU ALTI VIDAYI KULLANARAK 2C003/2C004'U SOLA VEVA SAĞA HAREKET ETTIREREK KAPININ PARALELİĞİNİ AYARLAYABİLİRSİNİZ · MUND TĚ RREGULLONI PARALELİZMIN E DERĚS DUKE LĚVIZUR 2C003/2C004 MAJTAS OSE D JATHTAS DUKE PĚRDORUR KĚTO G JASHĚ VIDA · ВЪ МОЖЕТЕ ОТРЕГУЛИРОВАТЬ ПАРАЛЛЕЛЬНОСТЬ ДВЕРИ, ПЕРЕМЕЩАЯ 2C003/2C004 ВЛЕВО ИЛИ ВПРАВО С ПОМОЩЬЮ ЭТИХ ШЕСТИ ВИНТОВ · MOŻNA WYREGULOWAĆ RÓWNOLEGŁOŚĆ DRZWI, PRZESUWAJĄC 2C003/2C004 W LEWO LUB W PRAWO ZA POMOCĄ TYCH SZESTU ŚRUB · AZ AJTÓ PÁRHUZAMOSSÁGÁT A 2C003/2C004 BALRA VAGY JOBBRA MOZGATÁSÁVAL ÁLLÍTHATJA BE EZEN HAT CSAVAR SEGÍTSÉGEVEL

