



Y20 | 1,14m<sup>2</sup>

Caseta de jardín · Arrumação exterior · Abri de jardin Gerätehaus  
Σπιτάκι · Záhradné domčeky · Vrtne kućice · Zahradní domek  
Vrtne hišice · Trädgårdsbod · Bahçe kulübesi



USER'S MANUAL · MANUAL DE INSTRUCCIONES · MANUAL DE INSTRUÇÕES  
MANUEL D'INSTRUCTIONS · GEBRAUCHSANWEISUNG · ΕΓΧΕΙΡΙΔΙΟ ΧΡΗΣΤΗ  
MANUALE DI ISTRUZIONI · NÁVOD NA POUŽITIE · PRIRUČNIK · NÁVOD K POUŽITÍ  
NAVODILA ZA UPORABO · INSTRUKTIONSHANDBOK · KULLANIM KILAVUZU





# INDEX

Índice - Inhaltsverzeichnis - Indice - Kazalo - Innehåll - İçindekiler

EN		<b>User's manual</b> .....	04
ES		<b>Manual de instrucciones</b> .....	05
PT		<b>Manual de instruções</b> .....	06
FR		<b>Manuel d'instructions</b> .....	07
DE		<b>Gebrauchsanweisung</b> .....	08
EL		<b>Εγχειρίδιο χρήστη</b> .....	09
IT		<b>Manuale di istruzioni</b> .....	10
SK		<b>Návod na použitie</b> .....	11
HR		<b>Priručnik</b> .....	12
CS		<b>Návod k použití</b> .....	13
SL		<b>Navodila za uporabo</b> .....	14
SV		<b>Bruksanvisning</b> .....	15
TR		<b>Kullanım kılavuzu</b> .....	16
		<b>Assembly - Montaje - Montagem -Montage</b> <b>Συναρμολόγηση - Montaggio - Montáž - Montaža</b> <b>Montering - Montaj</b> .....	17

# USER'S MANUAL

*Before we begin...*

**We want to thank you for choosing one of our products. The assembly process may require a little patience and time, but don't worry, we are here to encourage you! 😊**

Once you are finished think of the satisfaction and pride you will feel when you see your finished work and know that you have done it yourself. Also, by assembling it you are making a contribution to the environment. How? As it is not delivered fully assembled, less packaging is used, which means less waste and less waste. In this way each product takes up less space and therefore you make the most of the means of transport, thus reducing CO<sub>2</sub> emissions.

Therefore, with this purchase you are making a conscious choice to protect our planet.

*So, go ahead and get to work!*



**Two people are required to assemble the product**



**The average assembly time can be between 2 hours for the smaller models and 10-12 hours for the larger ones**

## **RECOMMENDATIONS PRIOR TO ASSEMBLY**

The product is not designed to be installed directly on the lawn. We recommend assembly on a level and firm wooden base, a flat concrete floor or cemented bricks or blocks.

If a concrete pad is made it is important that it is sloped towards the edges to prevent water ingress.

It is very important to fix the product to the floor. It does not include screws or other parts necessary for anchoring.

## **MAINTENANCE**

The roof must be kept free of debris, as the weight on top can damage your product.

Do not store chemical, combustible and/or corrosive products inside.

## **WARRANTY**

This product is manufactured with the best materials and under strict quality controls and standards. If you detect any problem with the product you have purchased, please contact our customer service department at the telephone number and email address given on the back cover of this instruction manual.

The warranty is valid from the date of purchase shown on the receipt or invoice, which must be presented to make use of the warranty.

The warranty period for this product varies depending on the legal regulations applicable in the country of purchase. Please refer to the regulations in force in the country of purchase for more information.

## **EXCLUDED FROM THE WARRANTY:**

There are certain causes that are excluded from the warranty such as:

- > If there is a transport non-conformity, the transport agency must be notified within 24 hours of delivery.
- > Breakage or damage caused by inclement weather.
- > Incorrect assembly, incorrect use and consequences derived from this.

In addition, you can consult the complete list of these three by scanning the QR on the box.

**TOOLS REQUIRED FOR ASSEMBLY**

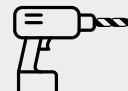

# MANUAL DE INSTRUCCIONES

Antes de comenzar...

**Queremos agradecerte que hayas elegido uno de nuestros productos. El proceso de montaje puede requerir un poco de paciencia y tiempo, pero no te preocupes ¡estamos aquí para animarte! 😊**

Una vez que termines piensa en la satisfacción y orgullo que sentirás al ver tu trabajo terminado y saber que lo has hecho tú mismo. Además, al montarlo estás haciendo una contribución al medio ambiente. ¿Cómo? Al no ser entregado completamente armado, se utiliza menos embalaje, lo que significa menos residuos y menos desperdicio. De esta manera cada producto ocupa menos espacio y por lo tanto se aprovecha al máximo los medios de transporte reduciendo de esta manera las emisiones de CO<sub>2</sub>.

Por lo tanto, con esta compra estás haciendo una elección consciente para proteger nuestro planeta.

*Ahora sí... ¡Adelante y manos a la obra!*



Son necesarias dos personas para el montaje del producto



El tiempo medio de montaje puede estar entre las 2h de los modelos más pequeños a las 10-12h de los más grandes

## RECOMENDACIONES PREVIAS AL MONTAJE

El producto no está diseñado para ser instalada directamente sobre el césped. Recomendamos el montaje sobre una base nivelada y firme de madera, un suelo llano de cemento o ladrillos o bloques cementados.

Si se hace una plataforma de cemento es importante que se incline hacia los bordes para evitar la entrada de agua. Es muy importante fijar el producto al suelo. No incluye tornillos ni otras piezas necesarias para su anclaje.

## MANTENIMIENTO

El techo debe mantenerse limpio de residuos, ya que el peso en la parte superior puede deteriorar tu producto. No guarde productos químicos, combustibles y/o corrosivos en su interior.

## GARANTÍA

Este producto está fabricado con los mejores materiales y bajo estrictos controles y estándares de calidad. En caso de detectar algún inconveniente en el producto adquirido, rogamos te pongas en contacto con el servicio de atención al cliente en el teléfono y email que aparecen descritos en la contraportada de este manual de instrucciones.

La garantía es válida a partir de compra que aparece en el ticket o factura, el cual deberá presentarse para hacer uso de la garantía.

El periodo de garantía de este producto varía en función de la normativa legal aplicable en el país de compra. Consulte la normativa vigente del país para más información.

## QUEDAN EXCLUIDAS DE LA GARANTÍA:

Hay ciertas causas que quedan excluidas de la garantía como:

- > Si existe una no conformidad del transporte, hay que comunicárselo a la agencia de transportes antes de que transcurran 24h desde la entrega.
- > Las roturas o daños generados por inclemencias meteorológicas.
- > El mal montaje, uso incorrecto y consecuencias derivadas de ello.

Además, de estas tres puedes consultar la lista completa en escaneando el QR de la caja.

**HERRAMIENTAS  
NECESARIAS PARA  
SU MONTAJE**



# MANUAL DE INSTRUÇÕES

Antes de começarmos...

**Queremos agradecer-lhe por ter escolhido um dos nossos produtos. O processo de montagem pode exigir um pouco de paciência e tempo, mas não se preocupe, estamos aqui para o encorajar! 😊**

Quando terminar, pense na satisfação e no orgulho que sentirá quando vir o seu trabalho acabado e souber que foi feito por si. Além disso, ao montá-lo, está a contribuir para o ambiente. Como? Como não é entregue totalmente montado, é utilizada menos embalagem, o que significa menos resíduos e menos desperdício. Desta forma, cada produto ocupa menos espaço e, portanto, aproveita-se ao máximo os meios de transporte, reduzindo assim as emissões de CO<sub>2</sub>.

Portanto, com esta compra, está a fazer uma escolha consciente para proteger o nosso planeta.

*Por isso, ponha mãos à obra!*



São necessárias duas pessoas para montar o produto



O tempo médio de montagem pode ser de 2 horas para os modelos mais pequenos e de 10 a 12 horas para os modelos maiores

## RECOMENDAÇÕES ANTES DA MONTAGEM

O produto não foi concebido para ser instalado diretamente no relvado. Aconselhamos a montagem sobre uma base de madeira nivelada e firme, sobre um chão de betão plano ou sobre tijolos ou blocos cimentados.

Se for feita uma base de betão, é importante que esta seja inclinada para os bordos para evitar a entrada de água.

É muito importante fixar o produto ao chão. Não inclui parafusos ou outras peças necessárias para a fixação.

## MANUTENÇÃO

O teto deve ser mantido livre de detritos, uma vez que o peso no topo pode danificar o seu produto.

Não guardar produtos químicos, combustíveis e/ou corrosivos no interior.

## GARANTIA

Este produto é fabricado com os melhores materiais e sob rigorosos controlos e normas de qualidade. Se detetar algum problema com o produto que adquiriu, contacte o nosso serviço de apoio ao cliente através do número de telefone e do endereço de correio eletrónico indicados na contracapa do presente manual de instruções.

A garantia é válida a partir da data de compra indicada no recibo ou na fatura, que deve ser apresentada para fazer uso da garantia.

O período de garantia deste produto varia consoante os regulamentos legais aplicáveis no país de compra. Para mais informações, consultar a regulamentação em vigor no país de compra.

## EXCLUÍDOS DA GARANTIA:

Existem determinadas causas que estão excluídas da garantia, tais como:

- > Em caso de não conformidade de transporte, a entidade transportadora deve ser notificada no prazo de 24 horas após a entrega.
- > Quebra ou danos causados por intempéries.
- > Montagem incorrecta, utilização incorrecta e consequências daí resultantes.

Para além disso, pode consultar a lista completa destas três advertências através da leitura do QR na caixa.

**FERRAMENTAS  
NECESSÁRIAS  
PARA A MONTAGEM**



# MANUEL D'INSTRUCTIONS

Avant de commencer...

**Nous tenons à vous remercier d'avoir choisi l'un de nos produits. Le processus d'assemblage peut nécessiter un peu de patience et de temps, mais ne vous inquiétez pas, nous sommes là pour vous encourager ! 😊**

Une fois que vous aurez terminé, pensez à la satisfaction et à la fierté que vous éprouverez en voyant votre travail terminé et en sachant que vous l'avez fait vous-même. De plus, en l'assemblant, vous contribuez à la protection de l'environnement. Comment ? Comme il n'est pas livré entièrement assemblé, moins d'emballage est utilisé, ce qui signifie moins de déchets et moins de gaspillage. De cette manière, chaque produit prend moins de place et vous exploitez au maximum les moyens de transport, réduisant ainsi les émissions de CO<sub>2</sub>.

Avec cet achat, vous faites donc un choix conscient pour protéger notre planète.

*Alors, n'hésitez plus et mettez-vous au travail !*



Deux personnes sont nécessaires pour assembler le produit



Le temps de montage moyen peut être de 2 heures pour les petits modèles et de 10 à 12 heures pour les plus grands

## RECOMMANDATIONS AVANT L'ASSEMBLAGE

Le produit n'est pas conçu pour être installé directement sur la pelouse. Nous recommandons de l'assembler sur une base en bois plane et ferme, sur un sol plat en béton ou sur des briques ou des blocs cimentés.

Si un socle en béton est réalisé, il est important qu'il soit incliné vers les bords afin d'éviter les infiltrations d'eau.

Il est très important de fixer le produit au sol. Les vis et autres éléments nécessaires à l'ancrage ne sont pas inclus.

## ENTRETIEN

Le toit doit être maintenu exempt de débris, car le poids qui s'y trouve peut endommager votre produit.

Ne pas stocker de produits chimiques, combustibles et/ou corrosifs à l'intérieur.

## GARANTIE

Ce produit est fabriqué avec les meilleurs matériaux et selon des normes et des contrôles de qualité stricts. Si vous constatez un problème quelconque avec le produit que vous avez acheté, veuillez contacter notre service clientèle au numéro de téléphone et à l'adresse électronique indiqués au dos de ce manuel d'instructions.

La garantie est valable à partir de la date d'achat indiquée sur le ticket de caisse ou la facture, qui doivent être présentés pour bénéficier de la garantie.

La période de garantie de ce produit varie en fonction des dispositions légales applicables dans le pays d'achat. Pour plus d'informations, veuillez vous référer à la réglementation en vigueur dans le pays d'achat.

## EXCLUS DE LA GARANTIE:

Certaines causes sont exclues de la garantie:

- > En cas de non-conformité du transport, l'agence de transport doit être informée dans les 24 heures suivant la livraison.
- > Casse ou dommages causés par les intempéries.
- > Un montage incorrect, une utilisation incorrecte et les conséquences qui en découlent.

En outre, vous pouvez consulter la liste complète de ces trois éléments en scannant le QR sur la boîte.

**OUTILS  
NÉCESSAIRES À  
L'ASSEMBLAGE**



# GEBRAUCHSANWEISUNG

*Bevor wir beginnen...*

**Wir möchten Ihnen danken, dass Sie sich für eines unserer Produkte entschieden haben. Der Zusammenbau kann ein wenig Geduld und Zeit erfordern, aber keine Sorge, wir sind hier, um Sie zu unterstützen! 😊**

Wenn Sie fertig sind, denken Sie an die Zufriedenheit und den Stolz, den Sie empfinden werden, wenn Sie Ihr fertiges Werk sehen und wissen, dass Sie es selbst gemacht haben. Außerdem leisten Sie durch den Zusammenbau einen Beitrag zum Umweltschutz: Da das Produkt nicht komplett zusammengebaut geliefert wird, wird weniger Verpackung verwendet, was wiederum weniger Abfall bedeutet. Auf diese Weise nimmt jedes Produkt weniger Platz ein, und Sie nutzen die Transportmittel optimal aus, wodurch der CO<sub>2</sub>-Ausstoß verringert wird.

Mit diesem Kauf treffen Sie also eine bewusste Entscheidung für den Schutz unseres Planeten.

*Und jetzt... an die Arbeit!*



**Für den Zusammenbau des Produkts werden zwei Personen benötigt**



**Die durchschnittliche Montagezeit kann zwischen 2 Stunden für die kleineren Modelle und 10-12 Stunden für die größeren Modelle liegen**

## 🗨 EMPFEHLUNGEN VOR DER MONTAGE

Das Produkt ist nicht für die direkte Montage auf dem Rasen vorgesehen. Wir empfehlen die Montage auf einer ebenen und festen Holzunterlage, einem flachen Betonboden oder zementierten Ziegeln oder Blöcken.

Bei einer Betonunterlage ist es wichtig, dass sie zu den Kanten hin abgeschrägt ist, um das Eindringen von Wasser zu verhindern. Es ist sehr wichtig, das Produkt auf dem Boden zu befestigen. Schrauben oder andere für die Verankerung notwendige Teile sind nicht im Lieferumfang enthalten.

## 🔧 WARTUNG

Das Dach muss frei von Ablagerungen gehalten werden, da das Gewicht auf dem Dach Ihr Produkt beschädigen kann. Lagern Sie keine chemischen, brennbaren und/oder ätzenden Produkte im Inneren.

## 🛡 GARANTIE

Dieses Produkt wird mit den besten Materialien und unter strengen Qualitätskontrollen und -standards hergestellt. Sollten Sie ein Problem mit dem von Ihnen erworbenen Produkt feststellen, wenden Sie sich bitte an unseren Kundendienst unter der auf der Rückseite dieser Bedienungsanleitung angegebenen Telefonnummer und E-Mail-Adresse.

Die Garantie gilt ab dem Kaufdatum, das auf der Quittung oder Rechnung angegeben ist, die zur Inanspruchnahme der Garantie vorgelegt werden muss.

Die Garantiezeit für dieses Produkt variiert je nach den gesetzlichen Bestimmungen des Landes, in dem es gekauft wurde. Bitte informieren Sie sich über die im Land des Kaufs geltenden Vorschriften.

## ⚠ VON DER GARANTIE AUSGESCHLOSSEN:

Es gibt bestimmte Ursachen, die von der Garantie ausgeschlossen sind, wie z. B.:

- > Im Falle eines Transportfehlers muss das Transportunternehmen innerhalb von 24 Stunden nach der Lieferung benachrichtigt werden.
- > Bruch oder Beschädigung durch schlechtes Wetter.
- > Fehlerhafte Montage, unsachgemäße Verwendung und daraus resultierende Folgen.

Darüber hinaus können Sie die vollständige Liste dieser drei Punkte durch Scannen des QR-Codes auf der Verpackung einsehen.

**FÜR DIE MONTAGE  
ERFORDERLICHE  
WERKZEUGE**

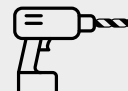



# ΕΓΧΕΙΡΙΔΙΟ ΧΡΗΣΤΗ

Πριν ξεκινήσουμε...

**Θέλουμε να σας ευχαριστήσουμε που επιλέξατε ένα από τα προϊόντα μας. Η διαδικασία συναρμολόγησης μπορεί να απαιτεί λίγη υπομονή και χρόνο, αλλά μην ανησυχείτε, είμαστε εδώ για να σας ενθαρρύνουμε! 😊**

Μόλις τελειώσετε σκεφτείτε την ικανοποίηση και την υπερηφάνεια που θα νιώσετε όταν θα δείτε το τελικό σας έργο και θα ξέρετε ότι το κάνατε μόνοι σας. Επίσης, με τη συναρμολόγησή του συμβάλλετε στο περιβάλλον. Πώς; Καθώς δεν παραδίδεται πλήρως συναρμολογημένο, χρησιμοποιείται λιγότερη συσκευασία, πράγμα που σημαίνει λιγότερα απορρίμματα και λιγότερα απόβλητα. Με αυτόν τον τρόπο κάθε προϊόν καταλαμβάνει λιγότερο χώρο και επομένως αξιοποιείτε στο έπακρο τα μέσα μεταφοράς, μειώνοντας έτσι τις εκπομπές CO<sub>2</sub>.

Επομένως, με αυτή την αγορά κάνετε μια συνειδητή επιλογή για την προστασία του πλανήτη μας.

*Προχωρήστε λοιπόν και πιάστε δουλειά!*



Για τη συναρμολόγηση του προϊόντος απαιτούνται δύο άτομα



Ο μέσος χρόνος συναρμολόγησης μπορεί να κυμαίνεται μεταξύ 2 ωρών για τα μικρότερα μοντέλα και 10-12 ωρών για τα μεγαλύτερα

## 🗨 ΣΥΣΤΑΣΕΙΣ ΠΡΙΝ ΑΠΟ ΤΗ ΣΥΝΑΡΜΟΛΟΓΗΣΗ

Το προϊόν δεν έχει σχεδιαστεί για να εγκατασταθεί απευθείας στο γκαζόν. Συνιστούμε τη συναρμολόγηση σε επίπεδη και σταθερή ξύλινη βάση, σε επίπεδο τσιμεντένιο δάπεδο ή σε τσιμεντοποιημένα τούβλα ή τούβλα.

Εάν γίνει μια τσιμεντένια βάση, είναι σημαντικό να έχει κλίση προς τις άκρες για να αποφευχθεί η εισροή νερού.

Είναι πολύ σημαντικό να στερεωθεί το προϊόν στο δάπεδο. Δεν περιλαμβάνονται βίδες ή άλλα μέρη που είναι απαραίτητα για την αγκύρωση.

## 🔑 ΣΥΝΤΗΡΗΣΗ

Η οροφή πρέπει να διατηρείται απαλλαγμένη από σκουπίδια, καθώς το βάρος στην κορυφή μπορεί να προκαλέσει ζημιά στο προϊόν σας.

Μην αποθηκεύετε χημικά, εύφλεκτα ή/και διαβρωτικά προϊόντα στο εσωτερικό της.

## ⚙ ΕΓΓΥΗΣΗ

Αυτό το προϊόν κατασκευάζεται με τα καλύτερα υλικά και κάτω από αυστηρούς ποιοτικούς ελέγχους και πρότυπα. Εάν εντοπίσετε οποιοδήποτε πρόβλημα με το προϊόν που αγοράσατε, παρακαλούμε επικοινωνήστε με το τμήμα εξυπηρέτησης πελατών μας στον αριθμό τηλεφώνου και στη διεύθυνση ηλεκτρονικού ταχυδρομείου που αναγράφονται στο οπισθόφυλλο του παρόντος εγχειριδίου οδηγιών χρήσης.

Η εγγύηση ισχύει από την ημερομηνία αγοράς που αναγράφεται στην απόδειξη ή το τιμολόγιο, τα οποία πρέπει να προσκομιστούν για να κάνετε χρήση της εγγύησης.

Η περίοδος εγγύησης για αυτό το προϊόν ποικίλλει ανάλογα με τους νομικούς κανονισμούς που ισχύουν στη χώρα αγοράς. Για περισσότερες πληροφορίες ανατρέξτε στους κανονισμούς που ισχύουν στη χώρα αγοράς.

## ⚙ ΕΞΑΙΡΟΥΝΤΑΙ ΑΠΟ ΤΗΝ ΕΓΓΥΗΣΗ:

Υπάρχουν ορισμένες αιτίες που εξαιρούνται από την εγγύηση, όπως:

- > Εάν υπάρχει μη συμμόρφωση κατά τη μεταφορά, το πρακτορείο μεταφοράς πρέπει να ειδοποιηθεί εντός 24 ωρών από την παράδοση.
- > Σπάσιμο ή ζημιά που προκαλείται από κακές καιρικές συνθήκες.
- > Λανθασμένη συναρμολόγηση, λανθασμένη χρήση και συνέπειες που απορρέουν από αυτήν.

Επιπλέον, μπορείτε να συμβουλευτείτε τον πλήρη κατάλογο αυτών των τριών, σαρώνοντας το QR στο κουτί.

**ΕΡΓΑΛΕΙΑ ΠΟΥ ΑΠΑΙΤΟΥΝΤΑΙ ΓΙΑ ΤΗ ΣΥΝΑΡΜΟΛΟΓΗΣΗ**

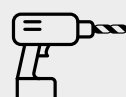

# MANUALE DI ISTRUZIONI

*Prima di iniziare...*

**Vogliamo ringraziarvi per aver scelto uno dei nostri prodotti. Il processo di assemblaggio può richiedere un po' di pazienza e di tempo, ma non preoccupatevi, siamo qui per incoraggiarvi! 😊**

Una volta terminato, pensate alla soddisfazione e all'orgoglio che proverete quando vedrete il vostro lavoro finito e saprete di averlo fatto da soli. Inoltre, assemblandolo, darete un contributo all'ambiente: poiché non viene consegnato completamente assemblato, vengono utilizzati meno imballaggi, il che significa meno rifiuti e meno scarti. In questo modo ogni prodotto occupa meno spazio e quindi si sfruttano al meglio i mezzi di trasporto, riducendo così le emissioni di CO<sub>2</sub>. Pertanto, con questo acquisto fate una scelta consapevole per proteggere il nostro pianeta.

Quindi, andate avanti e mettetevi al lavoro!



Per assemblare il prodotto sono necessarie due persone



Il tempo medio di montaggio può variare da 2 ore per i modelli più piccoli a 10-12 ore per quelli più grandi

## 🗨️ RACCOMANDAZIONI PRIMA DEL MONTAGGIO

Il prodotto non è stato progettato per essere installato direttamente sul prato. Si consiglia il montaggio su una base di legno piana e solida, su un pavimento di cemento piatto o su mattoni o blocchi cementati.

Se si realizza una base in cemento, è importante che sia inclinata verso i bordi per evitare l'ingresso di acqua.

È molto importante fissare il prodotto al suolo. Non sono incluse viti o altre parti necessarie per l'ancoraggio.

## 🔧 MANUTENZIONE

Il tetto deve essere mantenuto libero da detriti, poiché il peso sulla parte superiore può danneggiare il prodotto.

Non conservare all'interno prodotti chimici, combustibili e/o corrosivi.

## 🛡️ GARANZIA

Questo prodotto è realizzato con i migliori materiali e in base a rigorosi controlli e standard di qualità. Se si riscontrano problemi con il prodotto acquistato, si prega di contattare il servizio clienti al numero di telefono e all'indirizzo e-mail riportati sul retro della copertina di questo manuale di istruzioni.

La garanzia è valida a partire dalla data di acquisto riportata sullo scontrino o sulla fattura, che deve essere presentata per usufruire della garanzia.

Il periodo di garanzia per questo prodotto varia a seconda delle norme legali applicabili nel paese di acquisto. Per maggiori informazioni, consultare le norme vigenti nel Paese di acquisto.

## ⚠️ ESCLUSE DALLA GARANZIA:

Vi sono alcune cause che sono escluse dalla garanzia, come ad esempio:

- > In caso di non conformità al trasporto, l'agenzia di trasporto deve essere informata entro 24 ore dalla consegna.
- > Rotture o danni causati da intemperie.
- > Montaggio non corretto, uso non corretto e conseguenze derivanti da questo.

Inoltre, è possibile consultare l'elenco completo di questi tre elementi scansionando il QR sulla scatola.

**STRUMENTI  
NECESSARI PER IL  
MONTAGGIO**



# NÁVOD NA POUŽITIE

*Predtým, ako začneme...*

**Ďakujeme za kúpu jedného z našich produktov. Proces montáže môže vyžadovať trochu trpezlivosti a času, no my sme tu na to, aby sme vám s tým pomohli! 😊**

Myslíte na uspokojenie a pýchu, ktorú pocítite pri pohľade na vlastnoručne dokončenú prácu. Navyše, montážou pomáhate životnému prostrediu. Ako? Dodanie čiastočne rozloženého produktu vyžaduje menej obalového materiálu a menej odpadu. Týmto spôsobom sa obmedzuje aj veľkosť produktov, a tým sa prispieva k úplnému využitiu priestoru v dopravných prostriedkoch a zníženiu CO<sub>2</sub>.

Táto kúpa reprezentuje vašu uvedomelú voľbu na ochranu planéty.

*Teraz sa už môžete pustiť do práce!*



Na montáž produktu sú potrebné dve osoby



Čas montáže sa pohybuje medzi 2 hodinami, v prípade malých modelov, a 10 – 12 hodinami pri najväčších produktoch

## ODPORÚČANIA PRED ZAČATÍM MONTÁŽE

Výrobok nie je určený na inštaláciu priamo na trávnik. Odporúčame montáž na rovnú a pevný drevený podklad, rovnú podlahu z betónu, tehliel či tvárnic.

Pri stavbe betónového podkladu je dôležité jeho naklonenie smerom k okrajom, aby sa vyhlo hromadeniu vody.

Je dôležité pripevniť produkt k podkladu. Balenie neobsahuje skrutky ani iné súčiastky na jeho ukotvenie.

## ÚDRŽBA

Udržujte strechu produktu bez záťaže, pretože tá by mohla spôsobiť jej poškodenie.

Vo vnútri produktu neskladujte chemikálie, horľavé a/alebo oxidačné látky.

## ZÁRUKA

Tento produkt je vyrobený z najlepších materiálov podľa prísnych kontrol a štandardov kvality. Ak zistíte akékoľvek problémy so zakúpeným výrobkom, obráťte sa na oddelenie služieb zákazníkom na telefónnom čísle a e-mailovej adrese uvedenej na zadnej strane tohto návodu na použitie.

Záruka je platná od dátumu nákupu uvedeného na účtenke alebo faktúre, ktorú je potrebné predložiť na uplatnenie záruky. Záručná doba na tento výrobok sa líši v závislosti od právnych predpisov platných v krajine nákupu. Ďalšie informácie nájdete v právnych predpisoch príslušnej krajiny.

## SÚ ZO ZÁRUKY VYLÚČENÉ:

Existujú určité príčiny, ktoré sú zo záruky vylúčené, ako napríklad:

- > Ak sa vyskytne nehoda pri preprave, prepravná spoločnosť musí byť informovaná do 24 hodín od doručenia.
- > Rozbitie alebo poškodenie spôsobené nepriaznivým počasím.
- > Nesprávna montáž, nesprávne používanie a ich dôsledky.

Kompletný zoznam týchto prípadov si môžete pozrieť naskenovaním kódu QR na škatuli.

**NÁRADIE  
POTREBNÉ NA  
MONTÁŽ**



# PRIRUČNIK

Prije no što započnete...

**Hvala vam što ste odabrali jedan od naših proizvoda. Za proces montaže možda je potrebno nešto strpljenja i vremena, ali ne brinite se: ovdje smo da vam pomognemo! 😊**

Pomislite na zadovoljstvo i ponos koje ćete osjetiti kad završite i vidite da je vaš posao gotov i da ste ga sami napravili. Osim toga, montažom pomažete okolišu. Kako? S obzirom na to da se ne isporučuje u gotovom stanju, troši se manje ambalaže, što znači manje otpadaka i smeća. Na ovaj način svaki proizvod zauzima manje prostora, zbog čega se prijevozna sredstva maksimalno iskorištavaju, čime se smanjuje emisija CO<sub>2</sub>.

Stoga vi ovom kupnjom svjesno odlučujete zaštititi naš planet.

*A sada... Na posao!*



**Za montažu proizvoda potrebne su dvije osobe**



**Prosječno vrijeme montaže može biti od 2 h za najmanje modele do 10-12 h za najveće**

## PREPORUKE PRIJE MONTAŽE

Proizvod nije namijenjen za travnjak kao izravnu podlogu. Preporučujemo montažu na čvrstoj, ravnoj drvenoj podlozi, ravnoj betonskoj podlozi ili podlozi od cementiranih opeka ili ploča.

Ako se radi betonska platforma važno je da ona ima nagib prema rubovima kako bi se izbjegao prodor vode.

Vrlo je važno pričvrstiti proizvod za pod. Nisu uključeni vijci ni drugi dijelovi potrebni za pričvršćivanje.

## ODRŽAVANJE

Krov se mora čistiti od otpadaka jer težina u gornjem dijelu može oštetiti vaš proizvod.

Unutra nemojte skladištiti kemijske, zapaljive i/ili korozivne proizvode.

## JAMSTVO

Ovaj proizvod izrađen je od vrhunskih materijala i pod strogim kontrolama i standardima kvalitete. U slučaju bilo kakvih mana na kupljenom proizvodu, obratite se službi za kupce na broj telefona i e-mail koji su navedeni na poledini ovog priručnika za uporabu.

Jamstvo vrijedi od datuma kupnje koji se nalazi na potvrdi ili računu koji je potrebno predložiti za korištenje jamstva.

Razdoblje jamstva za ovaj proizvod varira ovisno o zakonskim propisima koji su na snazi u zemlji kupnje. Za više informacija proučite važeće propise.

## U JAMSTVO NISU UKLJUČENI:

Neki uzroci nisu uključeni u jamstvo, kao:

- > U slučaju neadekvatnog transporta, treba obavijestiti agenciju za prijevoz prije no što prođu 24 sata od isporuke.
- > Lomovi ili oštećenja uzrokovani vremenskim nepogodama.
- > Loša montaža, nepravilna uporaba i njihove posljedice.

Osim ova tri, možete pregledati cijeli popis skeniranjem QR koda na kutiji.

**ALAT POTREBAN  
ZA MONTAŽU**

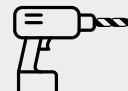

# NÁVOD K POUŽITÍ

Než začnete...

**Chtěli bychom vám poděkovat, že jste si vybrali jeden z našich produktů. Montáž může vyžadovat trochu trpělivosti a času, ale nebojte se, jsme tu, abychom vám pomohli! 😊**

Představte si, jaké uspokojení a hrdost pocítíte, až uvidíte produkt smontovaný a budete vědět, že jste jej smontovali vy sami. Navíc tím šetříte i životní prostředí. Proč? Díky tomu, že produkty nejsou dodávány kompletně smontované, spotřebovává se méně obalů, což znamená méně odpadu a zbytků. Každý výrobek tak zabírá méně místa a proto se dopravní prostředky maximálně využijí, čímž se snižují emise CO<sub>2</sub>.

Tímto nákupem se tedy vědomě rozhodujete chránit naši planetu.

*Tak a nyní... Jdeme na to!*



K sestavení produktu jsou zapotřebí dvě osoby



Průměrná doba montáže může být 2 hodiny u nejmenších modelů a 10-12 hodin u největších

## **DOPORUČENÍ PŘED MONTÁŽÍ**

Výrobek není určen k instalaci přímo na trávník. Doporučujeme jej umístit na pevný a rovný dřevěný podklad, rovnou cementovou podlahu nebo tmelené cihly či bloky.

Pokud se jedná o cementovou plošinu, je důležité, aby se svažovala směrem k okrajům, aby se zabránilo vniknutí vody. Je velmi důležité připevnit výrobek k zemi. Neobsahuje šrouby ani jiné díly nutné k jeho ukotvení.

## **ÚDRŽBA**

Na střeše nesmí zůstat žádné předměty, protože její zatížení by mohlo poškodit váš produkt. Neskladujte uvnitř chemické, hořlavé ani korozivní produkty.

## **ZÁRUKA**

Tento produkt je vyroben z nejlepších materiálů a byl podroben přísné kontrole kvality a norem. V případě, že u zakoupeného produktu zjistíte jakékoliv závady, kontaktujte prosím zákaznický servis na telefonním čísle a emailu, které jsou uvedeny na zadní straně tohoto návodu.

Záruka je platná od data nákupu uvedeného na stvrzence nebo faktuře, kterou je nutné předložit pro její uplatnění.

Záruční doba pro tento výrobek se liší v závislosti na právních předpisech platných v zemi nákupu. Další informace naleznete v aktuálních předpisech dané země.

## **ZÁRUKA SE NEUPLATŇUJE V NÁSLEDUJÍCÍCH PŘÍPADECH:**

Existují určité případy, kdy záruku nelze uplatnit, například:

- > V případě, že nejste spokojeni s přepravou, je nutné tuto skutečnost oznámit přepravní kanceláři do 24 hodin od doručení.
- > Při rozbití nebo poškození způsobeného nepřízní počasí
- > V případě špatného provedení montáže, nesprávného použití a z toho vyplývajících důsledků.

Kromě těchto tří důvodů existují další, jejichž kompletní seznam si můžete přečíst po naskenování QR kódu na krabici.

**NÁŘADÍ POTŘEBNÉ  
K MONTÁŽÍ**



# NAVODILA ZA UPORABO

*Pred začetkom...*

**Želimo se vam zahvaliti, ker ste izbrali enega od naših izdelkov. Postopek montaže bo morda zahteval nekaj potrpljenja in časa, a ne skrbite, tukaj smo, da vam pomagamo! 😊**

Ko končate z montažo, pomislite na zadovoljstvo in ponos, ki ju boste občutili, ko boste videli svoje delo dokončali in vse naredili sami. Poleg tega z montažo pozitivno prispevate k okolju. Kako? Ker izdelek ni dostavljen popolnoma montiran, se porabi manj embalaže, kar pomeni manj ostankov in manj odpadkov. Na ta način vsak izdelek zasede manj prostora in je zato prevozno sredstvo kar se da izkoriščeno, s čimer se zmanjšajo emisije CO<sub>2</sub>.

Zato ste se s tem nakupom zavestno odločili za zaščito našega planeta.

*Zdaj pa ... Kar na delo!*



Za montažo izdelka sta potrebni dve osebi



Povprečni čas montaže je lahko med 2 urama za manjše modele in 10-12 ur za največje modele

## PRIPOROČILA PRED MONTAŽO

Izdelek ni zasnovan za namestitvev neposredno na trato. Priporočamo, da se montaža opravi na trdni, ravni leseni podlagi, ravnih cementnih tleh ali na cementiranih opekah ali blokih.

Če se izdelka cementna ploščad, je pomembno, da je nagnjena proti robovom, da se prepreči udor vode.

Zelo pomembno je, da izdelek pritrдите na tla. Ne vključuje vijakov ali drugih delov, potrebnih za njegovo pritrđitev.

## VZDRŽEVANJE

Na strehi ne sme biti ostankov, saj lahko njihova teža uniči vaš izdelek.

V notranjosti ne shranjujte kemičnih, gorljivih in/ali jedkih izdelkov.

## GARANCIJA

Ta izdelek je narejen iz najboljših materialov ter pod strogimi nadzori in standardi glede kakovosti. V primeru, da pri kupljenem izdelku zaznate kakršne koli nevesčnosti, se obrnite na službo za pomoč strankam ter pokličite na telefonsko številko ali pišite na e-poštni naslov, ki sta navedena na zadnji platnici teh navodil za uporabo.

Garancija velja od datuma nakupa, ki je naveden na računu, ki ga morate predložiti za uveljavljanje garancije.

Garancijska doba za ta izdelek se razlikuje glede na pravne predpise, ki veljajo v državi nakupa. Za več informacij si oglejte trenutne predpise v državi nakupa.

## IZ GARANCIJE JE IZVZETO NASLEDNJE:

Obstajajo določeni vzroki, ki so izključeni iz garancije, kot so:

- > Če pride do neskladij pri prevozu, je treba o tem obvestiti prevoznika v 24 urah po dostavi izdelka.
- > Zlomi ali poškodbe zaradi neugodnih vremenskih razmer
- > Slaba montaža, nepravilna uporaba in posledice, ki izhajajo iz tega.

Poleg teh treh vzrokov si lahko ogledate celoten seznam tako, da skenirate kodo QR na škatli.

**ORODJE,  
POTREBNO ZA  
MONTAŽO**



# BRUKSANVISNING

Innan du börjar...

**Vi vill tacka dig för att du valt en av våra produkter. Monteringsprocessen kan kräva lite tålamod och tid, men oroa dig inte, vi är här för att heja på dig! 😊**

När du är klar, tänk på tillfredsställelsen och stoltheten du kommer att känna när du ser ditt färdiga arbete och veta att du gjorde det själv. Dessutom bidrar du till miljön genom att ställa in den. Som? Genom att inte levereras färdigmonterad går det åt mindre förpackningar, vilket innebär mindre avfall och mindre förstörelse. På så sätt tar varje produkt upp mindre utrymme, vilket maximerar användningen av transportresurser och därigenom minskar CO<sub>2</sub>-utsläppen.

Därför gör du med detta köp ett medvetet val för att skydda vår planet.

*Nu ja... Varsågod och börja jobba!*



**Två personer krävs  
för att montera  
produkten**



**Den genomsnittliga monterings tiden  
kan vara mellan 2 timmar för de minsta  
modellerna och 10-12 timmar för de största**

## REKOMMENDATIONER FÖRE MONTERING

Produkten är inte konstruerad för att installeras direkt på gräsmattan. Vi rekommenderar montering på en jämn och fast träbotten, ett plant golv av cement eller cementerade tegel eller block.

Om en betongplattform byggs är det viktigt att den sluttar mot kanterna för att förhindra att vatten kommer in.

Det är mycket viktigt att säkra produkten till marken. Det inkluderar inte skruvar eller andra delar som behövs för förankring.

## UNDERHÅLL

Taket bör hållas fritt från skräp, eftersom vikten ovanpå kan skada din produkt.

Förvara inte kemikalier, bränslen och/eller frätande ämnen inuti.

## GARANTI

Denna produkt är tillverkad med de finaste materialen och under strikta kvalitetskontroller och standarder. Om du märker några problem med den köpta produkten, vänligen kontakta kundtjänst på telefonnumret och e-postadressen som anges på baksidan av denna bruksanvisning.

Garantin gäller från inköpsdatumet som visas på kvittot eller fakturan, som måste visas upp för att göra anspråk på garantin.

Garantiperioden för denna produkt varierar beroende på de lagliga regler som gäller i inköpslandet. Se ditt lands aktuella bestämmelser för mer information.

## FÖLJANDE ÄR EXKLUDERADE FRÅN GARANTIN:

Det finns vissa orsaker som är uteslutna från garantin som:

- > Om det finns en avvikelse i transporten ska det meddelas transportverket före kl. 24 timmar har gått sedan leverans.
- > Sprickor eller skador orsakade av dåligt väder.
- > Dålig montering, felaktig användning och konsekvenser till följd av detta.

Dessutom kan du kontrollera hela listan över dessa tre genom att skanna QR-koden på rutan.

**VERKTYG BEHÖVS  
FÖR MONTERING**



# KULLANIM KILAVUZU

*Başlamadan önce...*

**Ürünlerimizden birini tercih ettiğiniz için teşekkür ederiz. Montaj süreci biraz sabır ve zaman gerektirebilir, ama endişelenmeyin, sizi desteklemek için buradayız! 😊**

İşiniz bittiğinde, bitmiş işinizi gördüğünüzde ve bunu kendiniz yaptığınızı bildiğinizde hissedeceğiniz memnuniyeti ve gururu düşünün. Ayrıca bunu kurarak çevreye de katkıda bulunuyorsunuz. Gibi? Tamamen monte edilmiş halde teslim edilmemesi sayesinde daha az ambalaj kullanılıyor, bu da daha az atık ve bozulma anlamına geliyor. Bu sayede her ürün daha az yer kaplıyor, ulaşım kaynaklarının en iyi şekilde kullanılması sağlanıyor, dolayısıyla CO2 emisyonu azalıyor.

Dolayısıyla bu alışverişinizle gezegenimizi korumak adına bilinçli bir tercihte bulunuyorsunuz.

*Evet şimdi... Hadi, işe koyul!*



Ürünün montajı için iki kişiye ihtiyaç vardır.



En küçük modellerde ortalama montaj süresi 2 saat, en büyük modellerde ise 10-12 saat arasında değişebiliyor.

## 🗨 MONTAJ ÖNCESİ ÖNERİLER

Ürün doğrudan çimlerin üzerine monte edilmek üzere tasarlanmamıştır. Bir montaj öneriyoruz düz ve sağlam ahşap taban, çimento veya çimentolu tuğla veya bloklardan yapılmış düz bir zemin.

Beton bir platform inşa edilecekse, suyun içeri girmesini önlemek için kenarlara doğru eğimli olması önemlidir.

Ürünün zemine sabitlenmesi çok önemlidir. İçerisinde sabitleme için gerekli vida ve diğer parçalar bulunmamaktadır.

## 🔧 BAKIM

Çatı, ürününüze zarar verebileceğinden, molozlardan temiz tutulmalıdır.

İçerisinde kimyasal, yakıt ve/veya aşındırıcı maddeler saklamayın.

## 🛡 GARANTİSİ

Bu ürün en iyi malzemelerle, sıkı kalite kontrolleri ve standartları altında üretilmiştir. Satın aldığınız üründe herhangi bir sorun fark ederseniz, lütfen bu kullanım kılavuzunun arka kapağında belirtilen telefon numarası ve e-posta adresinden müşteri hizmetleriyle iletişime geçin.

Garanti, garantiyi talep etmek için ibraz edilmesi gereken fiş veya faturada belirtilen satın alma tarihinden itibaren geçerlidir.

Bu ürünün garanti süresi, satın alındığı ülkede geçerli olan yasal düzenlemelere bağlı olarak değişiklik göstermektedir.

Daha fazla bilgi için lütfen ülkenizin geçerli yönetmeliklerine bakın.

## ⚠ KG AŞAĞIDAKİLER GARANTİ DIŞINDADIR:

Garanti kapsamı dışında kalan bazı nedenler şunlardır:

- > Taşımada bir uygunsuzluk varsa, taşıma acentesine önceden bildirilmelidir. Teslimatın üzerinden 24 saat geçti.
- > Olumsuz hava koşullarından kaynaklanan kırılmalar veya hasarlar.
- > Kötü montaj, yanlış kullanım ve bundan kaynaklanan sonuçlar.

Ayrıca kutunun üzerindeki QR kodunu taratarak bu ürünün tam listesini görebilirsiniz.



**MONTAJ İÇİN  
GEREKLİ ARAÇLAR**









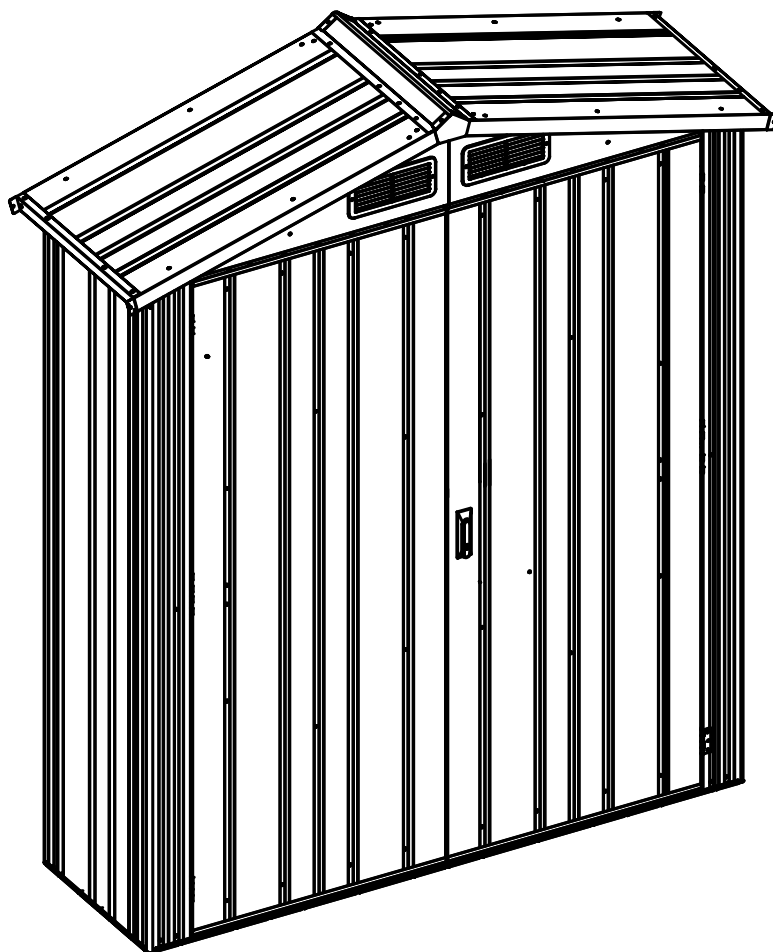

**ASSEMBLY · MONTAJE · MONTAGEM · MONTAGE · ΣΥΝΑΡΜΟΛΟΓΗΣΗ**  
**MONTAGGIO · MONTÁŽ · MONTAŽA · MONTERING · MONTAJ**

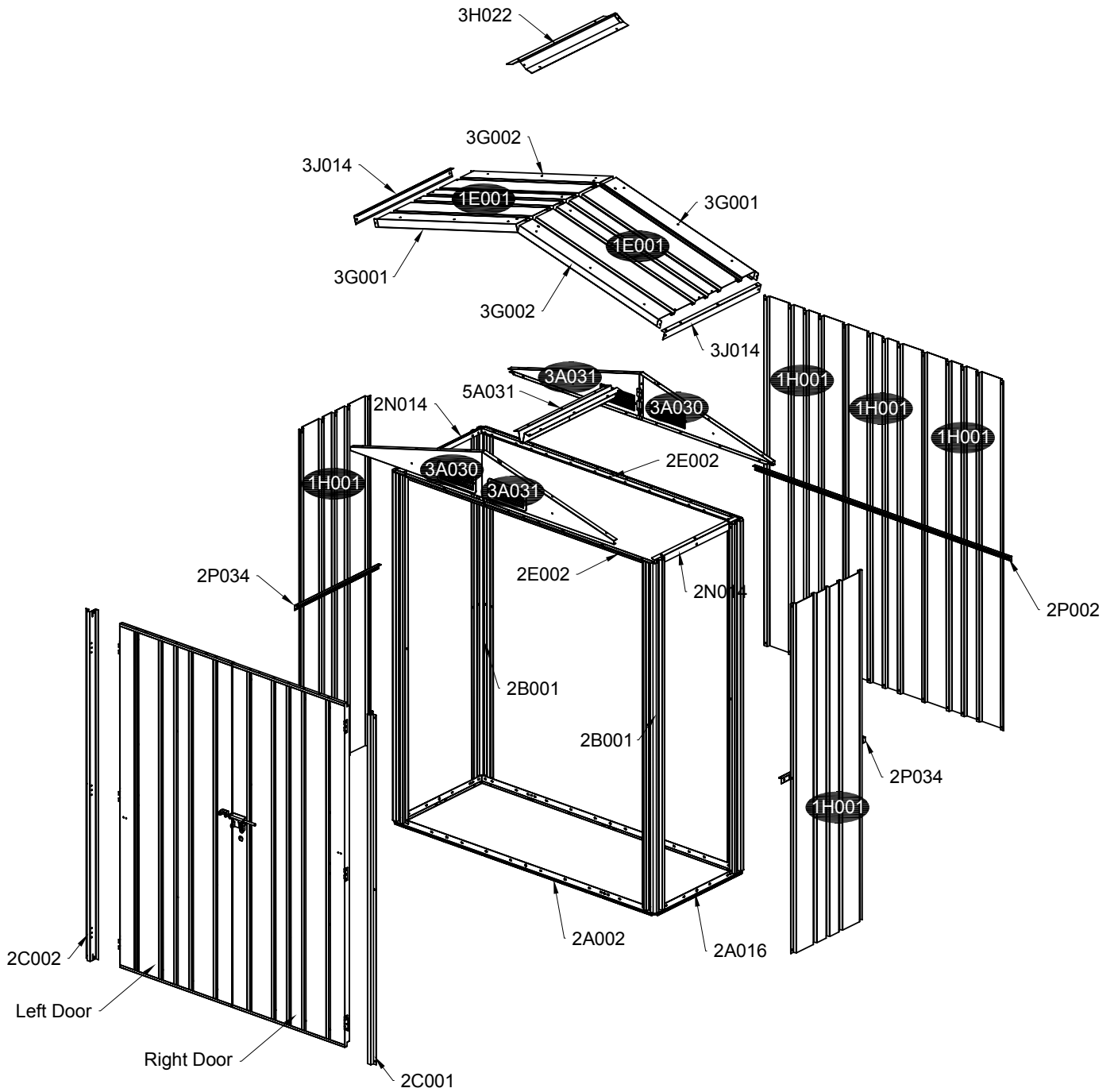
---

	<p><b>Máx.</b> <b>60 Kg/m<sup>2</sup></b></p> 	<p><b>Máx.</b> <b>100 km/h</b></p> 	<p>El techo debe mantenerse limpio de residuos, como hojas caídas o nieve / The roof should be kept clean from debris, such as fallen leaves or snow / Le toit doit être maintenu propre des débris, tels que les feuilles tombées ou la neige / O telhado deve ser mantido limpo de detritos, como folhas caídas ou neve / Das Dach sollte frei von Ablagerungen wie Laub oder Schnee gehalten werden / Το ταπότριο πρέπει να διατηρείται καθαρό από κλαδιά, φύλλα ή χιόνι / Il tetto deve essere tenuto pulito da detriti, come foglie cadute o neve / Streha mora ostati čista pred ostanki, kot so padlo listje ali sneg / Strecha by mala zostať čistá od nečistôt, ako sú opadané listy alebo sneh / Krov bi trebao ostati čist od otpada, kao što su opalo lišće ili snijeg / Strecha musí byť čistá od nečistôt, jako je spadane listi nebo snih</p>
---	---	--	--



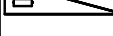





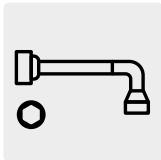
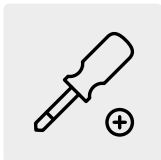







































PART	NO	QTY
	1H001	5
	1E001	2
	1G001	2
	3A030	2
	3A031	2

▼  
TOOLS  
PROVIDED



PART	NO	QTY
	D353	2
	D354	12
	D398	2
	D438	4
	H170	6
	H127	45
	A112	1
	H147	2
	S63 M4X12	10
	S74 M4X8	237
	S75 M4X10	36
	M08 M5	2
	M25 M4	270
	J156	12
	Z40 M5X40	12

	PART	NO	QTY
1		4A021	1
		4A014	1
		2E002	2
		2N014	2
		2P034	2
		2P002	1
		2R001	4
	3J014	2	
2		3G001	2
		4B001	2
3		3G002	2
		4B001	2
4		2A016	2
		2A002	2
		4A002	2
		4C001	1
5		2B001	4
6		2C001	1
		2C002	1
		5A031	1
7		3H022	1

PART	NO	QTY
	1G001	1
	4A002	1
	4A014	1
	4B001	2
	2R001	2
	H170	3
	H147	2
	M08	2
	M5	

**LEFT DOOR** · PUERTA IZQUIERDA · PORTA ESQUERDA · PORTE GAUCHE · LINKE TÜR · ΑΡΙΣΤΕΡΗ ΠΟΡΤΑ · PORTA SINISTRA · LAVÉ DVERE · LIJEVA VRATA · LEVÉ DVERĚ · LEVA VRATA · VÄNSTER DÖRR · SOL KAPI

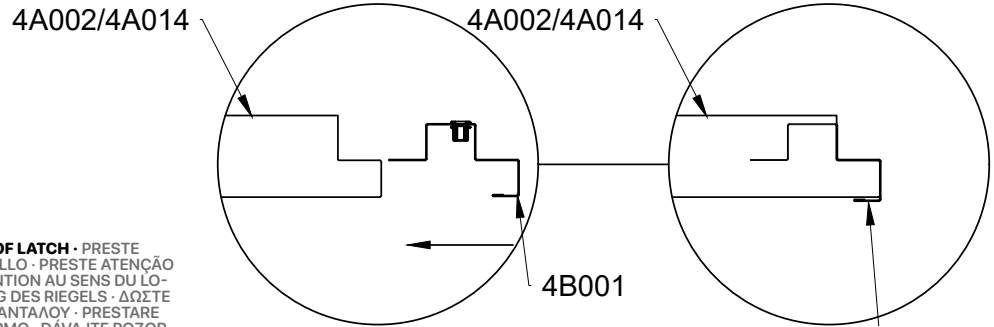
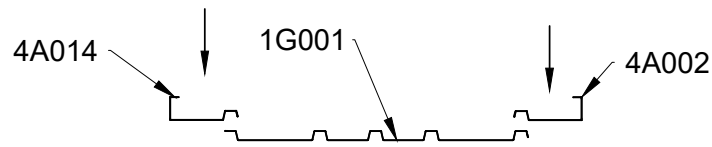



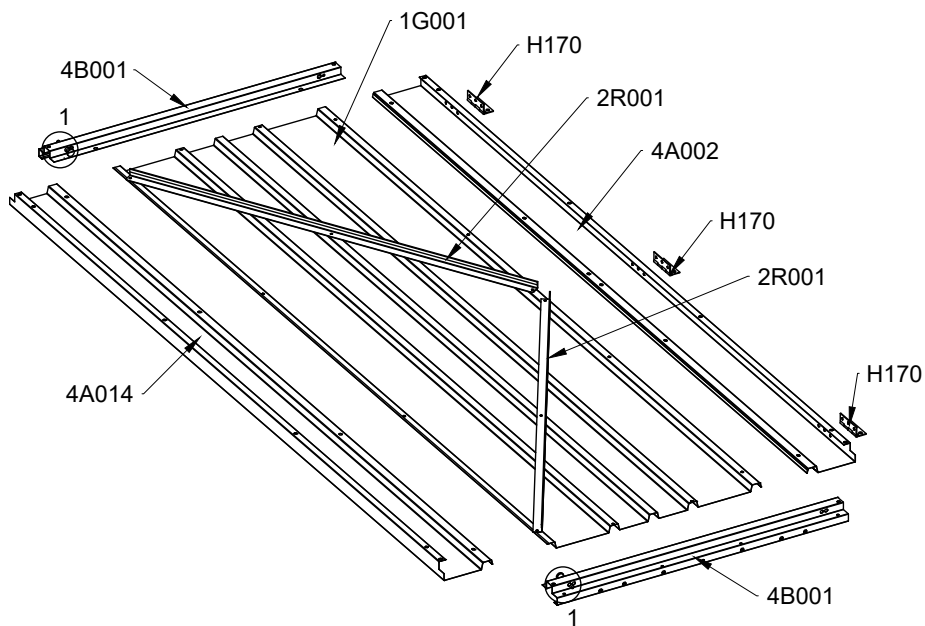

**PAY ATTENTION TO THE DIRECTION OF LATCH** · PRESTE ATENCIÓN A LA DIRECCIÓN DEL PESTILLO · PRESTE ATENÇÃO NA DIREÇÃO DA TRAVA · FAITES ATTENTION AU SENS DU LOQUET · ACHTEN SIE AUF DIE RICHTUNG DES RIEGELS · ΔΩΣΤΕ ΠΡΟΣΟΧΗ ΣΤΗΝ ΚΑΤΕΥΘΥΝΣΗ ΤΟΥ ΜΑΝΤΑΛΟΥ · PRESTARE ATTENZIONE ALLA DIREZIONE DEL FERMO · DÁVAJTE POZOR NA SMER ZÁPADKY · OBRATITE POZORNOST NA SMJER ZASUNA · VĚNUJTE POZORNOST SMĚRU ZÁPADKY · BODITE POZORNÍ NA SMER ZAPAHA · VAR UPPMÄRKSAM PÅ SPÄRRENS RIKTNING · VAR UPPMÄRKSAM PÅ SPÄRRENS RIKTNING

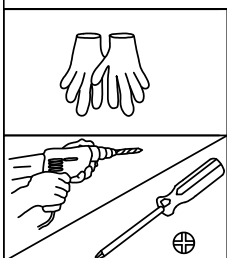
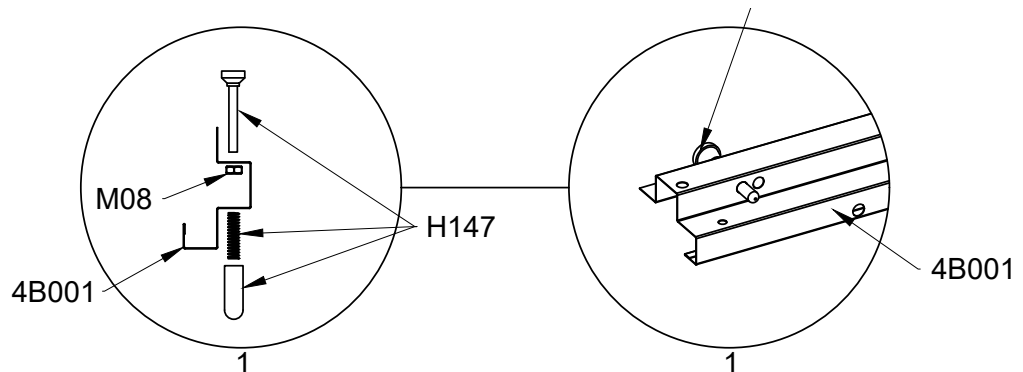





**RIGHT DOOR NO LATCH** · PUERTA DERECHA NO PESTILLO · PORTA DIREITA SEM TRINCO · PORTE DROITE PAS DE LOQUET · RECHTE TÜR OHNE RIEGEL · ΔΕΞΙΑ ΠΟΡΤΑ ΧΩΡΙΣ ΣΥΡΤΗ · PORTA DESTRA SENZA SERRATURA · PRÁVÉ DVERĚ BEZ ZÁPADKY · DESNA VRATA BEZ ZASUNA · PRÁVÉ DVERĚ BEZ ZÁPADKY · DESNA VRATA BREZ ZAPAHA · HÖGER DÖRR INGEN SPÄRR · SAĞ KAPI MANDALI YOK

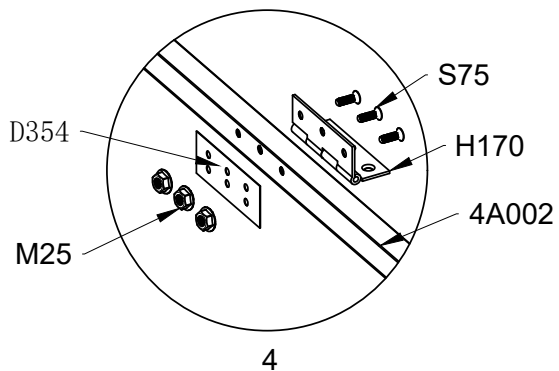
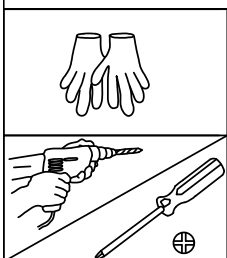
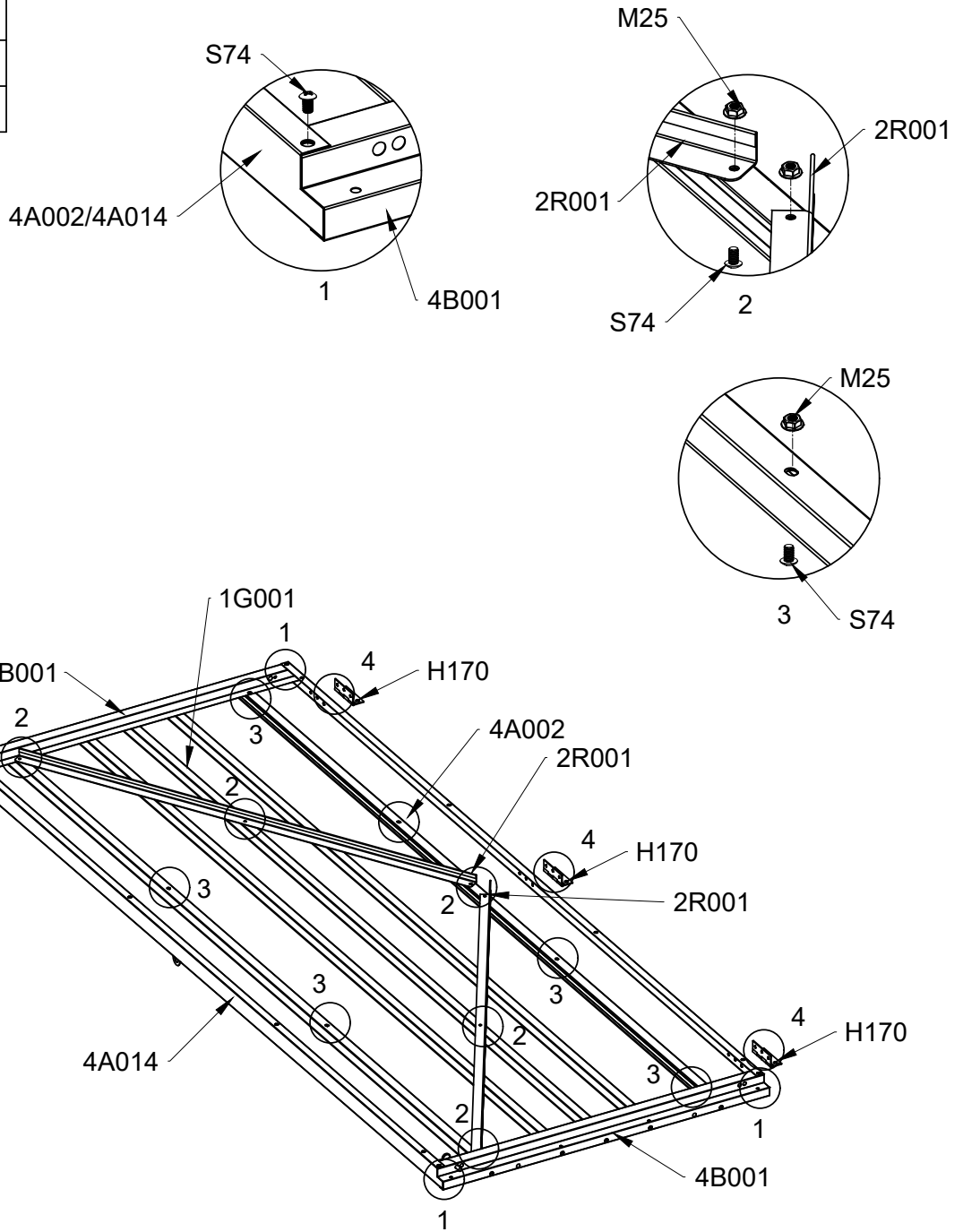

PART	NO	QTY
	D354	3
	S74	25
	M4X8	
	S75	9
	M4X10	
	M25	30
	M4	

LEFT DOOR · PUERTA IZQUIERDA · PORTA ESQUERDA · PORTE GAUCHE · LINKE TÜR · ΑΡΙΣΤΕΡΗ ΠΟΡΤΑ · PORTA SINISTRA · LAVÉ DVERE · LIJEVA VRATA · LEVÉ DVERĚ · LEVA VRATA · VÄNSTER DÖRR · SOL KAPI







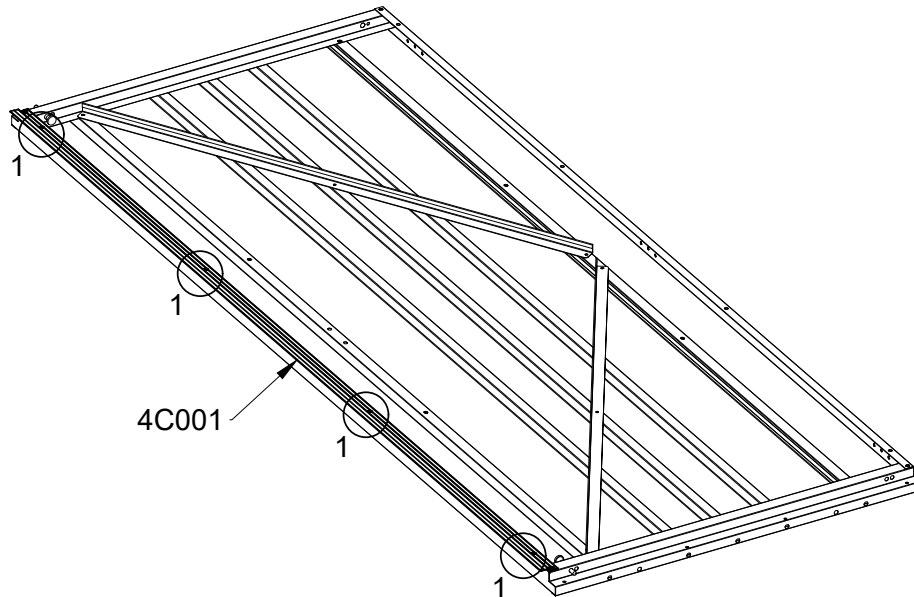

PART	NO	QTY
	4C001	1
	S74	4
	M4X8	
	M25	4
	M4	

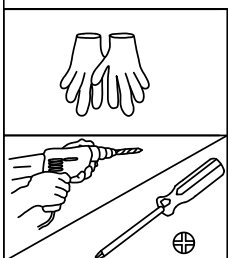
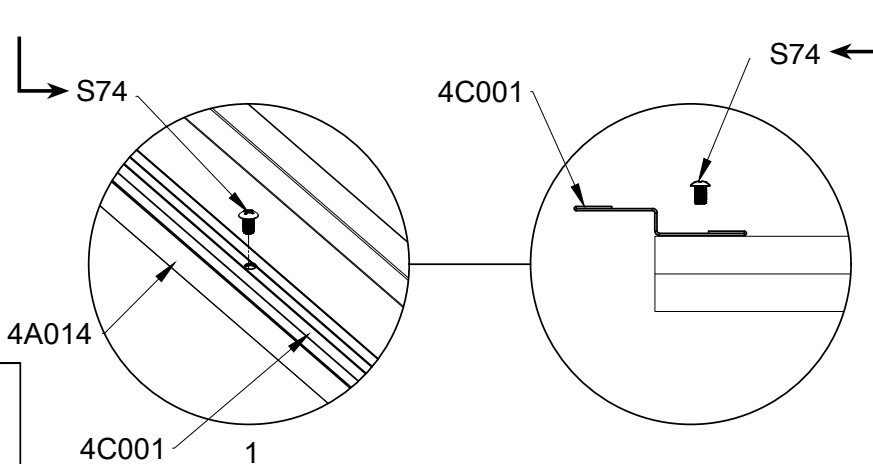
**LEFT DOOR** · PUERTA IZQUIERDA · PORTA ESQUERDA · PORTE GAUCHE · LINKE TÜR · ΑΡΙΣΤΕΡΗ ΠΟΡΤΑ · PORTA SINISTRA · L'AVÉ DVERE · LIJEVA VRATA · LEVÉ DVERĚ · LEVA VRATA · VÄNSTER DÖRR · SOL KAPI







**USE M25 INSIDE** · UTILIZAR M25 EN EL INTERIOR · UTILIZAR A M25 NO INTERIOR · UTILISER M25 À L'INTÉRIEUR · VERWENDEN SIE INNEN M25 · ΧΡΗΣΙΜΟΠΟΙΗΣΤΕ ΤΟ Μ25 ΜΕΣΑ · USA M25 ALL'INTERNO · VNÚTRÍ POUŽÍTE M25 · KORISTITE M25 UNUTRA · UVNITŘ POUŽIJTE M25 · UPORABITE M25 ZNOTRAJ · ANVÄND M25 INUTI

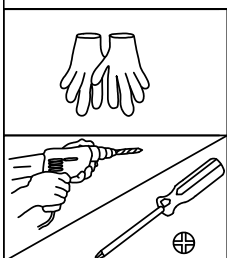
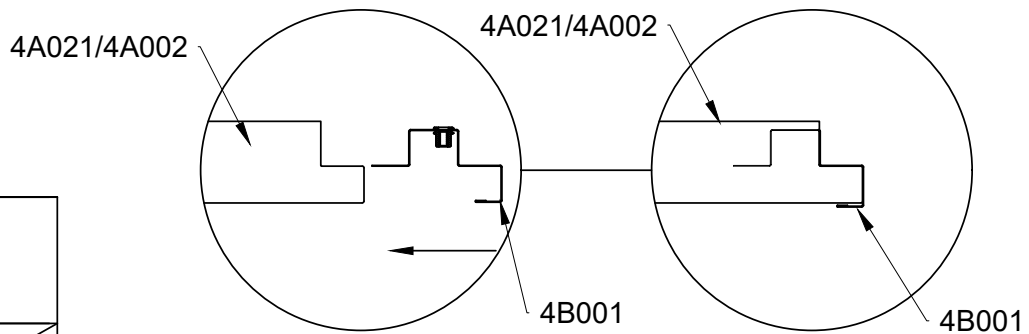
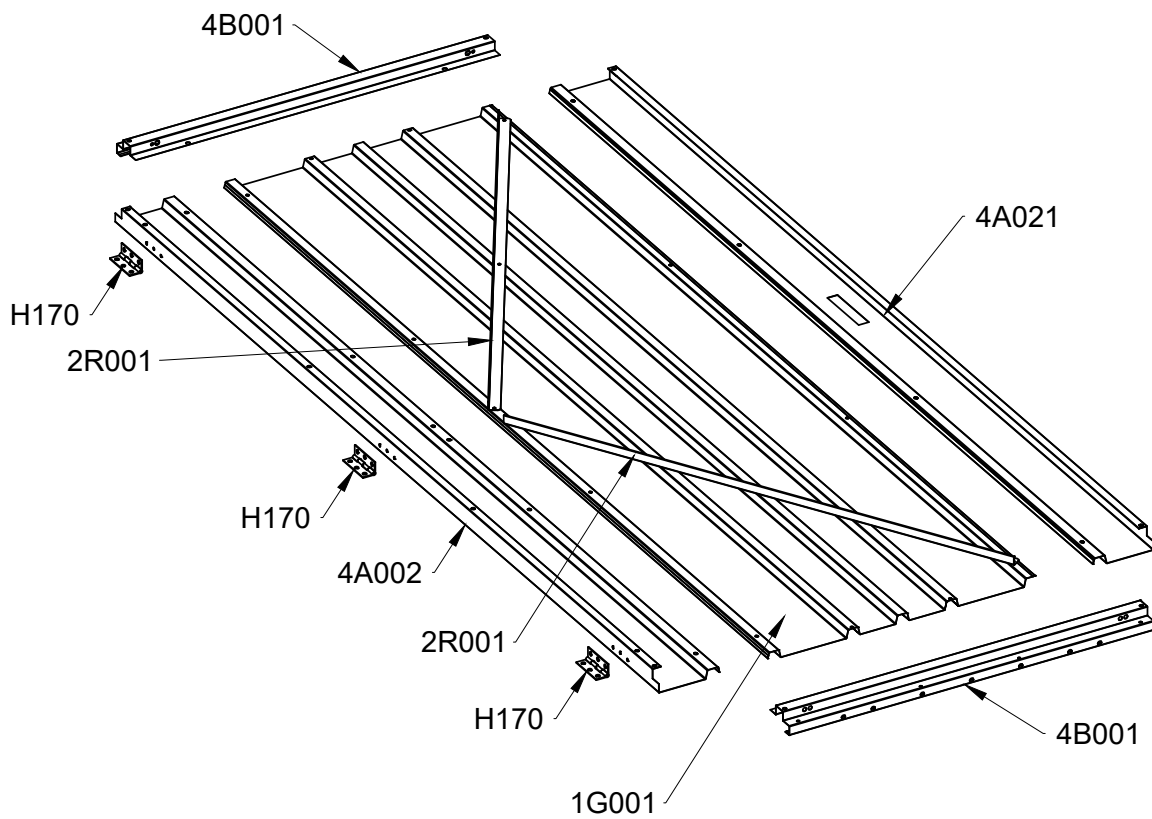
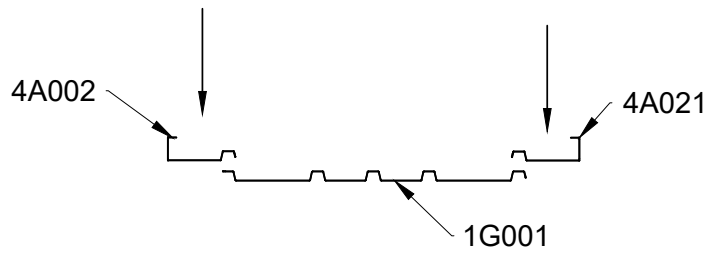

PART	NO	QTY
	1G001	1
	4A021	1
	4A002	1
	4B001	2
	2R001	2
	H170	3

**RIGHT DOOR** · PUERTA DERECHA · PORTA DIREITA · PORTE DROITE · RECHTE TÜR · ΔΕΞΙΑ ΠΟΡΤΑ · PORTA DESTRA · PRAVÉ DVERĚ · DESNA VRATA · PRAVÉ DVERĚ · DESNA VRATA · HÖGER DÖRR · SAĞ KAPI





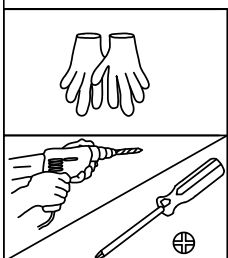
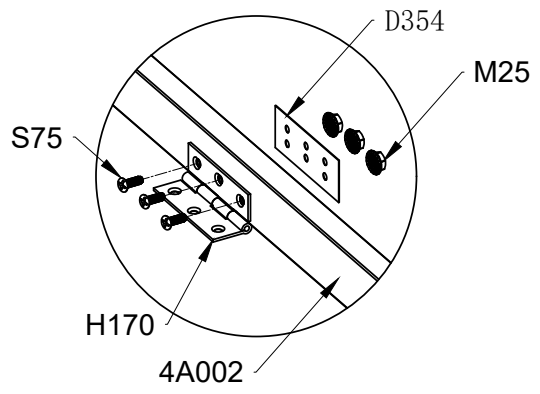
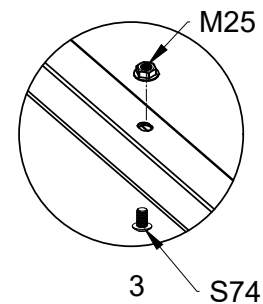
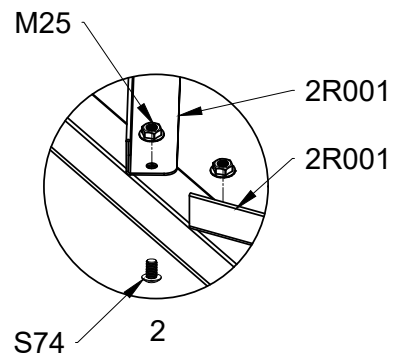
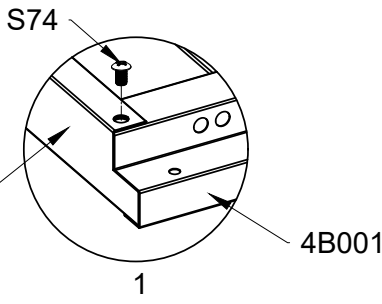
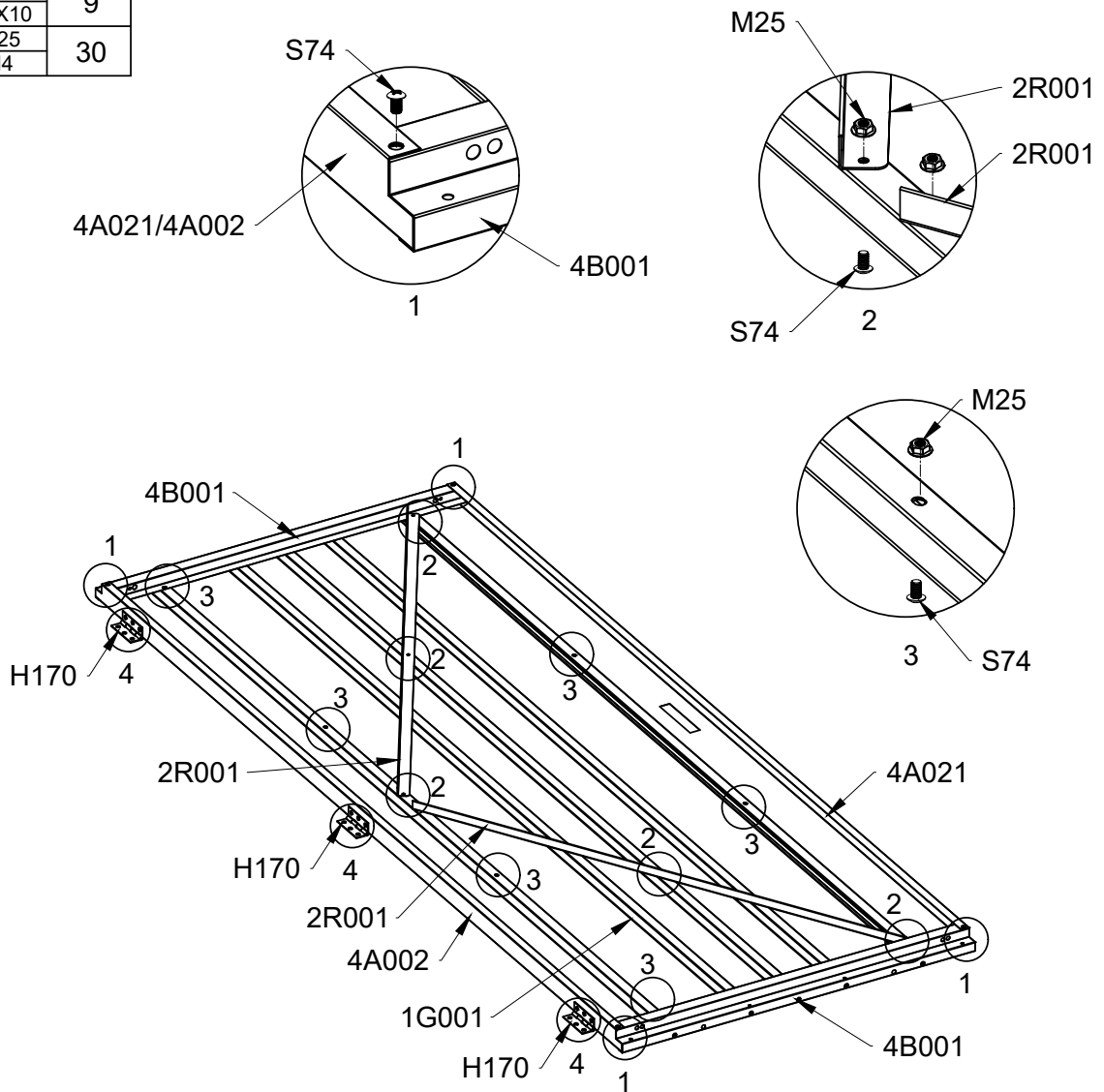

PART	NO	QTY
	D354	3
	S74	25
	M4X8	
	S75	9
	M4X10	
	M25	30
	M4	



RIGHT DOOR · PUERTA DERECHA · PORTA DIREITA · PORTE DROITE · RECHTE TÜR · ΔΕΞΙΑ ΠΟΡΤΑ · PORTA DESTRA · PRAVÉ DVĚŘE · DESNA VRATA · PRAVÉ DVĚŘE · DESNA VRATA · HÖGER DÖRR · SAĞ KAPI





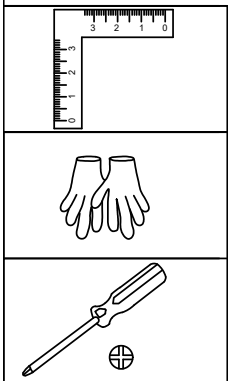
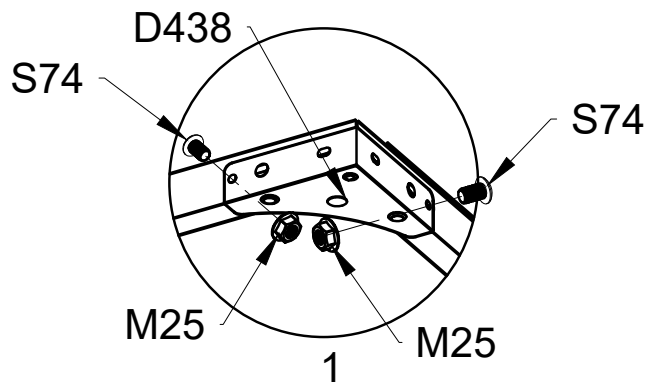
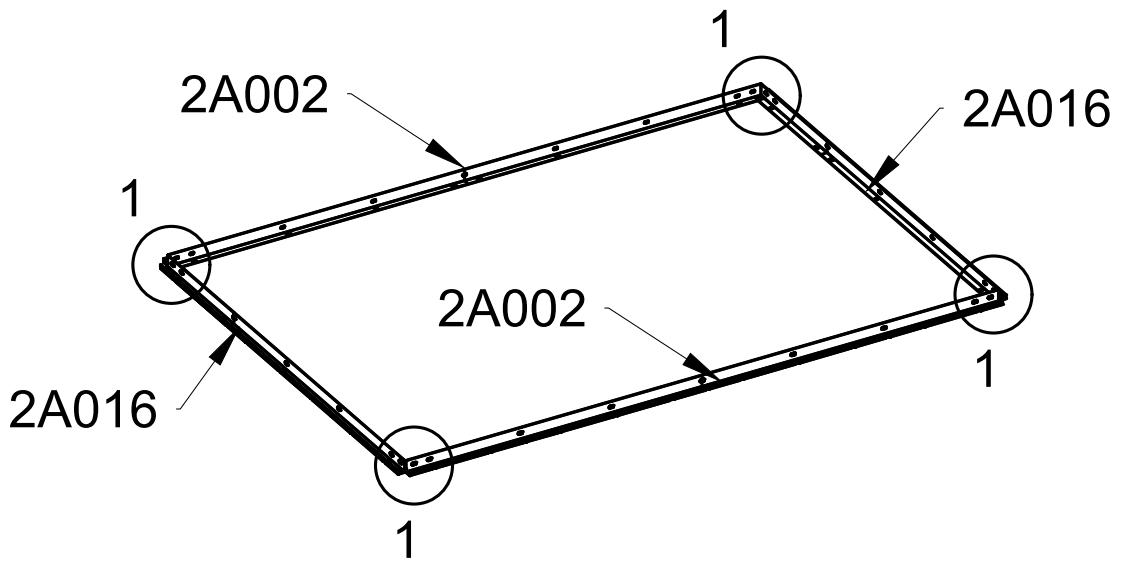



PART	NO	QTY
	2A016	2
	2A002	2
	D438	4
	S74	8
	M4X8	
	M25	8
	M4	

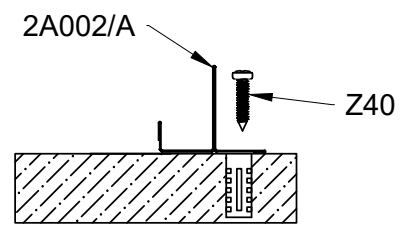
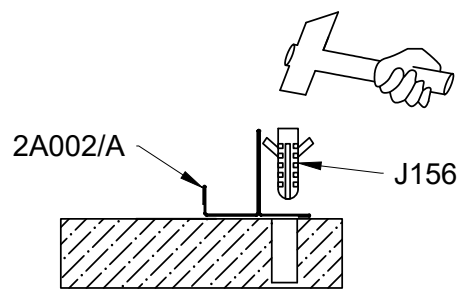
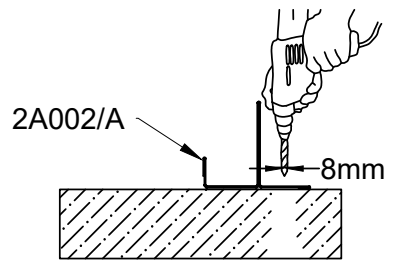
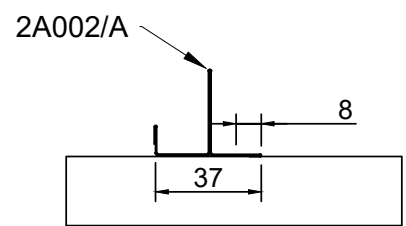
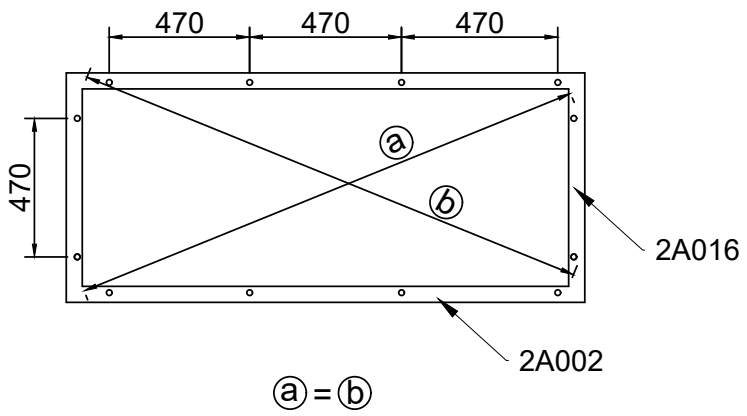





PART	NO	QTY
	J156	12
	Z40	12
	M5X40	

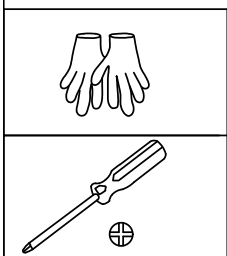
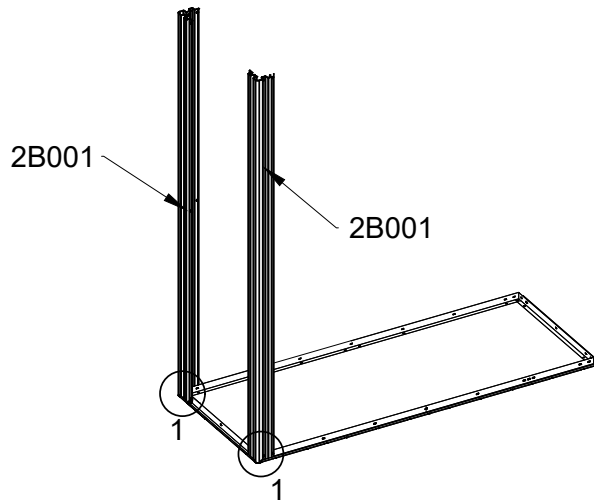
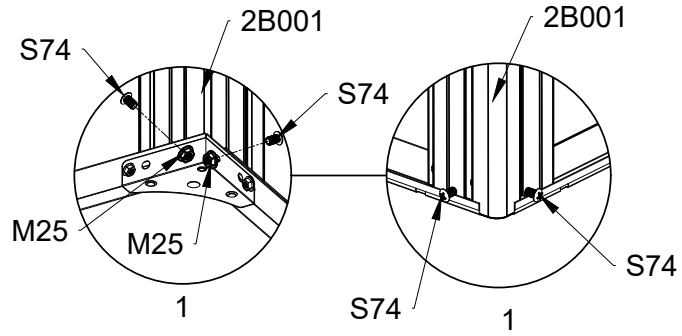

**EXPANSION BOLT INSTALLATION** · INSTALACIÓN DE PERNOS DE EXPANSIÓN · INSTALAÇÃO DE PARAFUSOS DE EXPANSÃO ·  
 INSTALLATION DE BOULONS À EXPANSION · EINBAU VON SPREIZDÜBELN · ΤΟΠΟΘΕΤΗΣΗ ΜΠΟΥΛΟΝΙΩΝ ΔΙΑΣΤΟΛΗΣ · INSTA-  
 LLAZIONE DI TASSELLI AD ESPANSIONE · INSTALACIA DILATAČNYCH SKRÚTIEK · UGRADNJA EKSPANZIJSKIH VIJAKA · MONTÁŽ  
 ROZPĚRNYCH ŠROUBŮ · NAMESTITEV RAZTEZNIH VIJAKOV · EXPANSIONSBULT INSTALLATOR · EXPANSIONSBULT INSTALLATOR

PART	NO	QTY
	2B001	2
	S74	4
	M4X8	
	M25	4
	M4	





PART	NO	QTY
	1H001	1
	2C002	1
	S74	7
	M4X8	
	M25	7
	M4	

**THE END WITH THE HOLE MUST FACE UP FOR THE LATER ASSEMBLY**

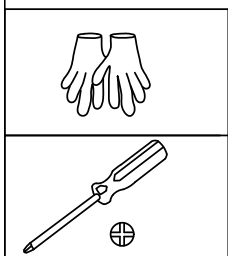
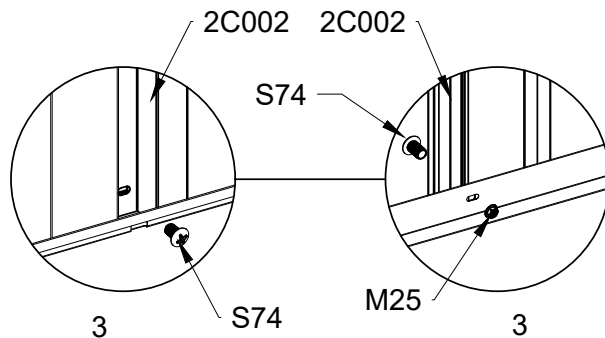
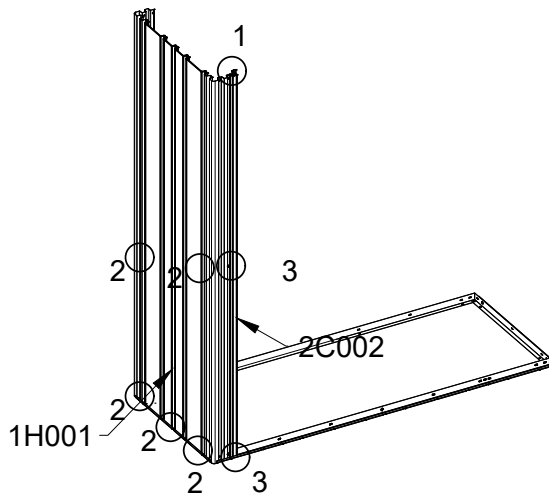
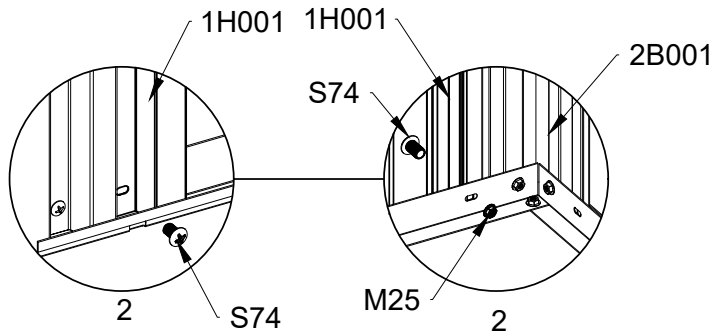
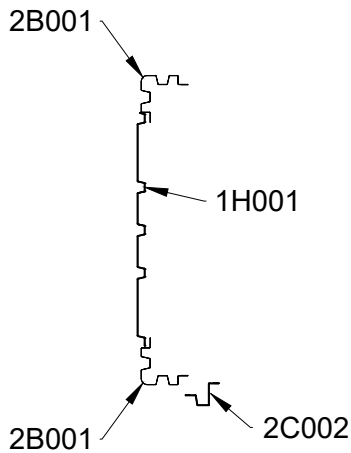
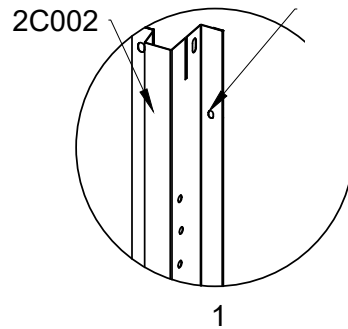
· EL EXTREMO CON EL AGUJERO DEBE MIRAR HACIA ARRIBA PARA EL MONTAJE POSTERIOR · C04B, A EXTREMIDADE COM O ORIFÍCIO DEVE ESTAR VIRADA PARA CIMA PARA A MONTAGEM POSTERIOR · , L'EXTREMITÉ AVEC LE TROU DOIT ÊTRE TOURNÉE VERS LE HAUT POUR UN MONTAGE ULTÉRIEUR · DAS ENDE MIT DEM LOCH MUSS NACH OBEN ZEIGEN ZUR SPÄTEREN MONTAGE · , ΤΟ ΑΚΡΟ ΜΕ ΤΗΝ ΤΡΥΠΑ ΠΡΕΠΕΙ ΝΑ ΒΛΕΠΕΙ ΠΡΟΣ ΤΑ ΠΑΝΩ ΓΙΑ ΜΕΤΑΓΕΝΕΣΤΕΡΗ ΣΥΝΑΡΜΟΛΟΓΗΣΗ · L'ESTREMITÀ CON IL FORO DEVE ESSERE RIVOLTA VERSO L'ALTO PER IL SUCCESSIVO MONTAGGIO · KONEC S OTVOROM MUSÍ SMEROVAT NAHOR NA NÁSLEDNÚ MONTÁŽ · KRAJ S RUPOM MORA BITI OKRENUT PREMA GORE ZA NAKNADNU MONTÁŽU · KONEC S OTVOREM MUSÍ SMĚROVAT NAHORU PRO NÁSLEDNOU MONTÁŽ · KONEC Z LUKNJO MORA BITI OBRNEN NAVZGOR ZA NAKNADNO MONTÁŽO · ÄNDEN MED HÅLET MÅSTE VARA VÄND UPPÅT FÖR SENARE MONTERING · ÄNDEN MED HÅLET MÅSTE VARA VÄND UPPÅT FÖR SENARE MONTERING



PART	NO	QTY
	2B001	2
	S74	4
	M4X8	
	M25	4
	M4	

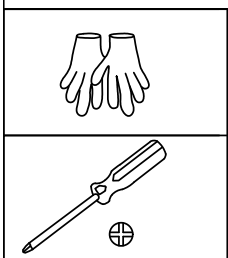
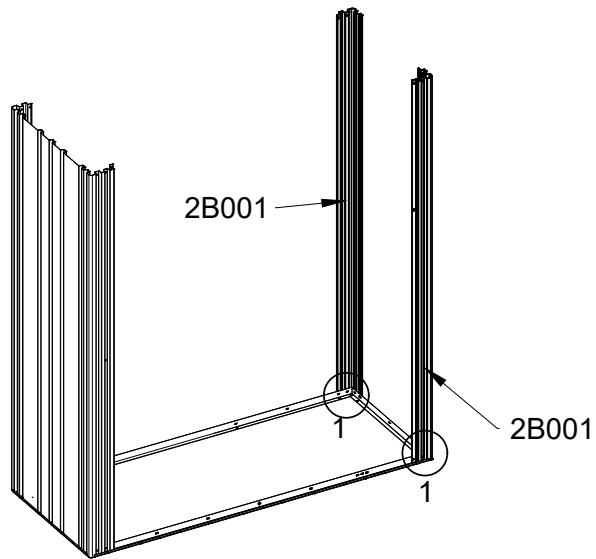
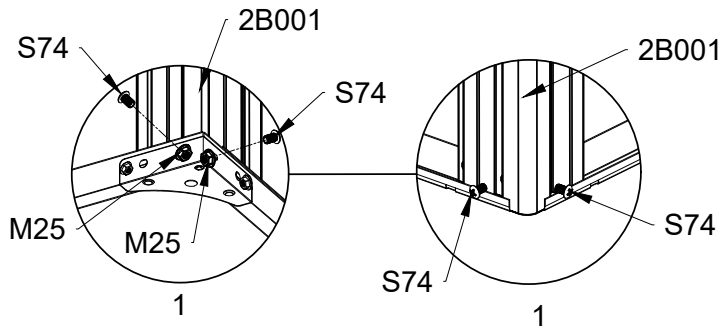

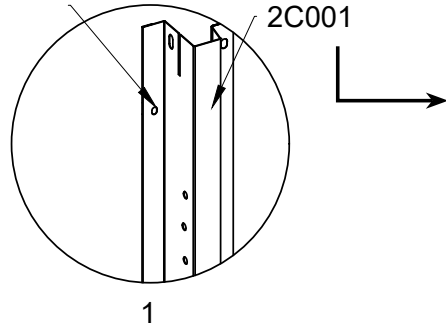

PART	NO	QTY
	1H001	1
	2C001	1
	S74	7
	M25	
	M4	7



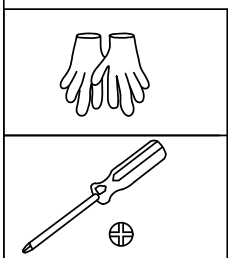
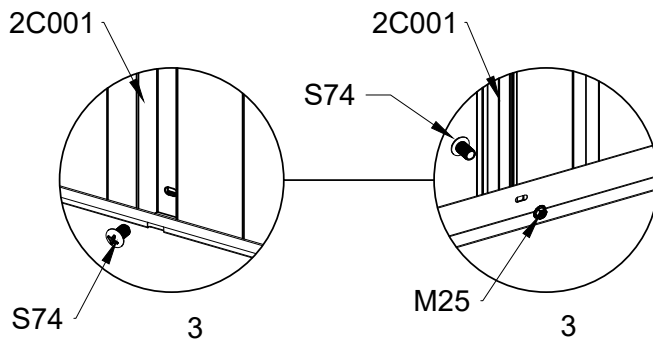
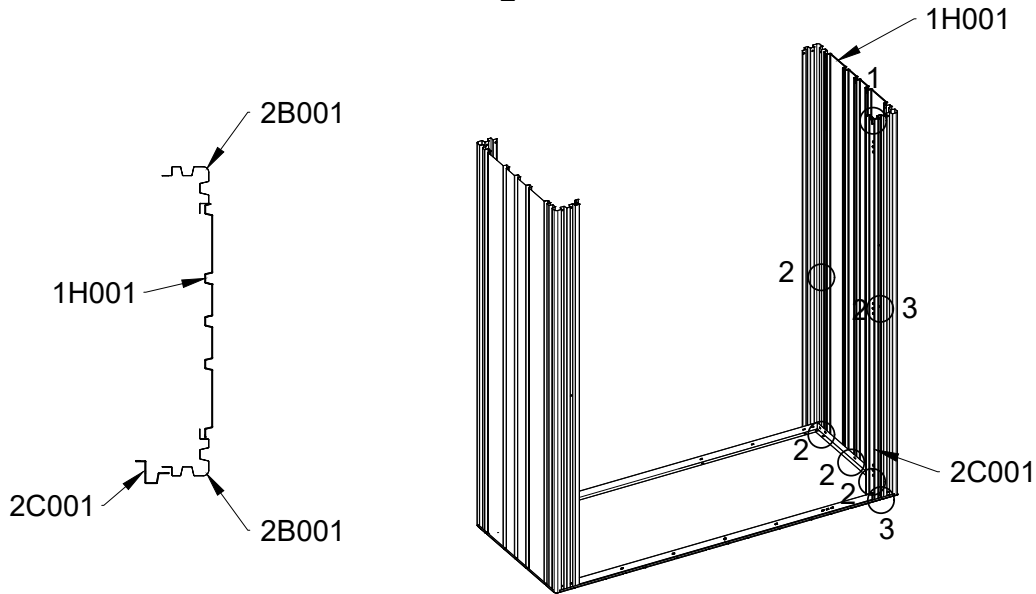
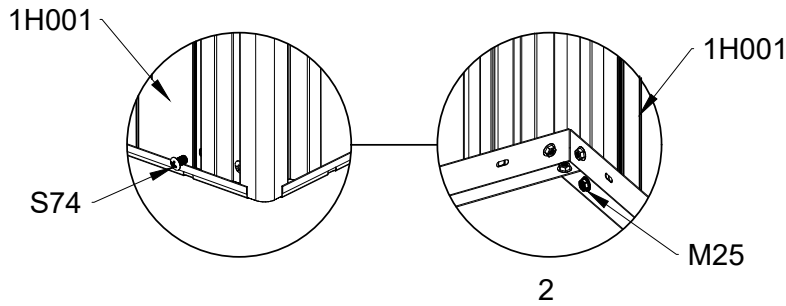

**THE END WITH THE HOLE MUST FACE UP FOR THE LATER ASSEMBLY** - EL EXTREMO CON EL AGUJERO DEBE MIRAR HACIA ARRIBA PARA EL MONTAJE POSTERIOR - CO4B, A EXTREMIDADE COM O ORIFÍCIO DEVE ESTAR VIRADA PARA CIMA PARA A MONTAGEM POSTERIOR - L'EXTREMITÉ AVEC LE TROU DOIT ÊTRE TOURNÉE VERS LE HAUT POUR UN MONTAGE ULTÉRIEUR - DAS ENDE MIT DEM LOCH MUSS NACH OBEN ZEIGEN ZUR SPÄTEREN MONTAGE - TO AKRO ME THIN TRYPIA PREPEI NA BΛEPEI PPOΣ TA ΠANΩ ΓΙΑ ΜΕΤΑΓΕΝΕΣΤΕΡΗ ΣΥΝΑΡΜΟΛΟΓΗΣΗ - L'ESTREMITÀ CON IL FORO DEVE ESSERE RIVOLTA VERSO L'ALTO PER IL SUCCESSIVO MONTAGGIO - KONIEC S OTVOROM MUSI SMEROVAT NAHOR NA NÁSLEDNÚ MONTÁŽ - KRAJ S RUPOM MORA BITI OKRENUJ PREMA GORE ZA NAKNADNU MONTAŽU - KONEC S OTVOREM MUSI SMÉROVAT NAHORU PRO NÁSLEDNOU MONTÁŽ - KONEC Z LUKNJO MORA BITI OBRNEN NAVZGOR ZA NAKNADNO MONTAŽO - ÄNDEN MED HÅLET MÅSTE VARA VÄND UPPÅT FÖR SENARE MONTERING - DELIKLI UÇ DAHA SONRAKI MONTAJ İÇİN YUKARI BAKMALIDIR



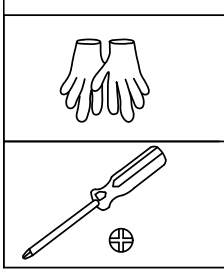
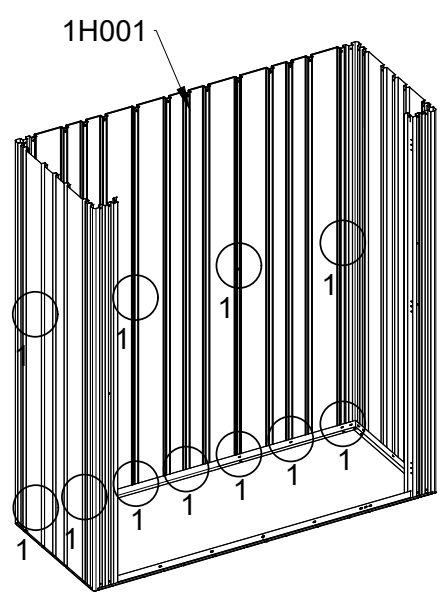
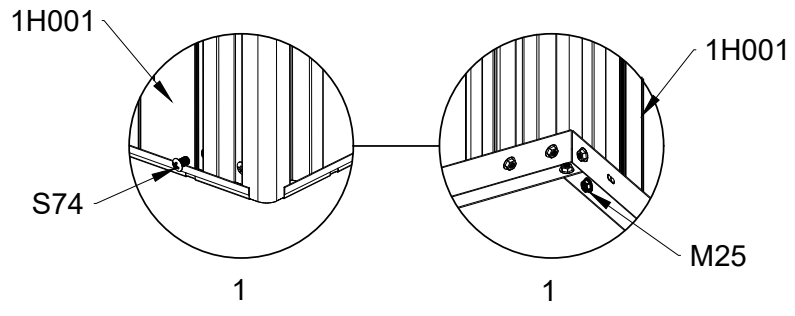

PART	NO	QTY
	1H001	3
	S74	11
	M4X8	
	M25	11
	M4	



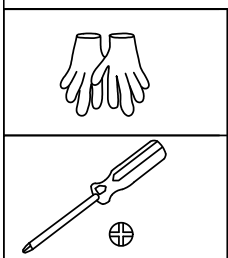
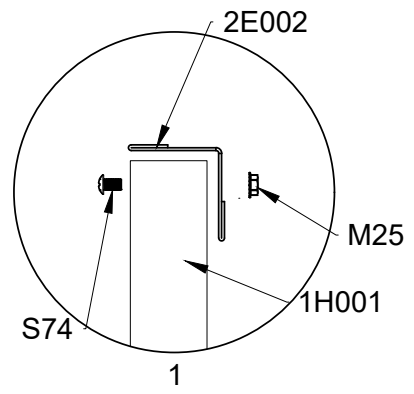
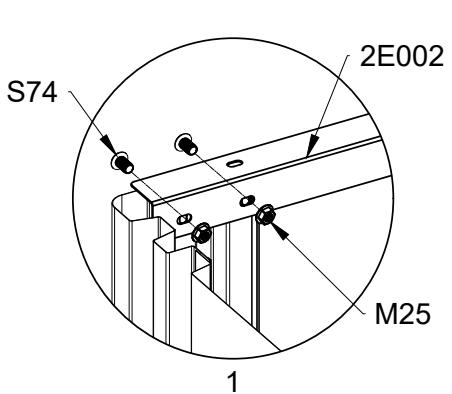
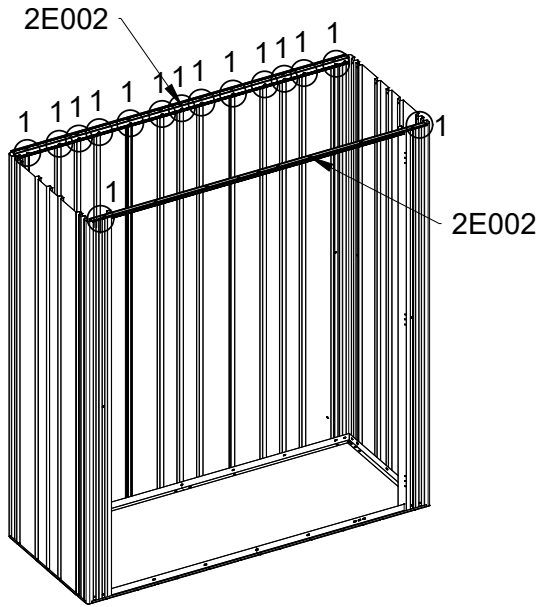



PART	NO	QTY
	2E002	2
	S74	20
	M4X8	
	M25	20
	M4	



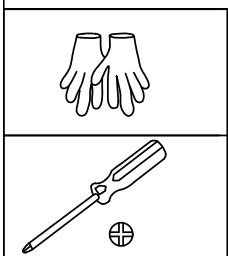
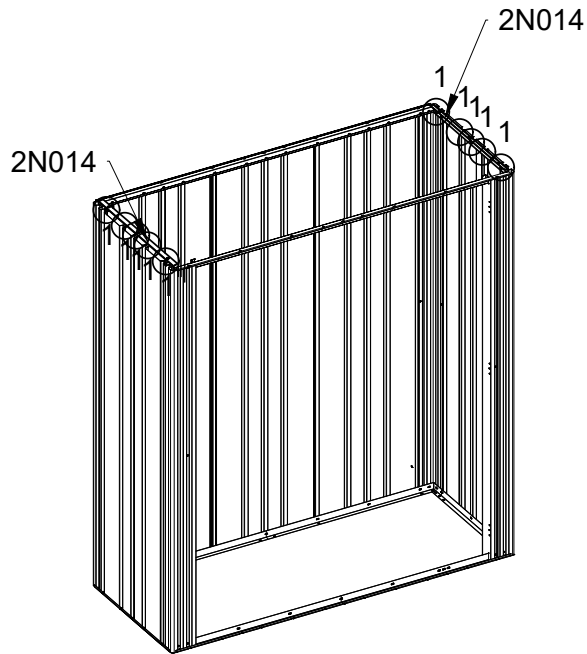
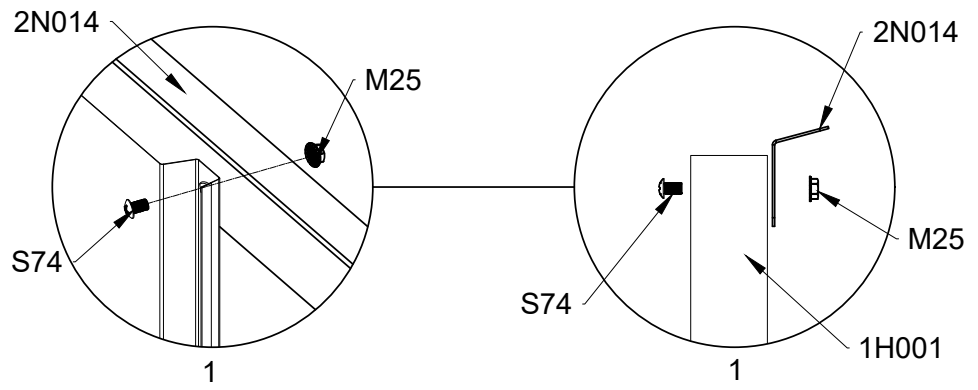





PART	NO	QTY
	2N014	2
	S74	12
	M4X8	
	M25	12
	M4	

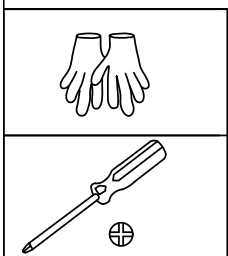
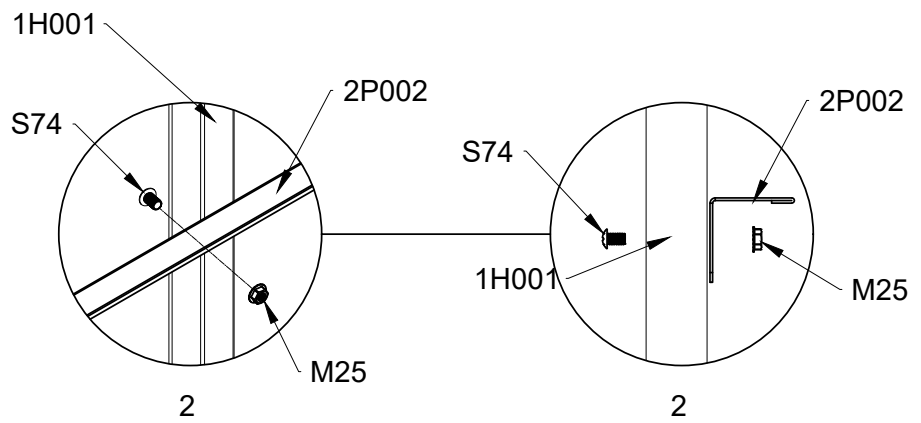
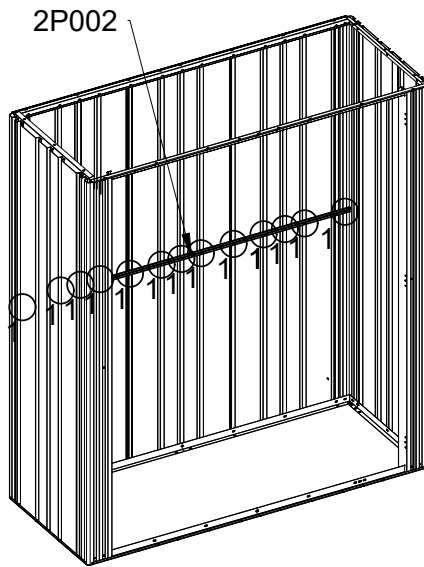





PART	NO	QTY
	2P002	1
	S74 M4X8	14
	M25 M4	14

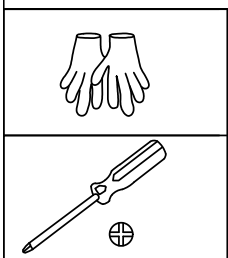
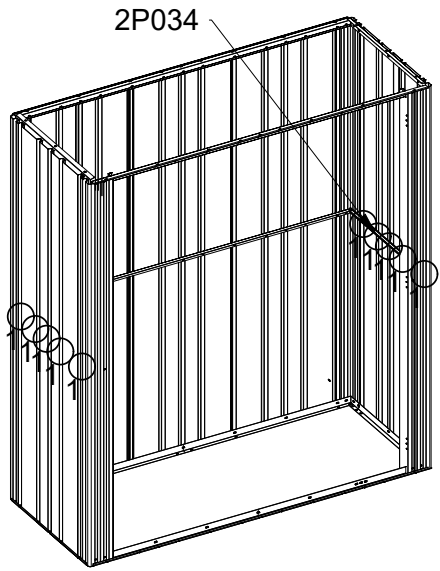
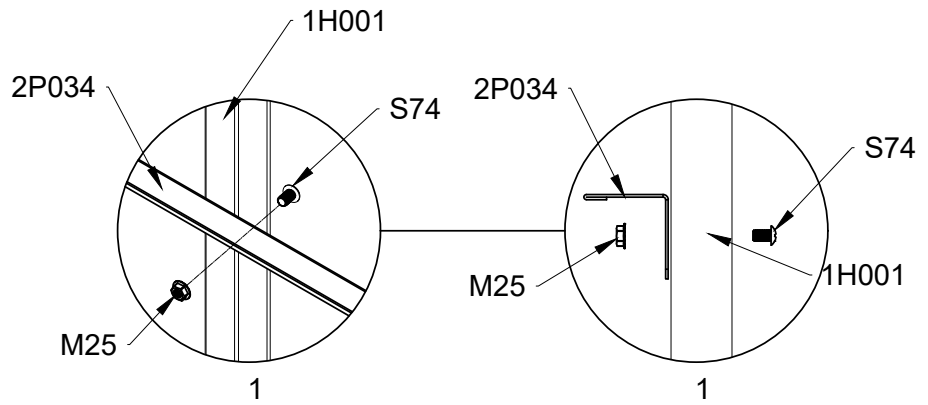



PART	NO	QTY
	2P034	2
	S74 M4X8	10
	M25 M4	10



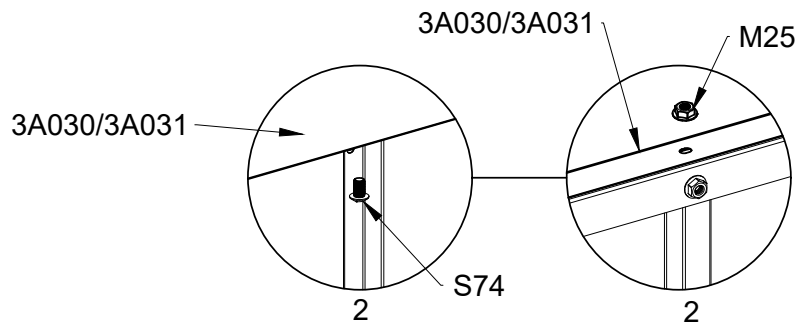
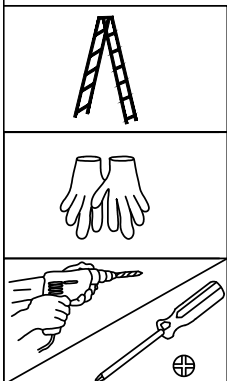
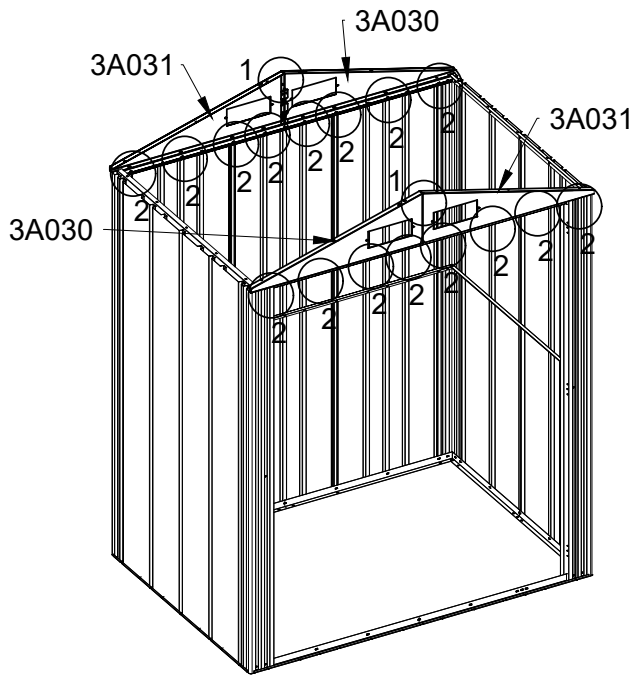
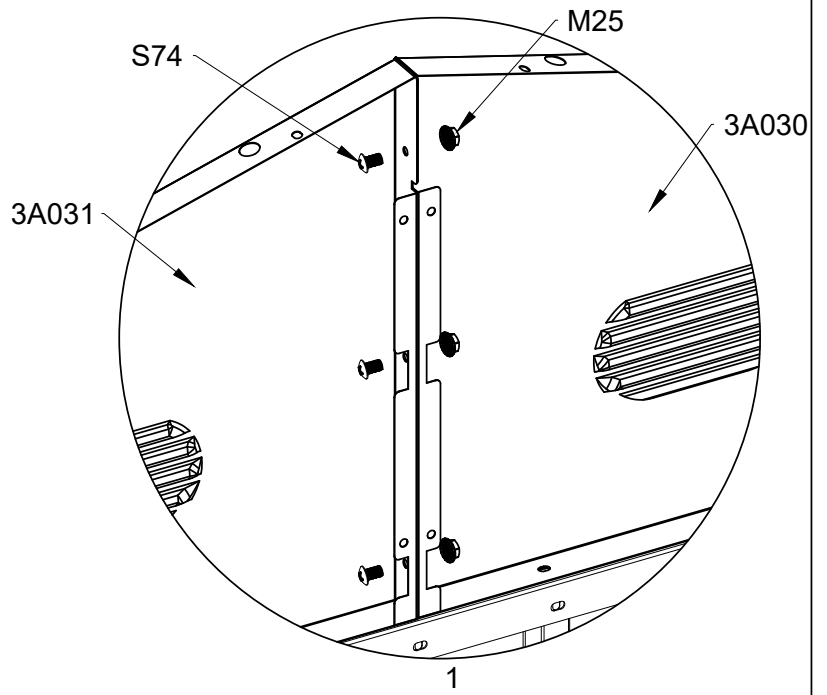

PART	NO	QTY
	3A030	2
	3A031	2
	S74 M4X8	22
	M25 M4	22



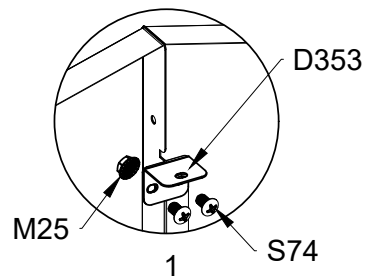
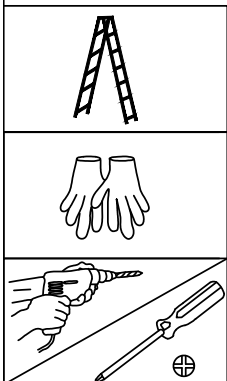
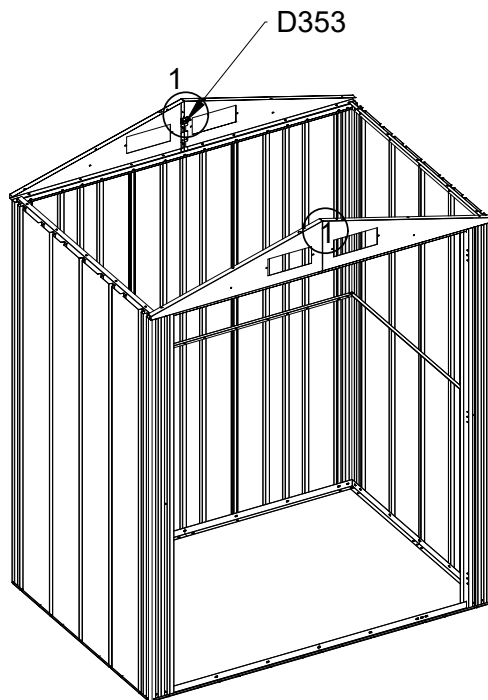



PART	NO	QTY
	D353	2
	S74	4
	M4X8	
	M25	4
	M4	

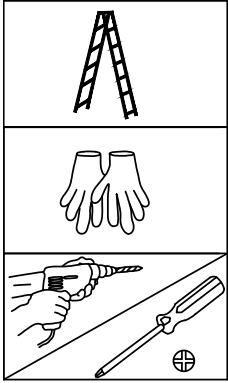
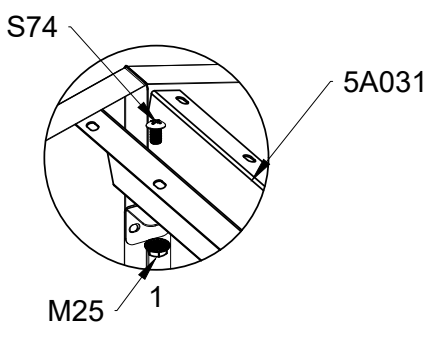
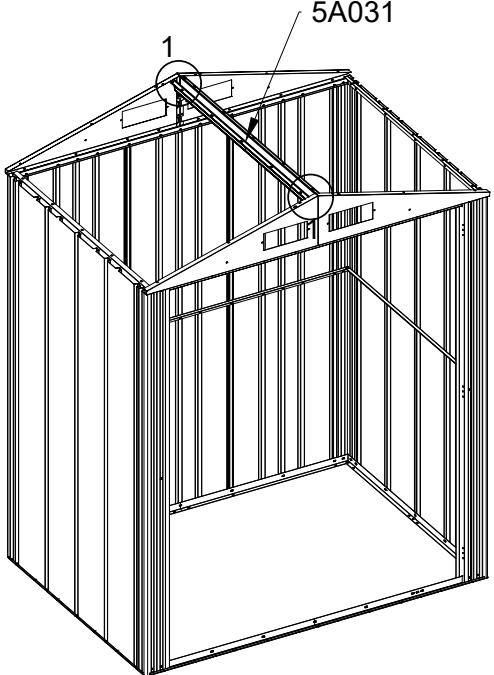

PART	NO	QTY
	5A031	1
	S74 M4X8	2
	M25 M4	2







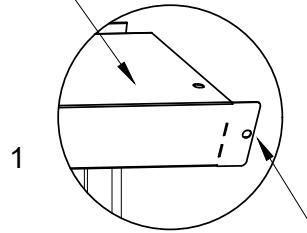

PART	NO	QTY
	3G001	2
	3G002	2
	S74	12
	M4X8	
	M25	12
	M4	
	H127	12

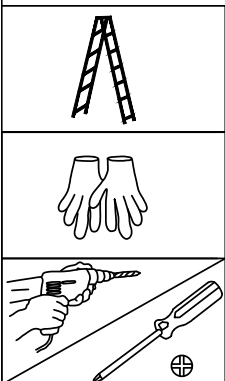
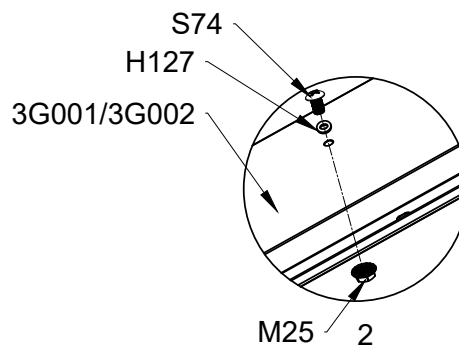
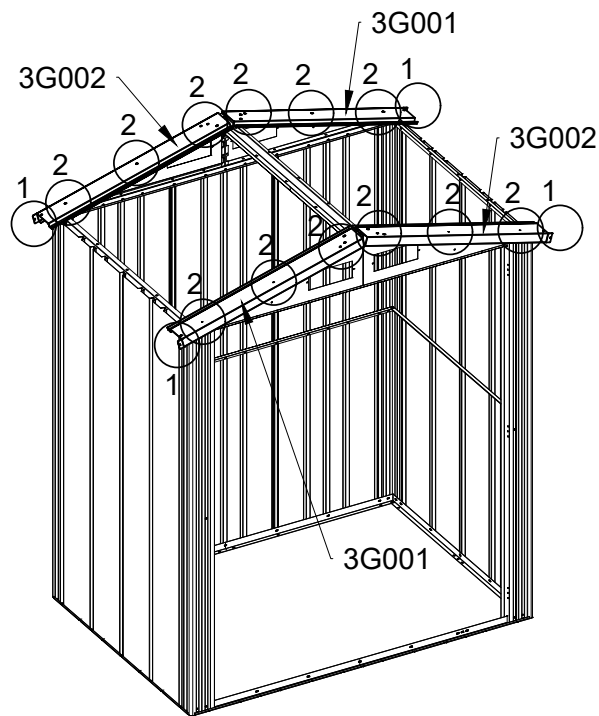
3G001/3G002







**THE EXTENDED SIDE FACES OUTWARD** ·  
 LA CARA EXTENDIDA MIRA HACIA AFUERA ·  
 O LADO ESTENDIDO ESTÁ VOLTADO PARA  
 FORA · LE CÔTÉ ALLONGÉ EST TOURNÉ VERS  
 L'EXTÉRIEUR · DIE VERLÄNGERTE SEITE IST  
 NACH AUSSEN GERICHTET · Η ΕΚΤΕΤΑΜΕΝΗ  
 ΠΛΕΥΡΑ ΒΛΕΠΕΙ ΠΡΟΣ ΤΑ ΕΞΩ · IL LATO  
 ALLUNGATO È RIVOLTO VERSO L'ESTERNO ·  
 PREDLŽENÁ STRANA JE OTOČENÁ SMEROM  
 VON · ISTAKNUTA STRANA OKRENUTA  
 JE PREMA VAN · PRODLOUŽENÁ STRANA  
 SMĚRUJE VEN · PODALJŠANA STRANICA JE  
 OBRNJENA NAVZVEN · FÖRLÄNGD SIDA VÄND  
 UTÅT · DIŞA BAKAN UZATILMIŞ TARAF

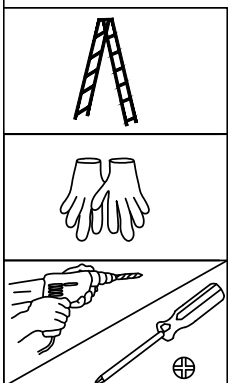
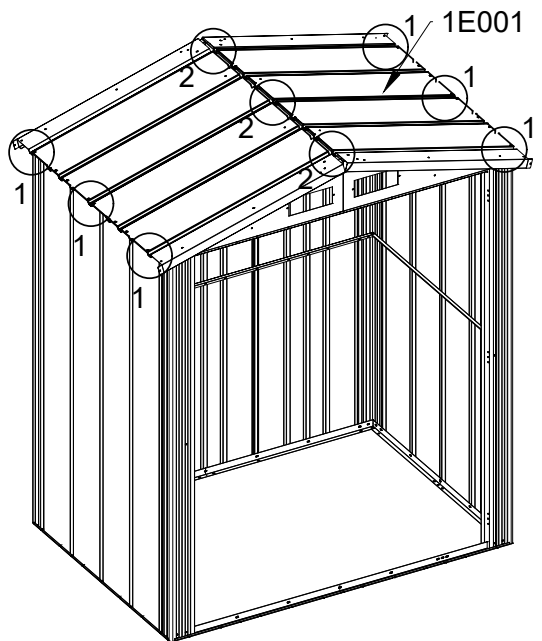
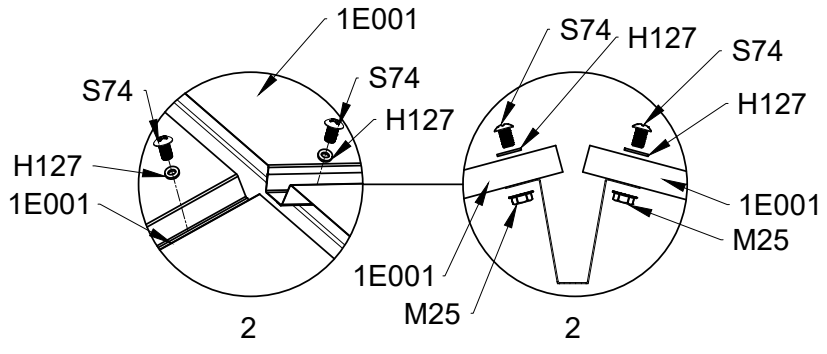
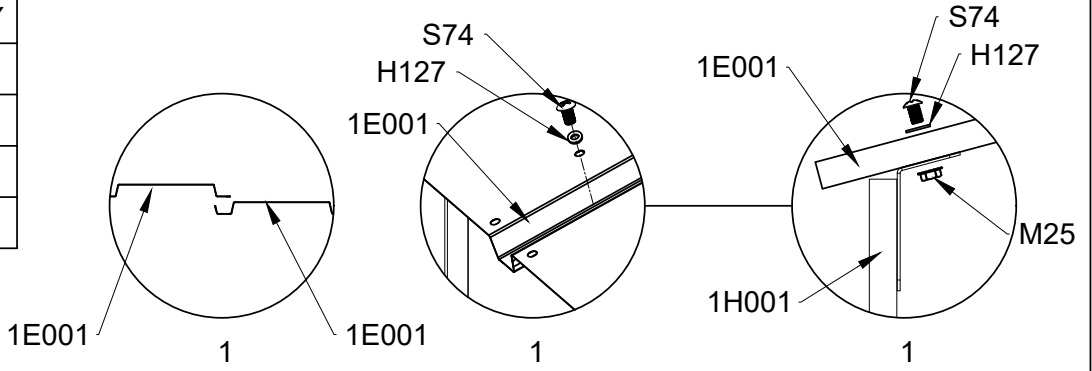





PART	NO	QTY
	1E001	2
	S74	12
	M4X8	
	M25	12
	M4	
	H127	12



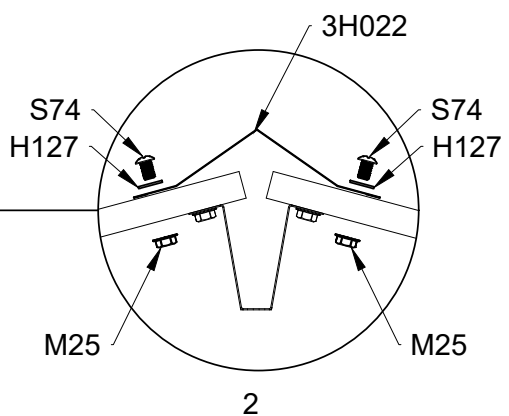
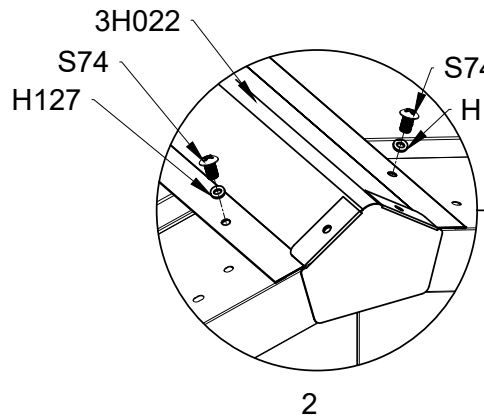
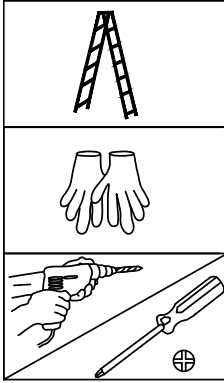
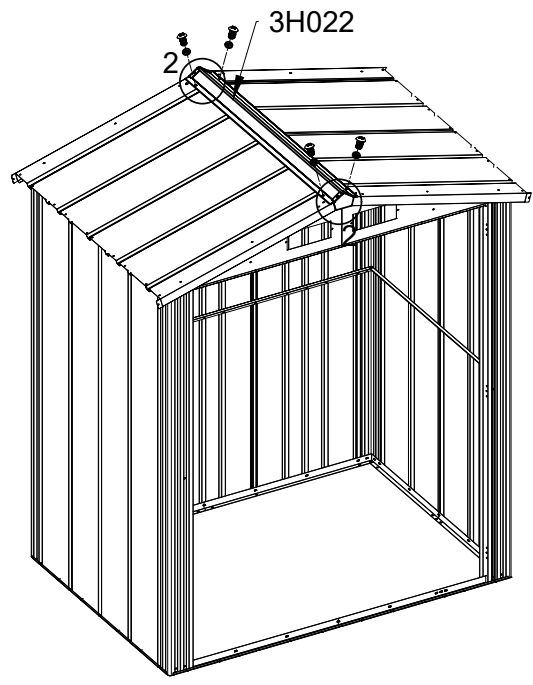
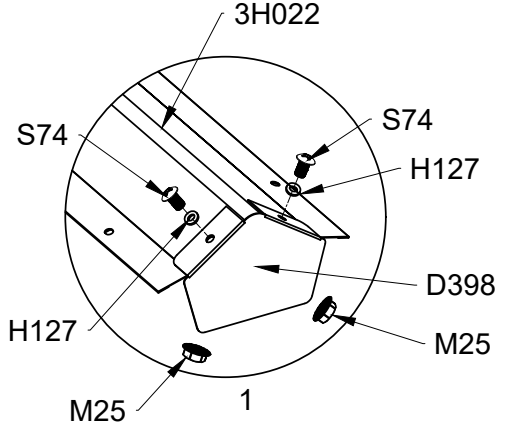
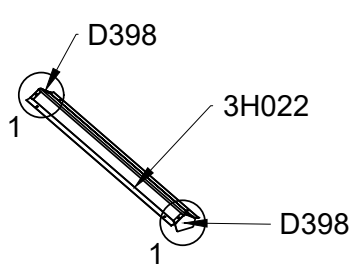

PART	NO	QTY
	3H022	1
	D398	2
	S74	8
	M4X8	
	M25	8
	M4	
	H127	8



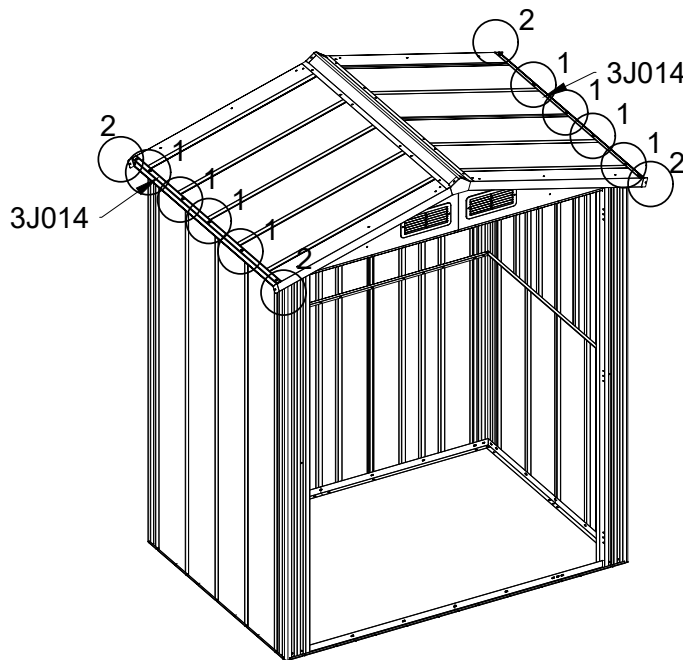
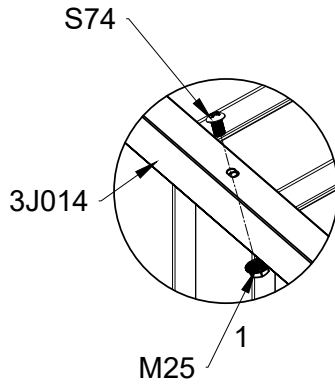

PART	NO	QTY
	3J014	2
	S74 M4X8	12
	M25 M4	12

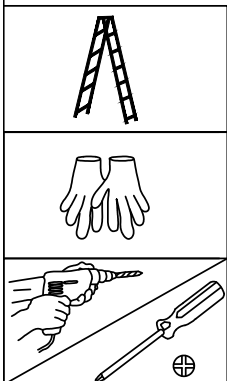
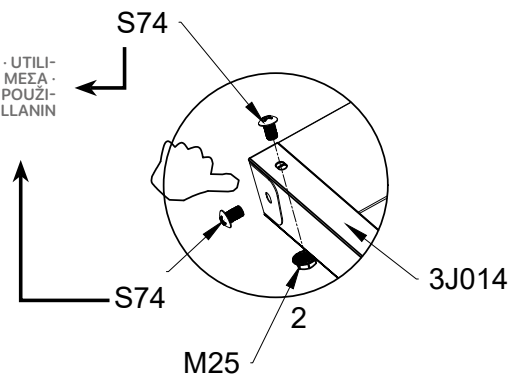

**USE M25 INSIDE** · UTILIZAR M25 EN EL INTERIOR · UTILIZAR A M25 NO INTERIOR · UTILISER M25 À L'INTÉRIEUR · VERWENDEN SIE INNEN M25 · ΧΡΗΣΙΜΟΠΟΙΗΣΤΕ ΤΟ Μ25 ΜΕΣΑ · USA M25 ALL'INTERNO · VNÚTRI POUŽÍTE M25 · KORISTITE M25 UNUTRA · UVNITR POUŽÍJTE M25 · UPORABITE M25 ZNOTRAJ · ANVÄND M25 INUTI · M25'İ İÇERİDE KULLANIN



**FLIP THE FOLDED EDGES OF 3G001/3G002 OVER TO COVER 3J014** · VOLTEE LOS BORDES DOBLADOS DE 3G001/3G002 PARA CUBRIR 3J014 · VIRAR OS BORDOS DOBRADOS DE 3G001/3G002 PARA COBRIR 3J014 · RETOURNER LES BORDS PLIÉS DE 3G001/3G002 POUR COUVRIR 3J014 · KLAPPEN SIE DIE GEFALTETEN KANTEN VON 3G001/3G002 UM, UM 3J014 ZU BEDECKEN · ΑΝΑΠΟΔΟΓΥΡΙΣΤΕ ΤΙΣ ΔΙΠΛΩΜΕΝΕΣ ΑΚΡΕΣ ΤΩΝ 3G001/3G002 ΓΙΑ ΝΑ ΚΑΛΥΨΕΤΕ ΤΟ 3J014 · ΠΡΕΚΛΟΠΤΕ ΖΛΟΖΕΝΕ ΟΚΡΑЈЕ 3G001/3G002 ΤΑΚ, ΑΒΥ ΖΑΚΡΥΨΑΛΙ 3J014 · CĀPOVOLΓERE I BORDI RIPIEGATI DI 3G001/3G002 PER COPRIRE 3J014 · PREKRENITE PRESAVIJENE RUBOVE 3G001/3G002 DA POKRIJETE 3J014 · PŘELOŽTE PŘELOŽENÉ OKRAJE 3G001/3G002 TAK, ABY ZAKRYVALY 3J014 · PREPOGNJENE ROBOVE 3G001/3G002 OBRNITE, DA PREKRIJETE 3J014 · VÄND DE VIKTA KANTERNA PÅ 3G001/3G002 SÅ ATT DE TÄCKER 3J014 · 3G001/3G002'NIN KATLANMIŞ KENARLARINI 3J014'Ü KAPATAÇAK ŞEKİLDE TERS ÇEVİRİN

PART	NO	QTY
	D354	6
	S75	18
	M4X10	
	M25	18
	M4	

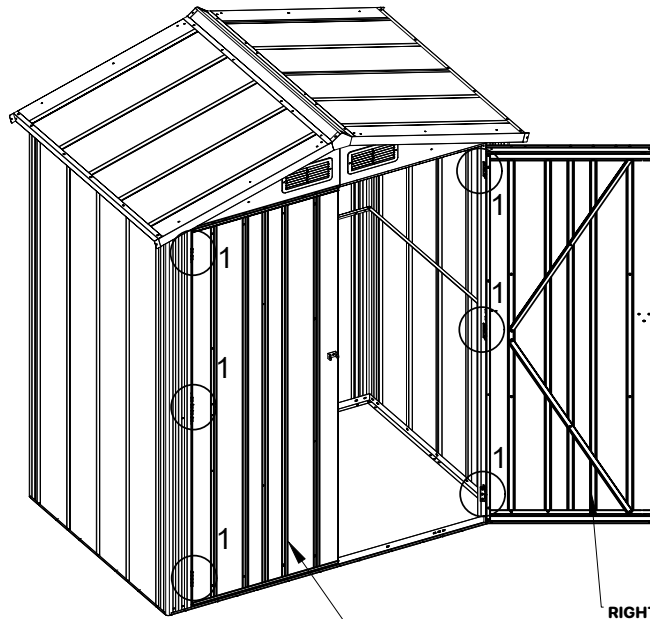

**LEFT DOOR** · PUERTA IZQUIERDA · PORTA ESQUERDA · PORTE GAUCHE · LINKE TÜR · ΑΡΙΣΤΕΡΗ ΠΟΡΤΑ · PORTA SINISTRA · LAVÉ DVERÉ · LIJEVA VRATA · LEVÉ DVERÉ · LEVA VRATA · VÄNSTER DÖRR · VÄNSTER DÖRR

**RIGHT DOOR** · PUERTA DERECHA · PORTA DIREITA · PORTE DROITE · RECHTE TÜR · ΔΕΞΙΑ ΠΟΡΤΑ · PORTA DESTRA · PRAVÉ DVERÉ · DESNA VRATA · PRAVÉ DVERÉ · DESNA VRATA · HÖGER DÖRR · SAĞ KAPI

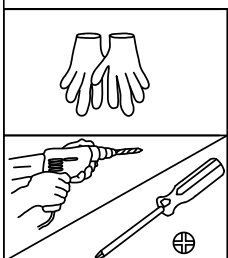
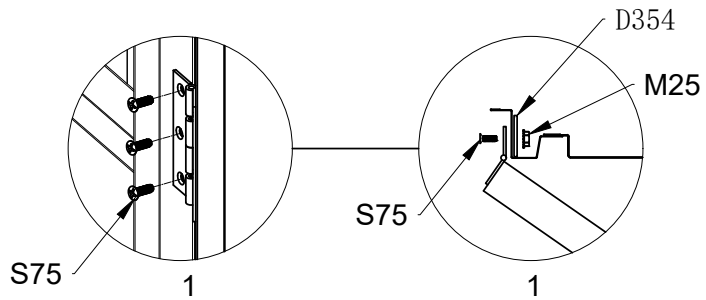

PART	NO	QTY
	A112	1

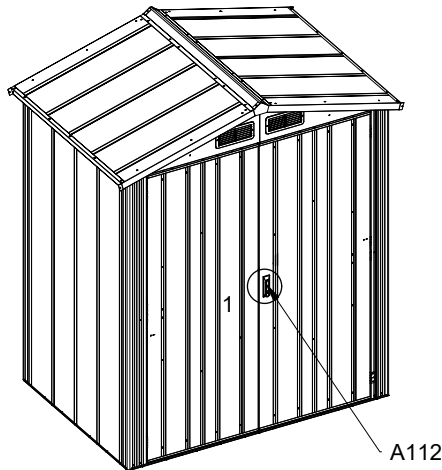

**LOOSEN THE SCREW, SEPARATE THE FIXING PLATE AND SCREW OF A112 FROM THE A112** · AFLOJE EL TORNILLO, SEPARA LA PLACA DE FIJACIÓN Y EL TORNILLO DEL A112 DEL A112 · DESAPERTAR O PARAFUSO, SEPARAR A PLACA DE FIXAÇÃO E O PARAFUSO DO A112 DO A112 · DESSERRER LA VIS, SÉPARER LA PLAQUE DE FIXATION ET LA VIS DE L'A112 DE L'A112 · LÖSEN SIE DIE SCHRAUBE, TRENNEN SIE DIE BEFESTIGUNGSPLATTE UND DIE SCHRAUBE DER A112 VON DER A112 · ΧΑΛΑΡΩΣΤΕ ΤΗ ΒΙΔΑ, ΔΙΑΧΩΡΙΣΤΕ ΤΗΝ ΠΛΑΚΑ ΣΤΕΡΕΩΣΗΣ ΚΑΙ ΤΗ ΒΙΔΑ ΤΟΥ A112 ΑΠΟ ΤΟ A112 · ALLENTARE LA VITE, SEPARARE LA PIASTRA DI FISSAGGIO E LA VITE DELL'A112 DALL'A112 · UVOLNITE SKRUTKU, ODDELTE UPEVNŔOVACIU DOSKU A SKRUTKU A112 OD A112 · OTPUSTITE VIJAK, ODVOJITE PRIČVRSNU PLOČU I VIJAK A112 OD A112 · POVOLTE ŠROUB, ODDELTE UPEVNŔOVACIU DESKU A ŠROUB A112 OD A112 · ODVIJTE VIJAK, LOČITE PRITRDILNO PLOŠČO IN VIJAK NAPRAVE A112 OD NAPRAVE A112 · LOSSA SKRUVEN, TA BORT FÄSTPLATTAN OCH SKRUVEN PÅ A112 FRÅN A112 · VIDAYI GEVŞETİN, A112'NİN SABİTLEMELERİNİ VE VIDASINI A112'DEN AYIRIN

**PLACE A112 INTO THE CORRESPONDING POSITION ON THE RIGHT DOOR (AS SHOWN IN THE FIGURE)** · COLOQUE A112 EN LA POSICIÓN CORRESPONDIENTE DE LA PUERTA DERECHA (COMO SE MUESTRA EN LA FIGURA) · COLOQUE A112 EN LA POSICIÓN CORRESPONDIENTE DE LA PUERTA DERECHA (COMO SE MUESTRA EN LA FIGURA) · PLACER A112 DANS LA POSITION CORRESPONDANTE SUR LA PORTE DE DROITE (COMME INDIQUÉ SUR LA FIGURE) · SETZEN SIE A112 IN DIE ENTSPRECHENDE POSITION AN DER RECHTEN TÜR EIN (WIE IN DER ABBILDUNG GEZEIGT) · ΤΟΠΟΘΕΤΗΣΤΕ ΤΟ A112 ΣΤΗΝ ΑΝΤΙΣΤΟΙΧΗ ΘΕΣΗ ΣΤΗ ΔΕΞΙΑ ΠΟΡΤΑ (ΟΠΩΣ ΦΑΙΝΕΤΑΙ ΣΤΟ ΣΧΗΜΑ) · POSIZIONARE A112 NELLA POSIZIONE CORRISPONDENTE SULLA PORTA DESTRA (COME MOSTRATO NELLA FIGURA) · UMIESTNITE A112 DO PRÍSLUŠNEJ POZÍCIE NA PRÁVYCH DVERÁCH (AKO JE ZNÁZORNENÉ NA OBRÁZKU) · POSTAVITE A112 NA ODGOVÁRAJUĆU POZICIJU NA DESNIM VRATIMA (KAO ŠTO JE PRIKAZANO NA SLICI) · UMÍŠTĚTE A112 DO ODPOVÍDÁJÍCÍ POZICE NA PRÁVYCH DVERÍCH (JAK JE ZNÁZORNĚNO NA OBRÁZKU) · POSTAVITE A112 NA USTREZNO MESTO NA DESNIH VRATIH (KOT JE PRIKAZANO NA SLIKI) · PLACERA A112 I MOTSVARANDE POSITION PÅ DEN HÖGRA DÖRREN (SOM VISAS I FIGUREN) · A112'YI SAĞ KAPIDAKI İLGİLİ KONUMA YERLEŞTİRİN (ŞEKİLDE GÖSTERİLDİĞİ GİBİ)

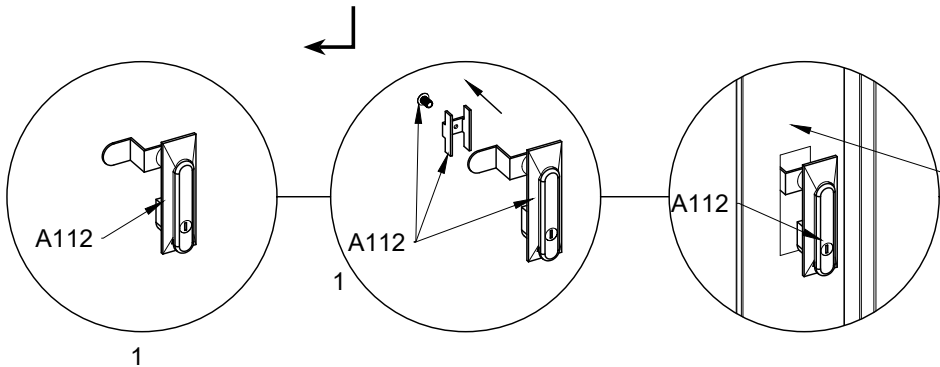

**RIGHT DOOR** · PUERTA DERECHA · PORTA DIREITA · PORTE DROITE · RECHTE TÜR · ΔΕΞΙΑ ΠΟΡΤΑ · PORTA DESTRA · PRÁVĚ DVERĚ · DESNA VRATA · PRÁVĚ DVERĚ · DESNA VRATA · HÖGER DÖRR · SAĞ KAPI

**REINSTALL THE FIXING PLATE AND SCREWS, SECURELY FIXING A112** · VUELVA A INSTALAR LA PLACA DE FIJACIÓN Y LOS TORNILLOS, FIJANDO FIRMEMENTE A112 · VUELVA A INSTALAR LA PLACA DE FIJACIÓN Y LOS TORNILLOS, FIJANDO FIRMEMENTE A112 · REMETTRE EN PLACE LA PLAQUE DE FIXATION ET LES VIS, EN FIXANT SOLIDEMENT A112 · BRINGEN SIE DIE BEFESTIGUNGSPLATTE UND DIE SCHRAUBEN WIEDER AN UND BEFESTIGEN SIE A112 · ΕΠΑΝΑΤΟΠΟΘΕΤΗΣΤΕ ΤΗΝ ΠΛΑΚΑ ΣΤΕΡΕΩΣΗΣ ΚΑΙ ΤΙΣ ΒΙΔΕΣ, ΣΤΕΡΕΩΝΟΝΤΑΣ ΜΕ ΑΣΦΑΛΕΙΑ A112 · REINSTALLARE LA PIASTRA DI FISSAGGIO E LE VITI, FISSANDO SALDAMENTE A112 · ZNOVU NAMONTUJTE UPEVNŔOVACIU DOSKU A SKRUTKY, KTORÉ BEZPEČNĚ UPEVNIA A112 · PONOVNOSTAVITE PRIČVRSNU PLOČU I VIJKE, ČVRSTO PRIČVRSTIVŠI A112 · ZNOVU NAMONTUJTE UPEVNŔOVACIU DESKU A ŠROUBY A PEVNĚ JE PRIPEVNĚTE A112 · PONOVNOSTAVITE PRITRDILNO PLOŠČO IN VIJAKE TER TRDNO PRITRDNITE A112 · SÄTT TILLBÄKA FÄSTPLATTAN OCH SKRUVARNA, SÅ ATT A112 SITTER ORDENTLIGT FAST · SABİTLEMELERİNİ VE VIDALARI YENİDEN TAKIN, A112'YI GÜVENLİ BİR ŞEKİLDE SABİTLEYİN

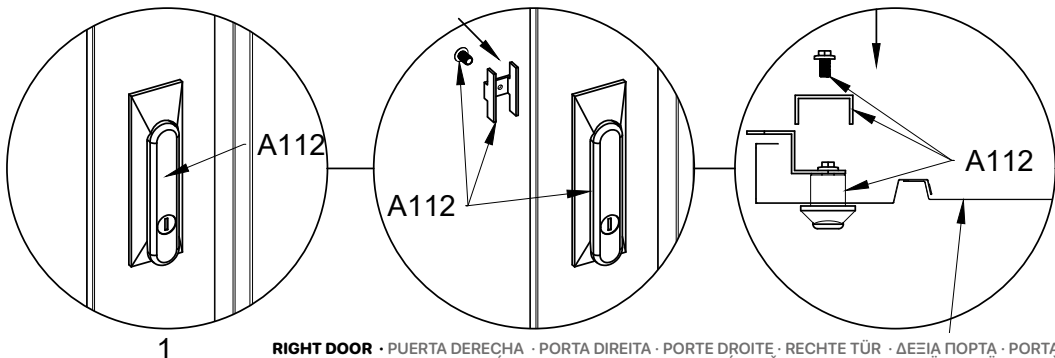
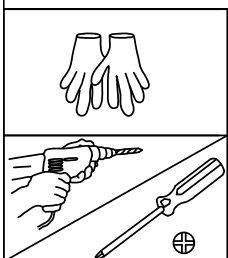

**RIGHT DOOR** · PUERTA DERECHA · PORTA DIREITA · PORTE DROITE · RECHTE TÜR · ΔΕΞΙΑ ΠΟΡΤΑ · PORTA DESTRA · PRÁVĚ DVERĚ · DESNA VRATA · PRÁVĚ DVERĚ · DESNA VRATA · HÖGER DÖRR · SAĞ KAPI

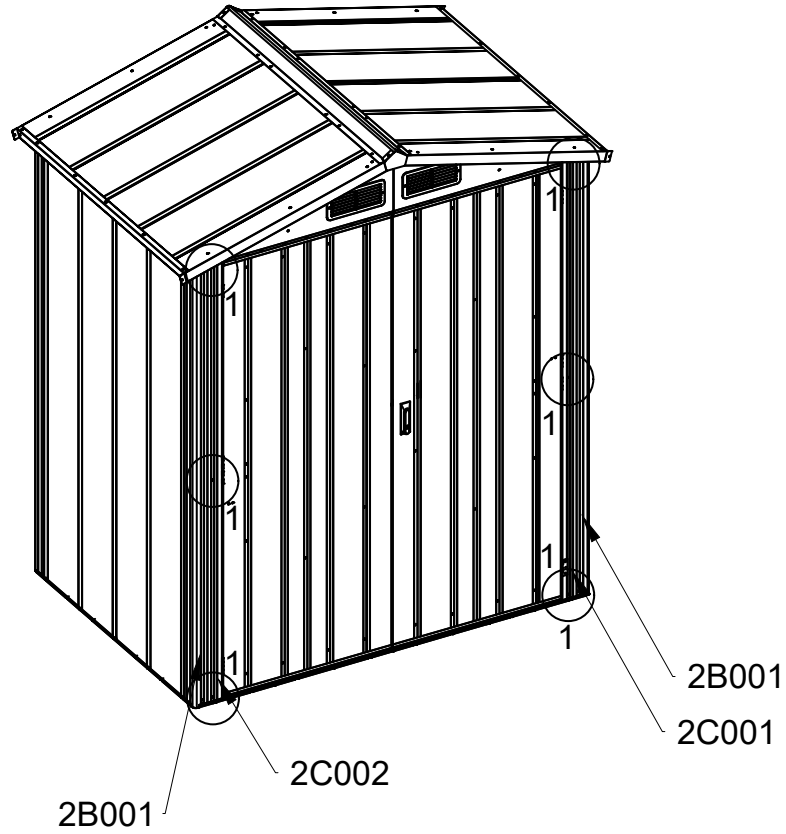

**THE PARALLELISM OF THE DOOR CAN BE ADJUSTED BY MOVING 2C001/2C002 LEFT** · EL PARALELISMO DE LA PUERTA PUEDE AJUSTARSE MOVIENDO 2C001/2C002 A IZQUIERDA Y DERECHA UTILIZANDO ESTOS SEIS PARAFUSOS · O PARALELISMO DA PORTA PODE SER AJUSTADO DESLOCANDO 2C001/2C002 PARA A ESQUERDA E PARA A DIREITA, UTILIZANDO ESTES SEIS PARAFUSOS · LE PARALLÉLISME DE LA PORTE PEUT ÊTRE RÉGLÉ EN DÉPLAÇANT 2C001/2C002 VERS LA GAUCHE ET VERS LA DROITE EN UTILISANT CES SIX VIS · DIE PARALLELITÄT DER TÜR KANN DURCH VERSCHIEBEN VON 2C001/2C002 NACH LINKS UND RECHTS MIT DIESEN SECHS SCHRAUBEN EINGESTELLT WERDEN · Ο ΠΑΡΑΛΛΗΛΙΣΜΟΣ ΤΗΣ ΠΟΡΤΑΣ ΜΠΟΡΕΙ ΝΑ ΡΥΘΜΙΣΤΕΙ ΜΕΤΑΚΙΝΩΝΤΑΣ ΤΙΣ 2C001/2C002 ΑΡΙΣΤΕΡΑ ΚΑΙ ΔΕΞΙΑ ΧΡΗΣΙΜΟΠΟΙΩΝΤΑΣ ΑΥΤΕΣ ΤΙΣ ΕΞΙ ΒΙΔΕΣ · Ο ΠΑΡΑΛΛΗΛΙΣΜΟΣ ΤΗΣ ΠΟΡΤΑΣ ΜΠΟΡΕΙ ΝΑ ΡΥΘΜΙΣΤΕΙ ΜΕΤΑΚΙΝΩΝΤΑΣ ΤΙΣ 2C001/2C002 ΑΡΙΣΤΕΡΑ ΚΑΙ ΔΕΞΙΑ ΧΡΗΣΙΜΟΠΟΙΩΝΤΑΣ ΑΥΤΕΣ ΤΙΣ ΕΞΙ ΒΙΔΕΣ · ROVNOBEŽNOST DVEŘÍ MOŽNO NASTAVIT POSUNUTÍM 2C001/2C002 DOĽAVA A DOPRAVA POMOCOU TYCHTO ŠIESTICH SKRUTIEK · PARALELNOST VRATA MOŽE SE PODESITI POMICANJEM 2C001/2C002 LIJEVO I DESNO POMOCU OVÍH ŠEST VIJAKA · ROVNOBEŽNOST DVEŘÍ LZE NASTAVIT POSUNUTÍM 2C001/2C002 DOLEVA A DOPRAVA POMOCÍ TĚCHTO ŠESTI ŠROUBŮ · ROVNOBEŽNOST DVEŘÍ LZE NASTAVIT POSUNUTÍM 2C001/2C002 DOLEVA A DOPRAVA POMOCÍ TĚCHTO ŠESTI ŠROUBŮ · DÖRRENS PARALLELITET KAN JUSTERAS GENOM ATT FLYTTA 2C001/2C002 ÅT VÄNSTER · KAPININ PARALLELIĞI 2C001/2C002 SOLA HAREKET ETTIRILEREK AYARLANABİLİR

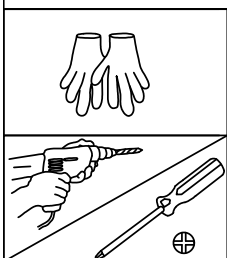

**DOOR** · PUERTA · PORTA ·  
PORTE · TÜR · ΘΥΡΑ · DVEŘE ·  
VRATA · DVEŘE · VRATA ·  
DÖRR · KAPI

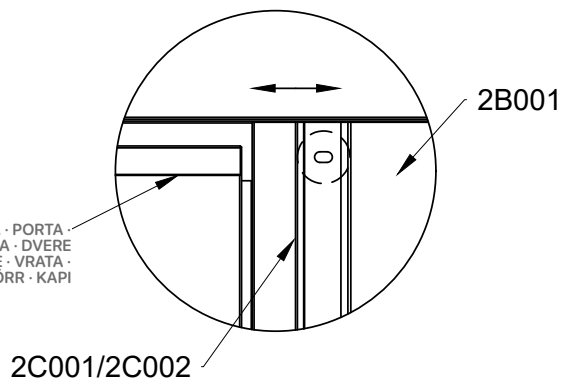

 **Hoggar**<sup>®</sup>

**Pioneer** SERIES  
QUALITY GARDEN STORAGE

OKORU GLOBAL S.L.U. // Polígono Industrial de Barros Nave 29, 39408 Barros, Cantabria - España  
(+34) 942 842 170 · info@okoru.es // MADE IN P.R.C. // SKU: G01ME0087

