

GARDEN SHED

Caseta de jardín · Arrumação exterior · Abri de jardim
Gerätehaus · Σπιτάκι · Záhradné domčeky · Vrtne kućice
Zahradní domek · Vrtne hišice

6,2m²



USER'S MANUAL · MANUAL DE INSTRUCCIONES · MANUAL DE INSTRUÇÕES
MANUEL D'INSTRUCTIONS · GEBRAUCHSANWEISUNG · ΕΓΧΕΙΡΙΔΙΟ ΧΡΗΣΤΗ
MANUALE DI ISTRUZIONI · NÁVOD NA POUŽITIE · PRIRUČNIK
NÁVOD K POUŽITÍ · NAVODILA ZA UPORABO



INDEX

Índice - Inhaltsverzeichnis - Indice - Kazalo

EN		User's manual	04
ES		Manual de instrucciones	05
PT		Manual de instruções	06
FR		Manuel d'instructions	07
DE		Gebrauchsanweisung	08
EL		Εγχειρίδιο χρήστη	09
IT		Manuale di istruzioni	10
SK		Návod na použitie	11
HR		Priručnik	12
CS		Návod k použití	13
SL		Navodila za uporabo	14

Assembly - Montaje - Montagem
Montage - Συναρμολόγηση
Montaggio - Montáž - Montaža....15

USER'S MANUAL

Before we begin...

We want to thank you for choosing one of our products. The assembly process may require a little patience and time, but don't worry, we are here to encourage you! 😊

Once you are finished think of the satisfaction and pride you will feel when you see your finished work and know that you have done it yourself. Also, by assembling it you are making a contribution to the environment. How? As it is not delivered fully assembled, less packaging is used, which means less waste and less waste. In this way each product takes up less space and therefore you make the most of the means of transport, thus reducing CO₂ emissions.

Therefore, with this purchase you are making a conscious choice to protect our planet.

So, go ahead and get to work!



Two people are required to assemble the product



The average assembly time can be between 2 hours for the smaller models and 10-12 hours for the larger ones

RECOMMENDATIONS PRIOR TO ASSEMBLY

You have a period of 24 hours from the reception of the product to verify and communicate, if necessary, the lack or deterioration of any of the parts of the package. If the plastic wrapping or the product itself is damaged on receipt, please contact the distributor immediately.

Once the black protective plastic has been removed, assembly of the product must begin within 48 hours. If this is not done, it is possible that the wood may change its dimensions, making it impossible to assemble the product. It is necessary to treat all the wooden parts of the product with Lasur to protect them from humidity, UV rays and the action of insects and fungi. It is recommended to apply the treatment to both the inside and outside of the product and to carry out regular maintenance.

The product is not designed to be installed directly on the lawn. We recommend installation on a level and firm base of wood, a flat concrete floor or cemented bricks or blocks. If a concrete pad is made it is important that it is sloped towards the edges to prevent water ingress. It is very important to fix the product to the ground. It does not include screws or other parts necessary for anchoring.

MAINTENANCE

The roof must be kept free of debris, as the weight on top of it can damage your product.

The roof tarpaulin is a wear product, so it should be inspected often and replaced as soon as necessary.

Do not store chemical, combustible and/or corrosive products inside.

WARRANTY

This product is manufactured with the best materials and under strict quality controls and standards. If you detect any problem with the product you have purchased, please contact our customer service department at the telephone number and email address given on the back cover of this instruction manual.

The warranty is valid from the date of purchase shown on the receipt or invoice, which must be presented to make use of the warranty.

The warranty period for this product varies depending on the legal regulations applicable in the country of purchase. Please refer to the regulations in force in the country of purchase for more information.

EXCLUDED FROM THE WARRANTY:

There are certain causes that are excluded from the warranty such as:

- > If there is a transport non-conformity, the transport agency must be notified within 24 hours of delivery.
- > Breakage or damage caused by inclement weather.
- > Incorrect assembly, incorrect use and the consequences of this.

In addition, you can consult the complete list of these three by scanning the QR on the box.

TOOLS REQUIRED FOR ASSEMBLY



MANUAL DE INSTRUCCIONES

Antes de comenzar...

Queremos agradecerte que hayas elegido uno de nuestros productos. El proceso de montaje puede requerir un poco de paciencia y tiempo, pero no te preocupes ¡estamos aquí para animarte! 😊

Una vez que termines piensa en la satisfacción y orgullo que sentirás al ver tu trabajo terminado y saber que lo has hecho tú mismo. Además, al montarlo estás haciendo una contribución al medio ambiente. ¿Cómo? Al no ser entregado completamente armado, se utiliza menos embalaje, lo que significa menos residuos y menos desperdicio. De esta manera cada producto ocupa menos espacio y por lo tanto se aprovecha al máximo los medios de transporte reduciendo de esta manera las emisiones de CO₂.

Por lo tanto, con esta compra estás haciendo una elección consciente para proteger nuestro planeta.

Ahora sí... ¡Adelante y manos a la obra!



Son necesarias dos personas para el montaje del producto



El tiempo medio de montaje puede estar entre las 2h de los modelos más pequeños a las 10-12h de los más grandes

RECOMENDACIONES PREVIAS AL MONTAJE

Tienes un plazo de 24h desde la recepción del producto para verificar y comunicar, si es necesario, la falta o el deterioro de alguna de las piezas del paquete. En caso de que el plástico que envuelve el producto o el propio producto sufran algún daño a la recepción, comunícalo con el distribuidor inmediatamente.

Una vez retirado el plástico negro protector, se debe comenzar con el montaje del producto antes de 48h. De no ser así, es posible que la madera modifique sus dimensiones llegando a impedir su montaje. Es necesario tratar todas las piezas de madera del producto con Lasur para protegerlas de la humedad, los rayos UV y de la acción de insectos y hongos. Se recomienda aplicar el tratamiento tanto en el interior como en el exterior del producto y realizar mantenimientos periódicamente.

El producto no está diseñado para ser instalado directamente sobre el césped. Recomendamos el montaje sobre una base nivelada y firme de madera, un suelo llano de cemento o ladrillos o bloques cementados. Si se hace una plataforma de cemento es importante que se incline hacia los bordes para evitar la entrada de agua. Es muy importante fijar el producto al suelo. No incluye tornillos ni otras piezas necesarias para su anclaje.

MANTENIMIENTO

El techo debe mantenerse limpio de residuos, ya que el peso en la parte superior puede deteriorar tu producto.

La tela asfáltica del tejado es un producto de desgaste, por lo que se debe inspeccionar a menudo y sustituir en cuanto sea necesario.

No guarde productos químicos, combustibles y/o corrosivos en su interior.

GARANTÍA

Este producto está fabricado con los mejores materiales y bajo estrictos controles y estándares de calidad. En caso de detectar algún inconveniente en el producto adquirido, rogamos te pongas en contacto con el servicio de atención al cliente en el teléfono y email que aparecen descritos en la contraportada de este manual de instrucciones.

La garantía es válida a partir de compra que aparece en el ticket o factura, el cual deberá presentarse para hacer uso de la garantía.

El periodo de garantía de este producto varía en función de la normativa legal aplicable en el país de compra. Consulte la normativa vigente del país para más información.

QUEDAN EXCLUIDAS DE LA GARANTÍA:

Hay ciertas causas que quedan excluidas de la garantía como:

- > Si existe una no conformidad del transporte, hay que comunicárselo a la agencia de transportes antes de que transcurran 24h desde la entrega.
- > Las roturas o daños generados por inclemencias meteorológicas.
- > El mal montaje, uso incorrecto y consecuencias derivadas de ello.

Además, de estas tres puedes consultar la lista completa en escaneando el QR de la caja.

HERRAMIENTAS
NECESARIAS PARA
SU MONTAJE



MANUAL DE INSTRUÇÕES

Antes de começarmos...

Queremos agradecer-lhe por ter escolhido um dos nossos produtos. O processo de montagem pode exigir um pouco de paciência e tempo, mas não se preocupe, estamos aqui para o encorajar! 😊

Quando terminar, pense na satisfação e no orgulho que sentirá quando vir o seu trabalho acabado e souber que foi feito por si. Além disso, ao montá-lo, está a contribuir para o ambiente. Como? Ao não ser entregue totalmente montado, são utilizadas menos embalagens, o que significa menos resíduos e menos desperdício. Desta forma, cada produto ocupa menos espaço e, por conseguinte, aproveita-se ao máximo os meios de transporte, reduzindo assim as emissões de CO₂. Portanto, com esta compra, está a fazer uma escolha consciente para proteger o nosso planeta.

Por isso, ponha mãos à obra!



São necessárias duas pessoas para montar o produto



O tempo médio de montagem pode ser de 2 horas para os modelos mais pequenos e de 10 a 12 horas para os modelos maiores

RECOMENDAÇÕES ANTES DA MONTAGEM

Dispõe de um prazo de 24 horas a partir da receção do produto para verificar e comunicar, se necessário, a falta ou a deterioração de qualquer parte da embalagem. Se o invólucro de plástico ou o próprio produto estiver danificado no momento da receção, contactar imediatamente o distribuidor.

Uma vez retirado o plástico protetor preto, a montagem do produto deve ser iniciada no prazo de 48 horas. Se tal não for feito, é possível que a madeira modifique as suas dimensões e até impeça a sua montagem. É necessário tratar todas as partes de madeira do produto com Lasur para as proteger da humidade, dos raios UV e da ação de insectos e fungos. Recomenda-se a aplicação do tratamento tanto no interior como no exterior do produto e a realização de uma manutenção regular.

O produto não foi concebido para ser instalado diretamente no relvado. Recomenda-se a instalação sobre uma base nivelada e firme de madeira, um pavimento plano de betão ou tijolos ou blocos cimentados. Se for feita uma base de betão, é importante que esta seja inclinada em direção às extremidades para evitar a entrada de água. É muito importante fixar o produto ao solo. Não inclui parafusos ou outras peças necessárias para a fixação.

MANUTENÇÃO

O tejadilho deve ser mantido livre de detritos, uma vez que o peso em cima pode danificar o seu produto.

A lona do tejadilho é um produto de desgaste, pelo que deve ser inspeccionada frequentemente e substituída logo que necessário. Não armazenar produtos químicos, combustíveis e/ou corrosivos no interior.

GARANTIA

Este produto é fabricado com os melhores materiais e sob rigorosos controlos e normas de qualidade. Se detetar algum problema com o produto que adquiriu, contacte o nosso serviço de apoio ao cliente através do número de telefone e do endereço de correio eletrónico indicados na contracapa deste manual de instruções.

A garantia é válida a partir da data de compra indicada no recibo ou na fatura, que deve ser apresentada para poder usufruir da garantia.

O período de garantia deste produto varia consoante os regulamentos legais aplicáveis no país de compra. Para mais informações, consultar a regulamentação em vigor no país de compra.

EXCLUÍDOS DA GARANTIA:

Existem determinadas causas que estão excluídas da garantia, tais como:

- > Se houver uma não-conformidade de transporte, a agência de transporte deve ser notificada no prazo de 24 horas após a entrega.
- > Quebra ou danos causados por intempéries.
- > Montagem incorrecta, utilização incorrecta e respectivas consequências.

Para além disso, pode consultar a lista completa destas três advertências através da leitura do QR na caixa.

**FERRAMENTAS
NECESSÁRIAS
PARA A MONTAGEM**



MANUEL D'INSTRUCTIONS

Avant de commencer...

Nous tenons à vous remercier d'avoir choisi l'un de nos produits. Le processus d'assemblage peut nécessiter un peu de patience et de temps, mais ne vous inquiétez pas, nous sommes là pour vous encourager ! 😊

Une fois que vous aurez terminé, pensez à la satisfaction et à la fierté que vous ressentirez lorsque vous verrez votre œuvre terminée et que vous saurez que vous l'avez faite vous-même. De plus, en l'assemblant, vous contribuez à la protection de l'environnement. Comment? En n'étant pas livré entièrement assemblé, moins d'emballages sont utilisés, ce qui signifie moins de déchets et moins de gaspillage. De cette manière, chaque produit prend moins de place et vous exploitez au maximum les moyens de transport, réduisant ainsi les émissions de CO₂.

Avec cet achat, vous faites donc un choix conscient pour protéger notre planète.

Alors, n'hésitez plus et mettez-vous au travail !



Deux personnes sont nécessaires pour assembler le produit



Le temps de montage moyen peut être de 2 heures pour les petits modèles et de 10 à 12 heures pour les plus grands

RECOMMANDATIONS AVANT L'ASSEMBLAGE

Vous disposez d'un délai de 24 heures à compter de la réception du produit pour vérifier et communiquer, le cas échéant, l'absence ou la détérioration de l'une des parties de l'emballage. Si l'emballage plastique ou le produit lui-même est endommagé à la réception, veuillez contacter immédiatement le distributeur.

Une fois le plastique noir de protection retiré, l'assemblage du produit doit commencer dans les 48 heures. Dans le cas contraire, il est possible que le bois modifie ses dimensions et empêche même son montage. Il est nécessaire de traiter toutes les parties en bois du produit avec du Lasur pour les protéger de l'humidité, des rayons UV et de l'action des insectes et des champignons. Il est recommandé d'appliquer le traitement à l'intérieur et à l'extérieur du produit et d'effectuer un entretien régulier.

Le produit n'est pas conçu pour être installé directement sur la pelouse. Nous recommandons de l'installer sur une base plane et ferme en bois, sur un sol plat en béton ou sur des briques ou des blocs cimentés. Si un socle en béton est réalisé, il est important qu'il soit incliné vers les bords afin d'éviter les infiltrations d'eau. Il est très important de fixer le produit au sol. Les vis et autres éléments nécessaires à l'ancrage ne sont pas inclus.

ENTRETIEN

Le toit doit être dégagé de tout débris, car le poids qui s'y trouve peut endommager votre produit.

La bache de toit est un produit d'usure, il faut donc l'inspecter souvent et la remplacer dès que nécessaire.

Ne pas stocker de produits chimiques, combustibles et/ou corrosifs à l'intérieur.

GARANTIE

Ce produit est fabriqué avec les meilleurs matériaux et selon des normes et des contrôles de qualité stricts. Si vous constatez un problème quelconque avec le produit que vous avez acheté, veuillez contacter notre service clientèle au numéro de téléphone et à l'adresse électronique indiqués au dos de ce manuel d'instructions.

La garantie est valable à partir de la date d'achat indiquée sur le ticket de caisse ou la facture, qui doivent être présentés pour pouvoir bénéficier de la garantie.

La période de garantie de ce produit varie en fonction des dispositions légales applicables dans le pays d'achat. Pour plus d'informations, veuillez vous référer à la réglementation en vigueur dans le pays d'achat.

EXCLUS DE LA GARANTIE:

Certaines causes sont exclues de la garantie:

- > En cas de non-conformité du transport, l'agence de transport doit être informée dans les 24 heures suivant la livraison.
- > Le bris ou les dommages causés par les intempéries.
- > Un mauvais montage, une mauvaise utilisation et les conséquences qui en découlent.

En outre, vous pouvez consulter la liste complète de ces trois éléments en scannant le QR sur la boîte.

**OUTILS
NÉCESSAIRES À
L'ASSEMBLAGE**



GEBRAUCHSANWEISUNG

Bevor wir beginnen...

Wir möchten Ihnen danken, dass Sie sich für eines unserer Produkte entschieden haben. Der Zusammenbau kann ein wenig Geduld und Zeit erfordern, aber keine Sorge, wir sind hier, um Sie zu unterstützen! 😊

Denken Sie an die Genugtuung und den Stolz, die Sie empfinden werden, wenn Sie Ihr fertiges Werk sehen und wissen, dass Sie es selbst gemacht haben. Außerdem leisten Sie durch den Zusammenbau einen Beitrag zum Umweltschutz: Da das Produkt nicht komplett zusammengebaut geliefert wird, wird weniger Verpackung verwendet, was wiederum weniger Abfall bedeutet und weniger Müll. Auf diese Weise nimmt jedes Produkt weniger Platz ein, und Sie nutzen die Transportmittel optimal aus, wodurch die CO₂-Emissionen verringert werden.

Mit diesem Kauf treffen Sie also eine bewusste Entscheidung für den Schutz unseres Planeten.

Und jetzt... an die Arbeit!



Für den Zusammenbau des Produkts werden zwei Personen benötigt



Die durchschnittliche Montagezeit kann zwischen 2 Stunden für die kleineren Modelle und 10-12 Stunden für die größeren Modelle liegen

🗨 EMPFEHLUNGEN VOR DER MONTAGE

Sie haben eine Frist von 24 Stunden ab Erhalt des Produkts, um das Fehlen oder die Beschädigung von Teilen der Verpackung zu überprüfen und gegebenenfalls zu melden. Sollte die Plastikverpackung oder das Produkt selbst beim Empfang beschädigt sein, wenden Sie sich bitte sofort an den Händler.

Sobald die schwarze Schutzfolie entfernt wurde, muss innerhalb von 48 Stunden mit dem Zusammenbau des Produkts begonnen werden. Andernfalls ist es möglich, dass das Holz seine Abmessungen verändert und sogar den Zusammenbau verhindert. Es ist notwendig, alle Holzteile des Produkts mit Lasur zu behandeln, um sie vor Feuchtigkeit, UV-Strahlen und Insekten- und Pilzbefall zu schützen. Es wird empfohlen, das Produkt sowohl innen als auch außen mit Lasur zu behandeln und eine regelmäßige Wartung durchzuführen.

Das Produkt ist nicht für die direkte Verlegung auf dem Rasen vorgesehen. Wir empfehlen die Installation auf einem ebenen und festen Untergrund aus Holz, einem flachen Betonboden oder zementierten Ziegeln oder Blöcken. Bei einer Betonunterlage ist es wichtig, dass sie zu den Rändern hin abgeschrägt ist, um das Eindringen von Wasser zu verhindern. Es ist sehr wichtig, das Produkt auf dem Boden zu befestigen. Schrauben oder andere für die Verankerung erforderliche Teile sind nicht im Lieferumfang enthalten.

🔧 WARTUNG

Das Dach muss frei von Ablagerungen gehalten werden, da das Gewicht auf dem Dach Ihr Produkt beschädigen kann. Die Dachplane ist ein Verschleißprodukt, daher sollte sie häufig überprüft und bei Bedarf ausgetauscht werden. Lagern Sie keine chemischen, brennbaren und/oder ätzenden Produkte darin.

🛡 GARANTIE

Dieses Produkt wird mit den besten Materialien und unter strengen Qualitätskontrollen und -standards hergestellt. Sollten Sie ein Problem mit dem von Ihnen erworbenen Produkt feststellen, wenden Sie sich bitte an unseren Kundendienst unter der auf der Rückseite dieser Bedienungsanleitung angegebenen Telefonnummer und E-Mail-Adresse.

Die Garantie gilt ab dem Kaufdatum, das auf dem Kaufbeleg oder der Rechnung angegeben ist, die für die Inanspruchnahme der Garantie vorgelegt werden muss.

Die Garantiezeit für dieses Produkt variiert je nach den gesetzlichen Bestimmungen des Landes, in dem es gekauft wurde. Bitte informieren Sie sich über die im Land des Kaufs geltenden Vorschriften.

⚙ VON DER GARANTIE AUSGESCHLOSSEN:

Es gibt bestimmte Ursachen, die von der Garantie ausgeschlossen sind, wie z.B.:

- > Bei Transportfehlern muss das Transportunternehmen innerhalb von 24 Stunden nach der Lieferung benachrichtigt werden.
- > Bruch oder Beschädigung durch schlechtes Wetter.
- > Unsachgemäße Montage, unsachgemäße Verwendung und die daraus resultierenden Folgen.

Darüber hinaus können Sie die vollständige Liste dieser drei Punkte durch Scannen des QR-Codes auf der Verpackung einsehen.

**FÜR DIE MONTAGE
ERFORDERLICHE
WERKZEUGE**



ΕΓΧΕΙΡΙΔΙΟ ΧΡΗΣΤΗ

Πριν ξεκινήσουμε...

Θέλουμε να σας ευχαριστήσουμε που επιλέξατε ένα από τα προϊόντα μας. Η διαδικασία συναρμολόγησης μπορεί να απαιτεί λίγη υπομονή και χρόνο, αλλά μην ανησυχείτε, είμαστε εδώ για να σας ενθαρρύνουμε! 😊

Μόλις τελειώσετε, σκεφτείτε την ικανοποίηση και την υπερηφάνεια που θα νιώσετε όταν δείτε το τελικό σας έργο και ξέρετε ότι το κάνατε μόνοι σας. Επίσης, με τη συναρμολόγησή του συμβάλλετε στο περιβάλλον. Πώς; Με το να μην παραδίδεται πλήρως συναρμολογημένο, χρησιμοποιείται λιγότερη συσκευασία, πράγμα που σημαίνει λιγότερα απόβλητα και λιγότερα απορρίμματα. Με αυτόν τον τρόπο κάθε προϊόν καταλαμβάνει λιγότερο χώρο και επομένως αξιολύτως στο έπακρο τα μέσα μεταφοράς, μειώνοντας έτσι τις εκπομπές CO₂.

Επομένως, με αυτή την αγορά κάνετε μια συνειδητή επιλογή για την προστασία του πλανήτη μας.

Προχωρήστε λοιπόν και πιάστε δουλειά!



Για τη συναρμολόγηση του προϊόντος απαιτούνται δύο άτομα



Ο μέσος χρόνος συναρμολόγησης μπορεί να κυμαίνεται μεταξύ 2 ωρών για τα μικρότερα μοντέλα και 10-12 ωρών για τα μεγαλύτερα

☞ ΣΥΣΤΑΣΕΙΣ ΠΡΙΝ ΑΠΟ ΤΗ ΣΥΝΑΡΜΟΛΟΓΗΣΗ

Έχετε στη διάθεσή σας μια περίοδο 24 ωρών από την παραλαβή του προϊόντος για να ελέγξετε και να κοινοποιήσετε, εάν είναι απαραίτητο, την έλλειψη ή τη φθορά οποιουδήποτε από τα μέρη της συσκευασίας. Εάν το πλαστικό περιτύλιγμα ή το ίδιο το προϊόν έχει υποστεί ζημιά κατά την παραλαβή, επικοινωνήστε αμέσως με τον διανομέα.

Μετά την αφαίρεση του μαύρου προστατευτικού πλαστικού, η συναρμολόγηση του προϊόντος πρέπει να ξεκινήσει εντός 48 ωρών. Εάν αυτό δεν γίνει, είναι πιθανό το ξύλο να τροποποιησει τις διαστάσεις του και να εμποδίσει ακόμη και τη συναρμολόγησή του. Είναι απαραίτητη η επεξεργασία όλων των ξύλινων μερών του προϊόντος με Lasur για την προστασία τους από την υγρασία, τις ακτίνες UV και τη δράση εντόμων και μυκήτων. Συνιστάται η εφαρμογή της επεξεργασίας τόσο στο εσωτερικό όσο και στο εξωτερικό του προϊόντος και η τακτική συντήρησή του.

Το προϊόν δεν έχει σχεδιαστεί για να εγκατασταθεί απευθείας στο γκαζόν. Συνιστούμε την εγκατάσταση σε επίπεδη και σταθερή βάση από ξύλο, επίπεδο δάπεδο από σκυρόδεμα ή τσιμεντοποιημένα τούβλα ή τούβλα. Εάν γίνει βάση από σκυρόδεμα, είναι σημαντικό να έχει κλίση προς τις άκρες για να αποτρέπεται η εισροή νερού. Είναι πολύ σημαντικό να στερεωθεί το προϊόν στο έδαφος. Δεν περιλαμβάνει βίδες ή άλλα μέρη που είναι απαραίτητα για την αγκύρωση.

🔧 ΣΥΝΤΗΡΗΣΗ

Η οροφή πρέπει να διατηρείται καθαρή από σκουπίδια, καθώς το βάρος που πέφτει πάνω της μπορεί να προκαλέσει ζημιά στο προϊόν σας.

Οι μουςαμιάς οροφής είναι προϊόν φθοράς, επομένως θα πρέπει να επιθεωρείται συχνά και να αντικαθίσταται μόλις χρειαστεί. Μην αποθηκεύετε χημικά, εύφλεκτα ή/και διαβρωτικά προϊόντα στο εσωτερικό της.

🔩 ΕΓΓΥΗΣΗ

Αυτό το προϊόν κατασκευάζεται με τα καλύτερα υλικά και κάτω από αυστηρούς ποιοτικούς ελέγχους και πρότυπα. Εάν εντοπίσετε οποιοδήποτε πρόβλημα με το προϊόν που αγοράσατε, παρακαλούμε επικοινωνήστε με το τμήμα εξυπηρέτησης πελατών μας στον αριθμό τηλεφώνου και τη διεύθυνση ηλεκτρονικού ταχυδρομείου που αναφέρονται στο οπισθόφυλλο του παρόντος εγχειριδίου οδηγιών χρήσης.

Η εγγύηση ισχύει από την ημερομηνία αγοράς που αναγράφεται στην απόδειξη ή το τιμολόγιο, τα οποία πρέπει να προσκομιστούν για να κάνετε χρήση της εγγύησης.

Η περίοδος εγγύησης για αυτό το προϊόν ποικίλλει ανάλογα με τους νομικούς κανονισμούς που ισχύουν στη χώρα αγοράς. Για περισσότερες πληροφορίες ανατρέξτε στους κανονισμούς που ισχύουν στη χώρα αγοράς.

⚠️ ΕΞΑΙΡΟΥΝΤΑΙ ΑΠΟ ΤΗΝ ΕΓΓΥΗΣΗ:

Υπάρχουν ορισμένες αιτίες που εξαιρούνται από την εγγύηση, όπως:

- > Εάν υπάρχει μη συμμόρφωση κατά τη μεταφορά, το πρακτορείο μεταφοράς πρέπει να ειδοποιηθεί εντός 24 ωρών από την παράδοση.
- > Σπάσιμο ή ζημιά που προκαλείται από κακές καιρικές συνθήκες.
- > Λανθασμένη συναρμολόγηση, λανθασμένη χρήση και οι συνέπειες αυτής.

Επιπλέον, μπορείτε να συμβουλευτείτε τον πλήρη κατάλογο αυτών των τριών, σαρώνοντας το QR στο κομμάτι.

ΕΡΓΑΛΕΙΑ ΠΟΥ ΑΠΑΙΤΟΥΝΤΑΙ ΓΙΑ ΤΗ ΣΥΝΑΡΜΟΛΟΓΗΣΗ



MANUALE DI ISTRUZIONI

Prima di iniziare...

Vogliamo ringraziarvi per aver scelto uno dei nostri prodotti. Il processo di assemblaggio può richiedere un po' di pazienza e di tempo, ma non preoccupatevi, siamo qui per incoraggiarvi! 😊

Una volta terminato, pensate alla soddisfazione e all'orgoglio che proverete quando vedrete il vostro lavoro finito e saprete di averlo fatto da soli. Inoltre, assemblandolo, darete un contributo all'ambiente. In che modo? Non essendo consegnato completamente assemblato, si utilizzano meno imballaggi, il che significa meno rifiuti e meno scarti. In questo modo ogni prodotto occupa meno spazio e quindi si sfruttano al meglio i mezzi di trasporto, riducendo così le emissioni di CO₂. Pertanto, con questo acquisto si fa una scelta consapevole per proteggere il nostro pianeta.

Quindi, andate avanti e mettetevi al lavoro!



Per assemblare il prodotto sono necessarie due persone



Il tempo medio di montaggio può variare da 2 ore per i modelli più piccoli a 10-12 ore per quelli più grandi

🗨️ RACCOMANDAZIONI PRIMA DEL MONTAGGIO

Avete un periodo di 24 ore dal ricevimento del prodotto per verificare e comunicare, se necessario, la mancanza o il deterioramento di una qualsiasi delle parti dell'imballaggio. Se l'involucro di plastica o il prodotto stesso risultano danneggiati al momento del ricevimento, contattare immediatamente il distributore.

Una volta rimossa la plastica protettiva nera, il montaggio del prodotto deve iniziare entro 48 ore. In caso contrario, è possibile che il legno modifichi le sue dimensioni e impedisca il montaggio. È necessario trattare tutte le parti in legno del prodotto con Lasur per proteggerle dall'umidità, dai raggi UV e dall'azione di insetti e funghi. Si raccomanda di applicare il trattamento sia all'interno che all'esterno del prodotto e di effettuare una manutenzione regolare.

Il prodotto non è stato progettato per essere installato direttamente sul prato. Si consiglia il montaggio su una base piana e solida di legno, su un pavimento piatto di cemento o su mattoni o blocchi cementati. Se si realizza una base in cemento, è importante che sia inclinata verso i bordi per evitare l'ingresso di acqua. È molto importante fissare il prodotto al suolo. Non sono incluse viti o altre parti necessarie per l'ancoraggio.

🔧 MANUTENZIONE

Il tetto deve essere mantenuto libero da detriti, poiché il peso che vi grava sopra può danneggiare il prodotto.

Il telo del tetto è un prodotto soggetto a usura, pertanto deve essere ispezionato spesso e sostituito non appena necessario. Non conservare all'interno prodotti chimici, combustibili e/o corrosivi.

🛡️ GARANZIA

Questo prodotto è realizzato con i migliori materiali e in base a rigorosi controlli e standard di qualità. Se si riscontrano problemi con il prodotto acquistato, si prega di contattare il nostro servizio clienti al numero di telefono e all'indirizzo e-mail riportati sul retro della copertina di questo manuale di istruzioni.

La garanzia è valida a partire dalla data di acquisto riportata sullo scontrino o sulla fattura, che deve essere presentata per usufruire della garanzia.

Il periodo di garanzia per questo prodotto varia a seconda delle norme legali applicabili nel paese di acquisto. Per ulteriori informazioni, consultare le norme vigenti nel Paese di acquisto.

⚙️ ESCLUSE DALLA GARANZIA:

Ci sono alcune cause che sono escluse dalla garanzia, come ad esempio:

- > In caso di non conformità dovuta al trasporto, l'agenzia di trasporto deve essere informata entro 24 ore dalla consegna.
- > Rotture o danni causati da intemperie.
- > Montaggio non corretto, uso non corretto e relative conseguenze.

Inoltre, è possibile consultare l'elenco completo di questi tre elementi scansionando il QR sulla scatola.

**STRUMENTI
NECESSARI PER IL
MONTAGGIO**



NÁVOD NA POUŽITIE

Predtým, ako začneme...

Ďakujeme za kúpu jedného z našich produktov. Proces montáže môže vyžadovať trochu trpezlivosti a času, no my sme tu na to, aby sme vám s tým pomohli! 😊

Myslite na uspokojenie a pýchu, ktorú pocítite pri pohľade na vlastnoručne dokončenú prácu. Navyše, montážou pomáhate životnému prostrediu. Ako? Dodanie čiastočne rozloženého produktu vyžaduje menej obalového materiálu a menej odpadu. Týmto spôsobom sa obmedzuje aj veľkosť produktov, a tým sa prispieva k úplnému využitiu priestoru v dopravných prostriedkoch a zníženiu CO₂.

Táto kúpa reprezentuje vašu uvedomelú voľbu na ochranu planéty.

Teraz sa už môžete pustiť do práce!



Na montáž produktu sú potrebné dve osoby



Čas montáže sa pohybuje medzi 2 hodinami, v prípade malých modelov, a 10 – 12 hodinami pri najväčších produktoch

ODPORÚČANIA PRED ZAČATÍM MONTÁŽE

Od doručenia produktu máte 24 hodín čas na overenie a prípadné nahlásenie chýbajúcich alebo poškodených dielov v balíku. V prípade poškodenia plastových obalov alebo samotného produktu už pri doručení okamžite kontaktujte predajcu.

Po odstránení čierneho plastového obalu by ste mali začať s montážou najneskôr do 48 hodín. V opačnom prípade je možné, že drevo zmení svoje rozmery a znemožní tak montáž. Je nevyhnutné ošetriť všetky drevené časti produktu lazúrou, ktorá ich ochráni pred vlhkosťou, ultrafialovým žiarením a pôsobením hmyzu a plesní. Odporúčame ošetriť vnútornú aj vonkajšiu stranu produktu a pravidelne ich udržiavať.

Výrobok nie je určený na inštaláciu priamo na trávnik. Odporúčame montáž na rovný a pevný drevený podklad, rovnú podlahu z betónu, tehliel či tvárnic. Pri stavbe betónového podkladu je dôležité jeho naklonenie smerom k okrajom, aby sa vyhlo hromadeniu vody. Je dôležité pripevniť produkt k podkladu. Balenie neobsahuje skrutky ani iné súčiastky na jeho ukotvenie.

ÚDRŽBA

Udržujte strechu produktu bez záťaže, pretože tá by mohla spôsobiť jej poškodenie.

Asfaltová strešná krytina sa opotrebuje. Vykonávajte jej častú kontrolu a v prípade potreby ju vymeňte.

Vo vnútri produktu neskladujte chemikálie, horľavé a/alebo oxidačné látky.

ZÁRUKA

Tento produkt je vyrobený z najlepších materiálov podľa prísnych kontrol a štandardov kvality. Ak zistíte akékoľvek problémy so zakúpeným výrobkom, obráťte sa na oddelenie služieb zákazníkom na telefónnom čísle a e-mailovej adrese uvedenej na zadnej strane tohto návodu na použitie.

Záruka je platná od dátumu nákupu uvedeného na účtenke alebo faktúre, ktorú je potrebné predložiť na uplatnenie záruky. Záručná doba na tento výrobok sa líši v závislosti od právnych predpisov platných v krajine nákupu. Ďalšie informácie nájdete v právnych predpisoch príslušnej krajiny.

SÚ ZO ZÁRUKY VYLÚČENÉ:

Existujú určité príčiny, ktoré sú zo záruky vylúčené, ako napríklad:

- > Ak sa vyskytne nehoda pri preprave, prepravná spoločnosť musí byť informovaná do 24 hodín od doručenia.
- > Rozbitie alebo poškodenie spôsobené nepriaznivým počasím.
- > Nesprávna montáž, nesprávne používanie a ich dôsledky.

Kompletný zoznam týchto prípadov si môžete pozrieť naskenovaním kódu QR na škatuli.

**NÁRADIE
POTREBNÉ NA
MONTÁŽ**



PRIRUČNIK

Prije no što započnete...

Hvala vam što ste odabrali jedan od naših proizvoda. Za proces montaže možda je potrebno nešto strpljenja i vremena, ali ne brinite se: ovdje smo da vam pomognemo! 😊

Pomislite na zadovoljstvo i ponos koje ćete osjetiti kad završite i vidite da je vaš posao gotov i da ste ga sami napravili. Osim toga, montažom pomažete okolišu. Kako? S obzirom na to da se ne isporučuje u gotovom stanju, troši se manje ambalaže, što znači manje otpadaka i smeća. Na ovaj način svaki proizvod zauzima manje prostora, zbog čega se prijevozna sredstva maksimalno iskorištavaju, čime se smanjuje emisija CO₂.

Stoga vi ovom kupnjom svjesno odlučujete zaštititi naš planet.

A sada... Na posao!



Za montažu proizvoda potrebne su dvije osobe



Prosječno vrijeme montaže može biti od 2 h za najmanje modele do 10-12 h za najveće

PREPORUKE PRIJE MONTAŽE

Imate rok od 24 sata od primitka proizvoda da provjerite i ako je potrebno prijavite nedostatak ili oštećenje bilo kojeg dijela paketa. U slučaju da plastika u koju je proizvod umotan ili sam proizvod pretrpi bilo kakvu štetu pri primitku, odmah se obratite distributeru.

Nakon što se ukloni zaštitna crna plastika, montaža proizvoda mora započeti unutar 48 sati. U suprotnom je moguće da drvo promijeni dimenzije, što može onemogućiti montažu. Svi drveni dijelovi proizvoda moraju se tretirati Lasurom kako bi ih zaštitili od vlage, UV zraka te djelovanja insekata i gljivica. Preporučuje se tretman primijeniti i s unutarnje i s vanjske strane proizvoda te provoditi redovito održavanje.

Proizvod nije namijenjen za travnjak kao izravnu podlogu. Preporučujemo montažu na čvrstoj, ravnoj drvenoj podlozi, ravnoj betonskoj podlozi ili podlozi od cementiranih opeka ili ploča. Ako se radi betonska platforma važno je da ona ima nagib prema rubovima kako bi se izbjegao prodor vode. Vrlo je važno pričvrstiti proizvod za pod. Nisu uključeni vijci ni drugi dijelovi potrebni za pričvršćivanje.

ODRŽAVANJE

Krov se mora čistiti od otpadaka jer težina u gornjem dijelu može oštetiti vaš proizvod.

Krovni filc je proizvod koji se troši, pa ga treba često pregledavati i po potrebi mijenjati.

Unutra nemojte skladištiti kemijske, zapaljive i/ili korozivne proizvode.

JAMSTVO

Ovaj proizvod izrađen je od vrhunskih materijala i pod strogim kontrolama i standardima kvalitete. U slučaju bilo kakvih mana na kupljenom proizvodu, obratite se službi za kupce na broj telefona i e-mail koji su navedeni na poledini ovog priručnika za uporabu.

Jamstvo vrijedi od datuma kupnje koji se nalazi na potvrdi ili računu koji je potrebno predočiti za korištenje jamstva.

Razdoblje jamstva za ovaj proizvod varira ovisno o zakonskim propisima koji su na snazi u zemlji kupnje. Za više informacija proučite važeće propise.

U JAMSTVO NISU UKLJUČENI:

Neki uzroci nisu uključeni u jamstvo, kao:

- > U slučaju neadekvatnog transporta, treba obavijestiti agenciju za prijevoz prije no što prođu 24 sata od isporuke.
- > Lomovi ili oštećenja uzrokovani vremenskim nepogodama.
- > Loša montaža, nepravilna uporaba i njihove posljedice.

Osim ova tri, možete pregledati cijeli popis skeniranjem QR koda na kutiji.

**ALAT POTREBAN
ZA MONTAŽU**



NÁVOD K POUŽITÍ

Než začnete...

Chtěli bychom vám poděkovat, že jste si vybrali jeden z našich produktů. Montáž může vyžadovat trochu trpělivosti a času, ale nebojte se, jsme tu, abychom vám pomohli! 😊

Představte si, jaké uspokojení a hrdost pocítíte, až uvidíte produkt smontovaný a budete vědět, že jste jej smontovali vy sami. Navíc tím šetříte i životní prostředí. Proč? Díky tomu, že produkty nejsou dodávány kompletně smontované, spotřebovává se méně obalů, což znamená méně odpadu a zbytků. Každý výrobek tak zabírá méně místa a proto se dopravní prostředky maximálně využijí, čímž se snižují emise CO₂.

Tímto nákupem se tedy vědomě rozhodujete chránit naši planetu.

Tak a nyní... Jdeme na to!



K sestavení produktu jsou zapotřebí dvě osoby



Průměrná doba montáže může být 2 hodiny u nejmenších modelů a 10-12 hodin u největších

🗨️ DOPORUČENÍ PŘED MONTÁŽÍ

Máte k dispozici 24 hodin od obdržení produktu, abyste ověřili a případně sdělili možné nedostatky nebo poškození některé z částí balení. V případě, že plast, kterým je výrobek zabalen, nebo výrobek samotný jsou při převzetí poškozené, kontaktujte ihned distributora.

Po odstranění ochranného černého plastu musí být montáž výrobku zahájena do 48 hodin. V opačném případě je možné, že dřevo změní své rozměry a montáž nebude proveditelná. Všechny dřevěné části výrobku je nutné ošetřit Lasurem, aby byly chráněny před vlhkostí, UV zářením a působením hmyzu a plísní. Ošetření se doporučuje aplikovat uvnitř i vně výrobku a provádět pravidelnou údržbu.

Výrobek není určen k instalaci přímo na trávník. Doporučujeme jej umístit na pevný a rovný dřevěný podklad, rovnou cementovou podlahu nebo tmelené cihly či bloky. Pokud se jedná o cementovou plošinu, je důležité, aby se svažovala směrem k okrajům, aby se zabránilo vniknutí vody. Je velmi důležité připevnit výrobek k zemi. Neobsahuje šrouby ani jiné díly nutné k jeho ukotvení.

🔧 ÚDRŽBA

Na střeše nesmí zůstat žádné předměty, protože její zatížení by mohlo poškodit váš produkt.

Střešní plst je výrobek, který se opotřebovává, proto by měla být často kontrolována a podle potřeby je třeba ji vyměnit.

Neskladujte uvnitř chemické, hořlavé ani korozivní produkty.

🛡️ ZÁRUKA

Tento produkt je vyroben z nejlepších materiálů a byl podroben přísné kontrole kvality a norem. V případě, že u zakoupeného produktu zjistíte jakékoliv závady, kontaktujte prosím zákaznický servis na telefonním čísle a emailu, které jsou uvedeny na zadní straně tohoto návodu.

Záruka je platná od data nákupu uvedeného na stvrzence nebo faktuře, kterou je nutné předložit pro její uplatnění.

Záruční doba pro tento výrobek se liší v závislosti na právních předpisech platných v zemi nákupu. Další informace naleznete v aktuálních předpisech dané země.

🌟 ZÁRUKA SE NEUPLATŇUJE V NÁSLEDUJÍCÍCH PŘÍPADADECH:

Existují určité případy, kdy záruku nelze uplatnit, například:

- > V případě, že nejste spokojeni s přepravou, je nutné tuto skutečnost oznámit přepravní kanceláři do 24 hodin od doručení.
- > Při rozbití nebo poškození způsobeného nepřízní počasí
- > V případě špatného provedení montáže, nesprávného použití a z toho vyplývajících důsledků.

Kromě těchto tří důvodů existují další, jejichž kompletní seznam si můžete přečíst po naskenování QR kódu na krabici.

**NÁŘADÍ POTŘEBNÉ
K MONTÁŽÍ**



NAVODILA ZA UPORABO

Pred začetkom...

Želimo se vam zahvaliti, ker ste izbrali enega od naših izdelkov. Postopek montaže bo morda zahteval nekaj potrpljenja in časa, a ne skrbite, tukaj smo, da vam pomagamo! 😊

Ko končate z montažo, pomislite na zadovoljstvo in ponos, ki ju boste občutili, ko boste videli svoje delo dokončali in vse naredili sami. Poleg tega z montažo pozitivno prispevate k okolju. Kako? Ker izdelek ni dostavljen popolnoma montiran, se porabi manj embalaže, kar pomeni manj ostankov in manj odpadkov. Na ta način vsak izdelek zasede manj prostora in je zato prevozno sredstvo kar se da izkoriščeno, s čimer se zmanjšajo emisije CO₂.

Zato ste se s tem nakupom zavestno odločili za zaščito našega planeta.

Zdaj pa ... Kar na delo!



Za montažo izdelka sta potrebni dve osebi



Povprečni čas montaže je lahko med 2 urama za manjše modele in 10-12 ur za največje modele

🗨️ PRIPOROČILA PRED MONTAŽO

Od prejema izdelka imate na voljo 24 ur, da ga pregledate in po potrebi sporočite, ali kateri koli del paketa manjka ali je poškodovan. V primeru, da sta plastika, v katero je ovit izdelek, ali sam izdelek ob prevzemu poškodovana, se takoj obrnite na distributerja.

Ko je zaščitna črna plastika odstranjena, je treba začeti z montažo izdelka v roku 48 ur. V nasprotnem primeru lahko les spremeni svoje dimenzije, kar prepreči ustrezno montažo izdelka. Na vse lesene dele izdelka je treba nanesti zaščitni premaz Lasur, da jih zaščitimo pred vlago, UV žarki ter pred delovanjem insektov in gliv. Priporočljivo je, da zaščitni premaz nanesete na notranjo in zunanjo stran izdelka ter izvajate redno vzdrževanje.

Izdelek ni zasnovan za namestitvev neposredno na trato. Priporočamo, da se montaža opravi na trdni, ravni leseni podlagi, ravnih cementnih tleh ali na cementiranih opekah ali blokih. Če se izdelka cementna ploščad, je pomembno, da je nagnjena proti robovom, da se prepreči udor vode. Zelo pomembno je, da izdelek pritrдите na tla. Ne vključuje vijakov ali drugih delov, potrebnih za njegovo pritržitev.

🔧 ODRŽAVANJE

Na strehi ne sme biti ostankov, saj lahko njihova teža uniči vaš izdelek.

Strešna izolacija je izdelek, ki se obrabi, zato jo je treba pogosto pregledovati in po potrebi zamenjati.

V notranjosti ne shranjujte kemičnih, gorljivih in/ali jedkih izdelkov.

🛡️ GARANCIJA

Ta izdelek je narejen iz najboljših materialov ter pod strogimi nadzori in standardi glede kakovosti. V primeru, da pri kupljenem izdelku zaznate kakršne koli nevspečnosti, se obrnite na službo za pomoč strankam ter pokličite na telefonsko številko ali pišite na e-poštni naslov, ki sta navedena na zadnji platnici teh navodil za uporabo.

Garancija velja od datuma nakupa, ki je naveden na računu, ki ga morate predložiti za uveljavljanje garancije.

Garancijska doba za ta izdelek se razlikuje glede na pravne predpise, ki veljajo v državi nakupa. Za več informacij si oglejte trenutne predpise v državi nakupa.

🔍 IZ GARANCIJE JE IZVZETO NASLEDNJE:

Obstajajo določeni vzroki, ki so izključeni iz garancije, kot so:

- > Če pride do neskladij pri prevozu, je treba o tem obvestiti prevoznika v 24 urah po dostavi izdelka.
- > Zlomi ali poškodbe zaradi neugodnih vremenskih razmer
- > Slaba montaža, nepravilna uporaba in posledice, ki izhajajo iz tega.

Poleg teh treh vzrokov si lahko ogledate celoten seznam tako, da skenirate kodo QR na škatli.

**ORODJE,
POTREBNO ZA
MONTAŽO**



👁 ASSEMBLY · MONTAJE · MONTAGEM · MONTAGE · ΣΥΝΑΡΜΟΛΟΓΗΣΗ
MONTAGGIO · MONTÁŽ · MONTÁŽA

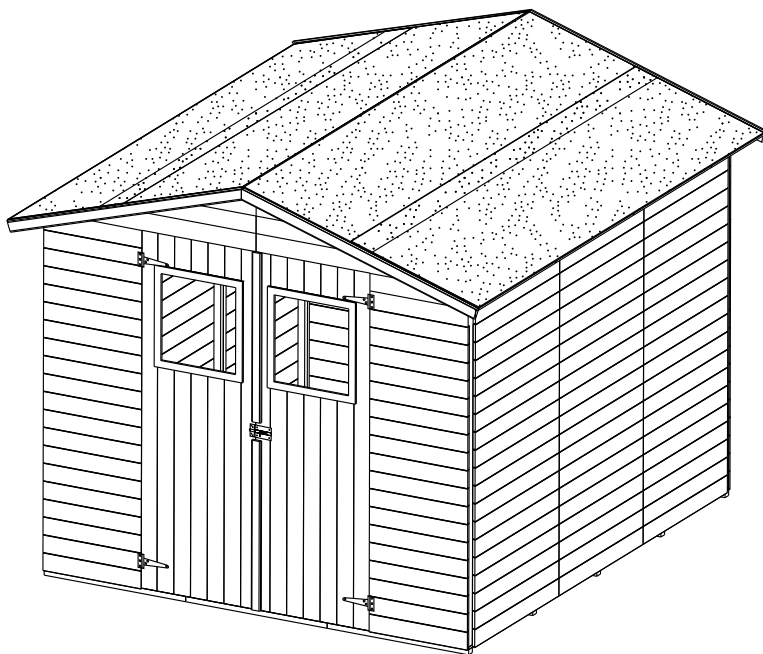

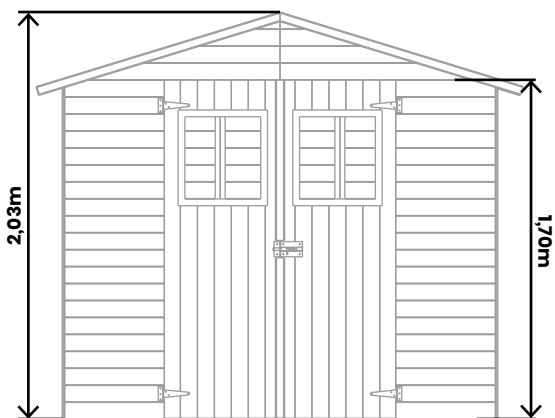
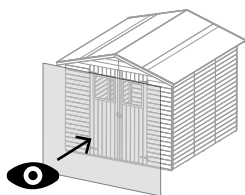
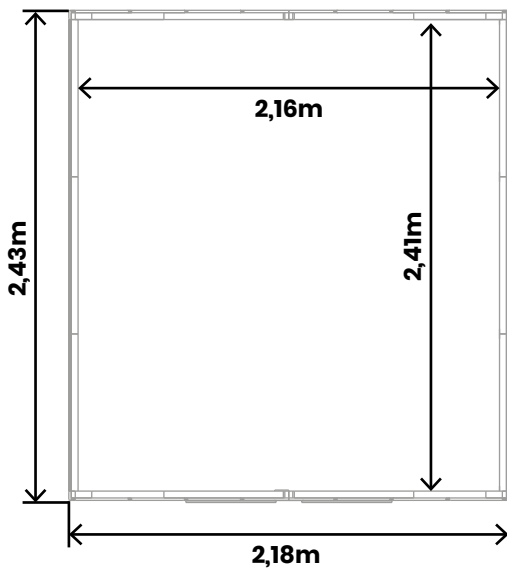
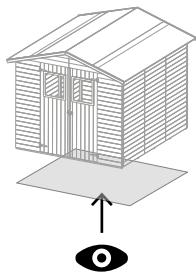

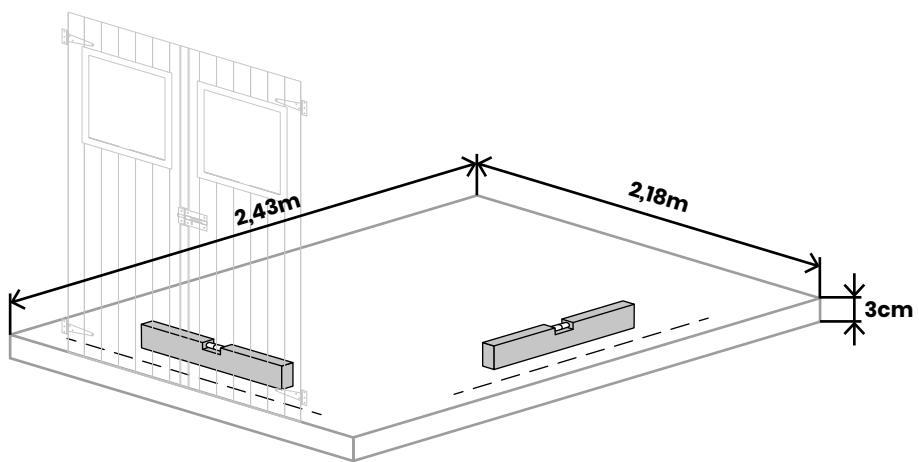
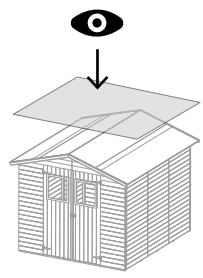
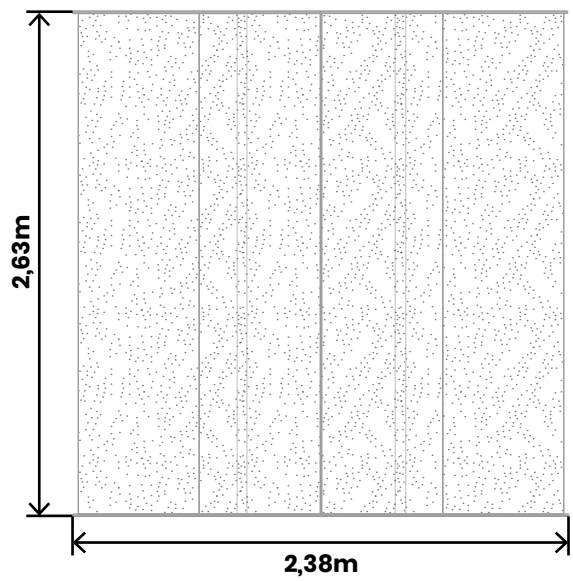

A | x8

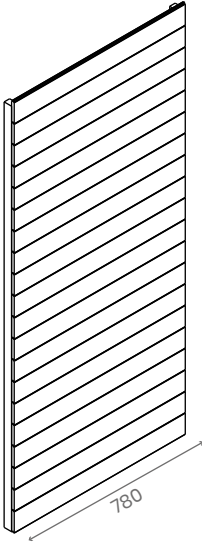

B | x1

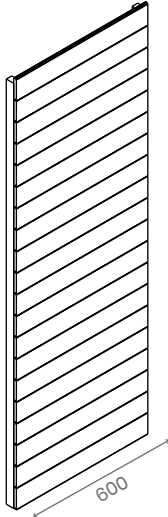

D | x2

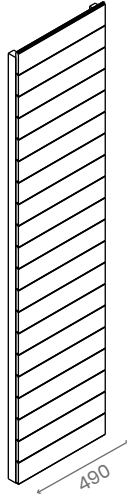

R3 | x2

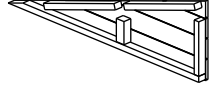

R4 | x2

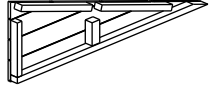

Z4 | x2

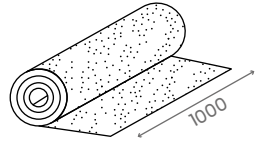

Z5 | x1

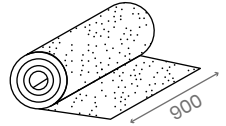

P2 | x1



P3 | x1



8 | x2



9 | x1



10 | x4

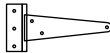

12 | x3

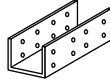

O3 | x6

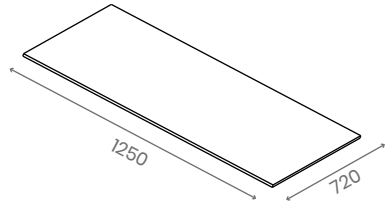

O5 | x2

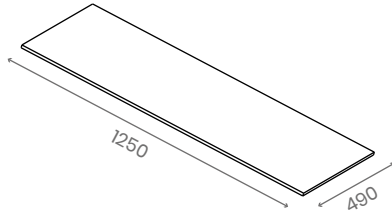

O6 | x8

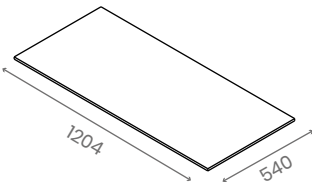

A1 | x8

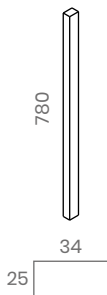

A2 | x8

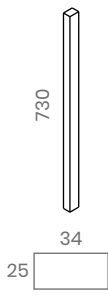

L3 | x1

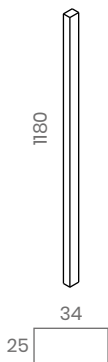

L4 | x1

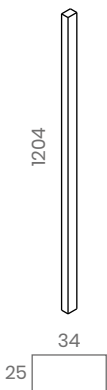

L7 | x6

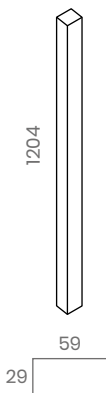

M6 | x4

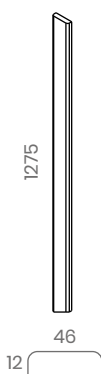

5 | x2

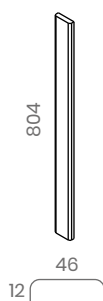

4 | x4

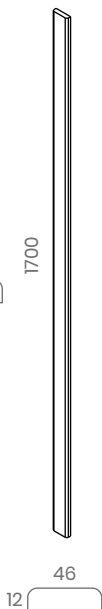

B1 | x1

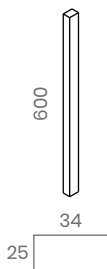

B2 | x1

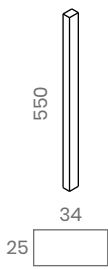

D1 | x2

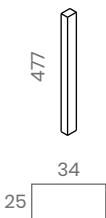

D2 | x2

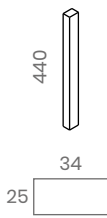

L5 | x15

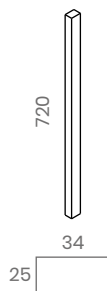

T2 | x46

Ø4 x 60



T5 | x8 Ø3 x 12



T0 | x70 Ø3,5 x 35



T1 | x110 Ø4 x 40



T7 | x24 Ø3,5 x 20



T3 | x8 Ø3 x 20



T4 | x36 Ø3 x 25



T6 | x60 Ø3,5 x 25



T8 | x100



1.1

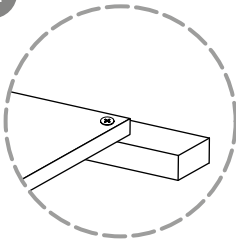

O6 | x8

L5 | x15

T4 | x48

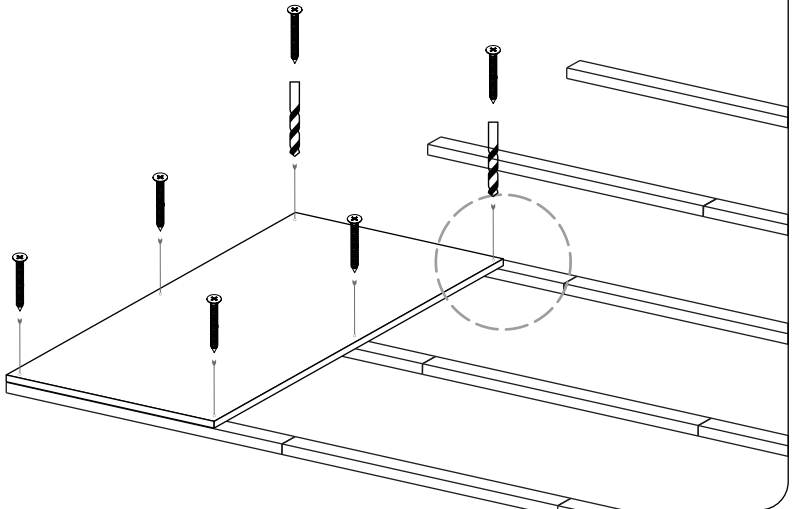
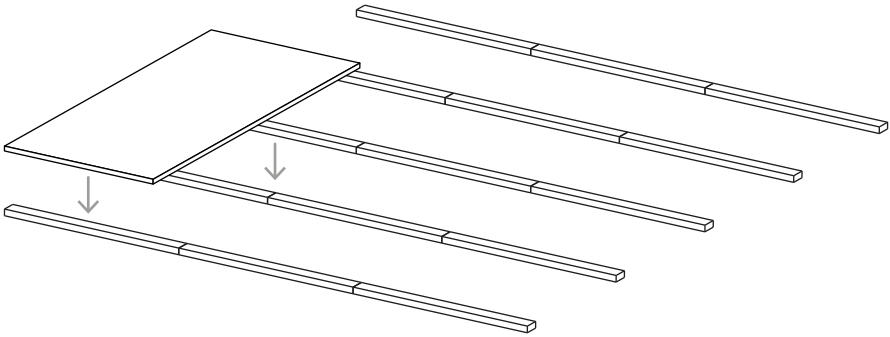
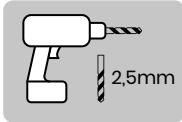

1.2

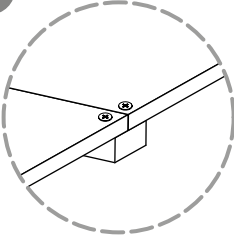

O6 | x8

L5 | x15

T4 | x48 

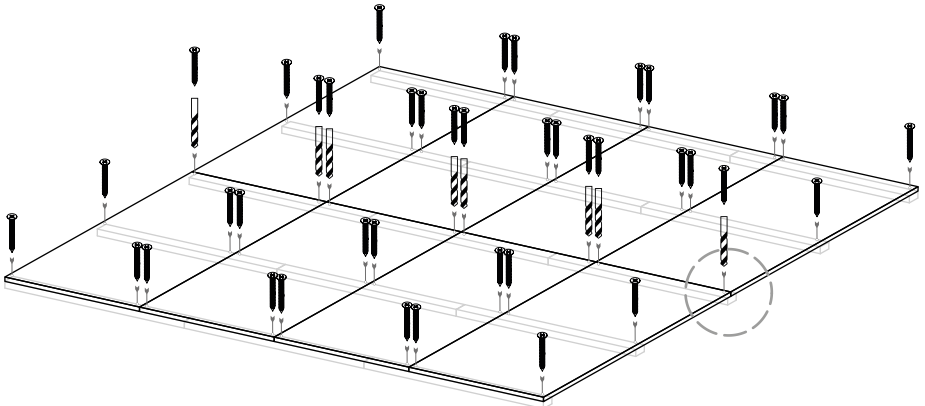
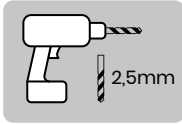
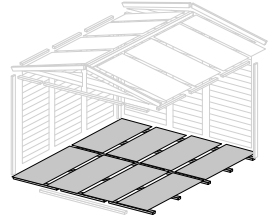

2.1

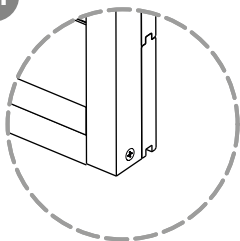

A | x8

A2 | x8

T1 | x16 

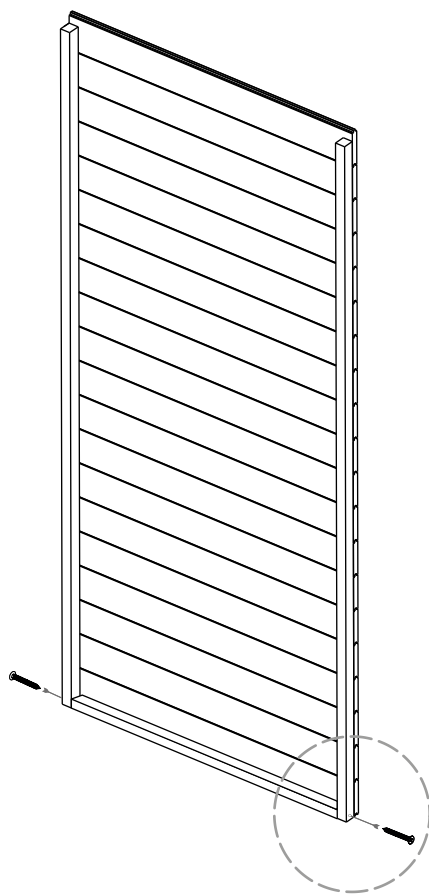
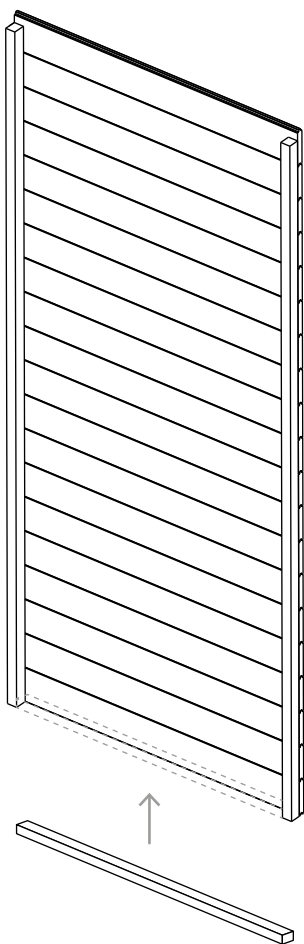
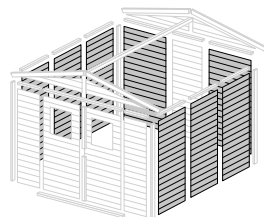

2.2

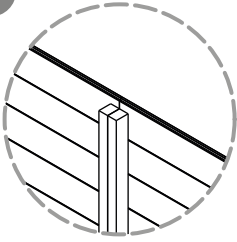

A | x6

T1 | x16 

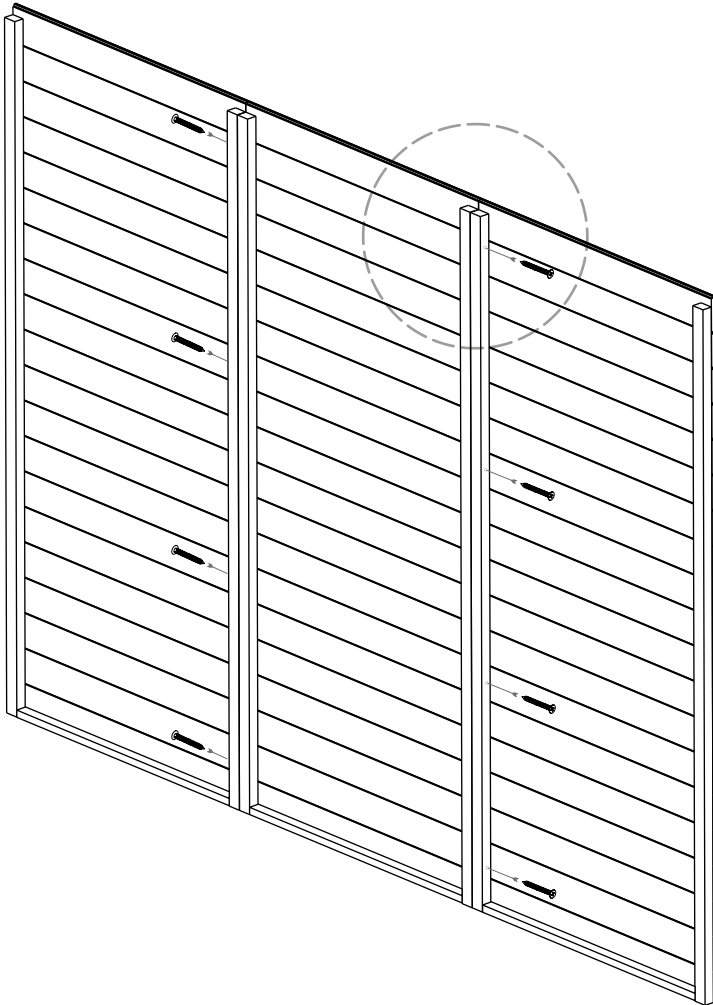
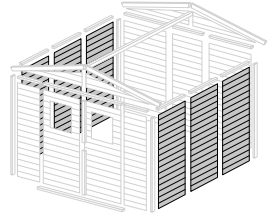

2.3

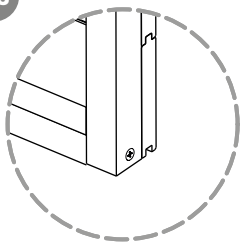

B | x1

B2 | x1

T1 | x2

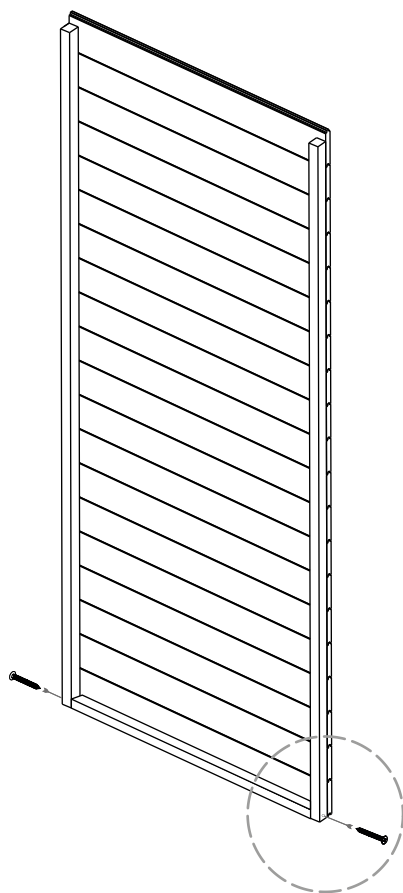
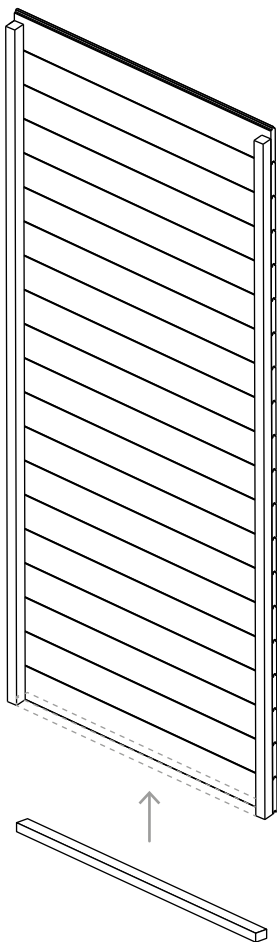
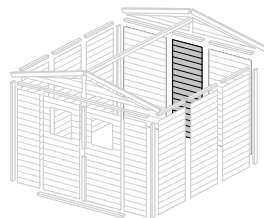

2.4

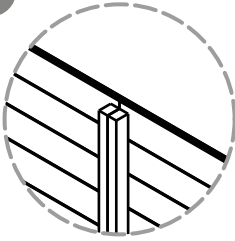

A | x2

B | x1

T1 | x8

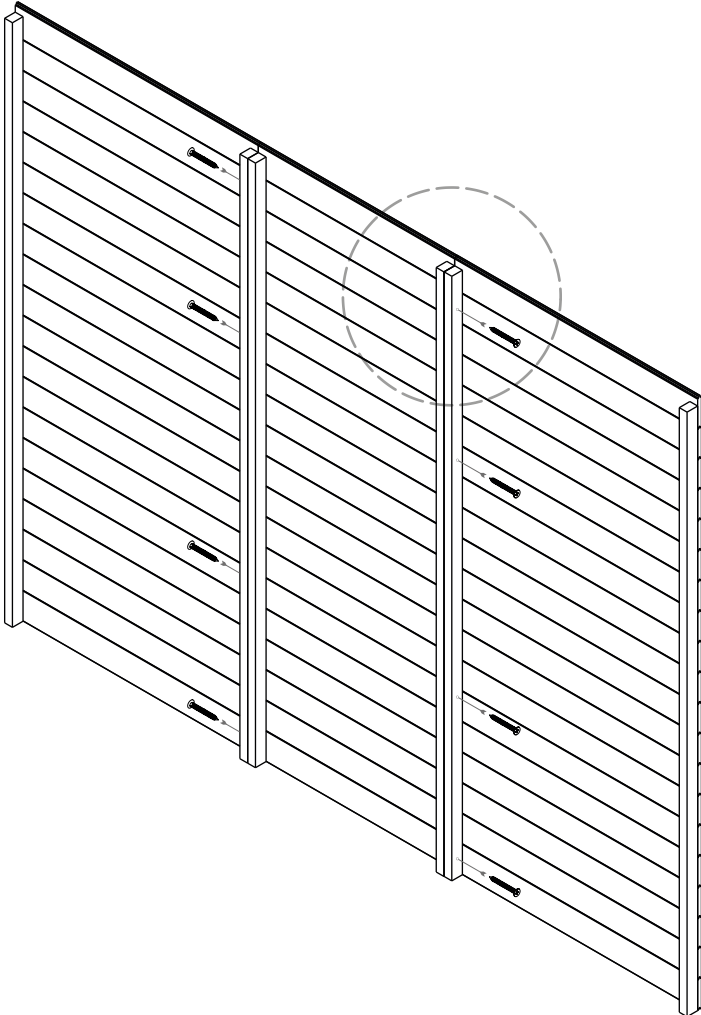
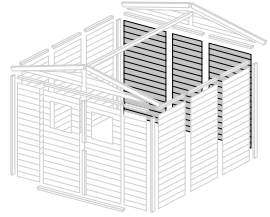

2.5

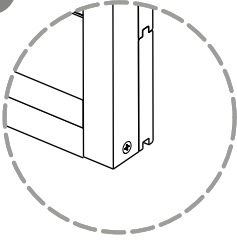

D | x2

D2 | x2

T1 | x4

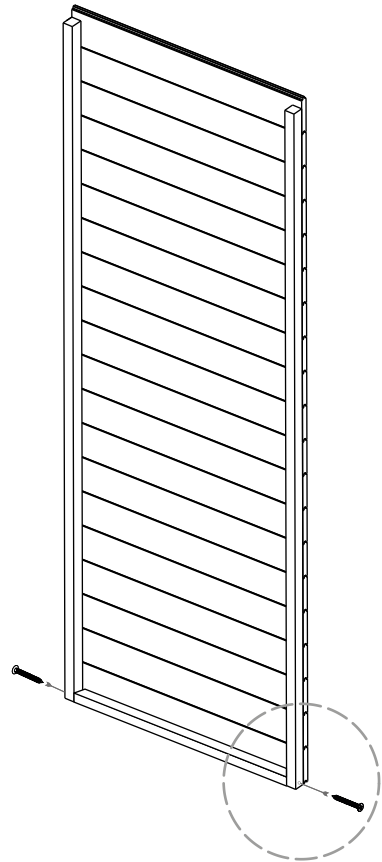
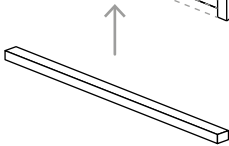
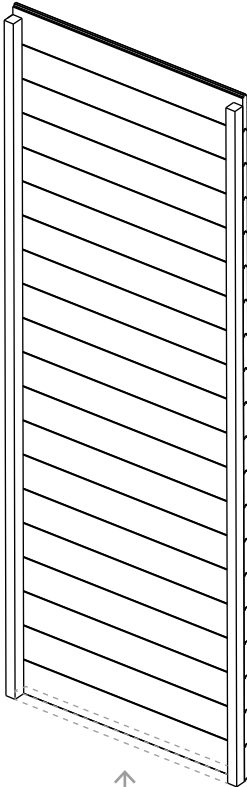
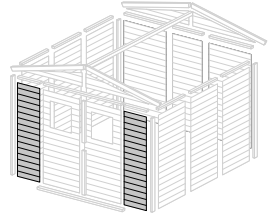

3.1

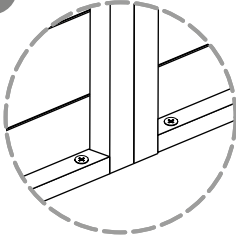

A|x3

T1|x4 

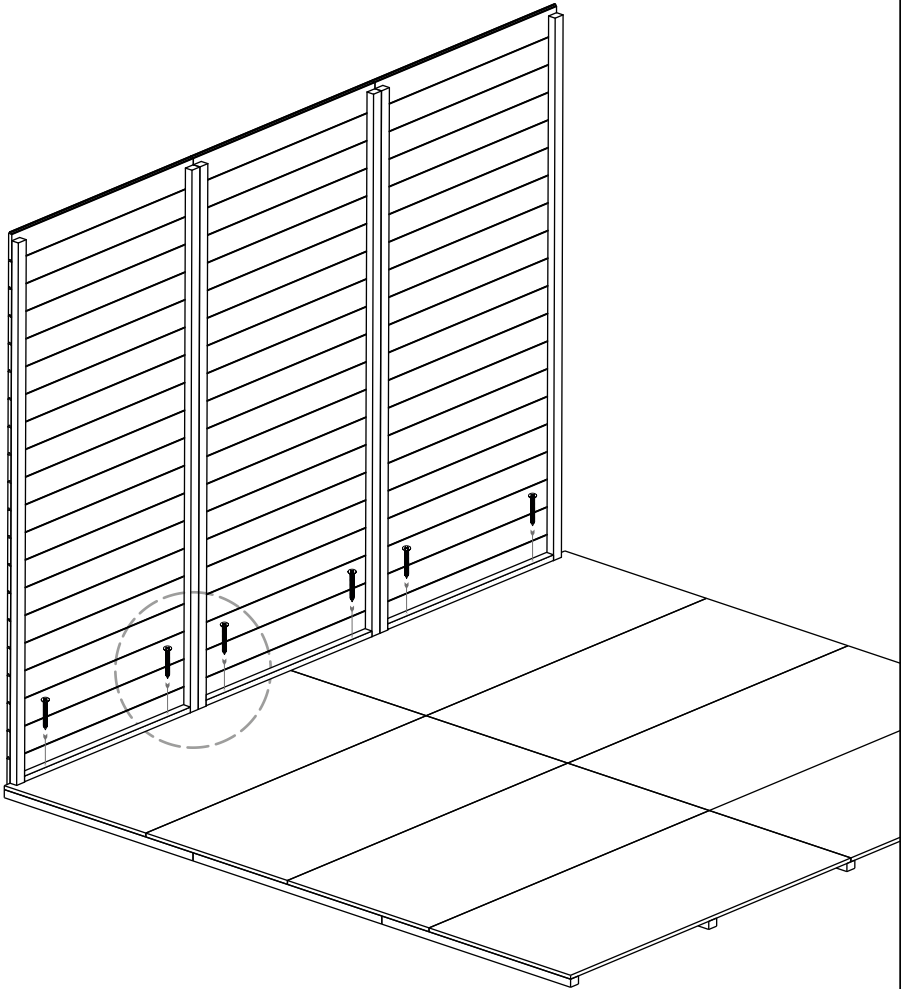
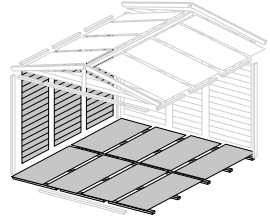

3.2

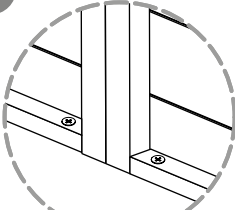

A | x2

B | x1

T1 | x6



T2 | x4

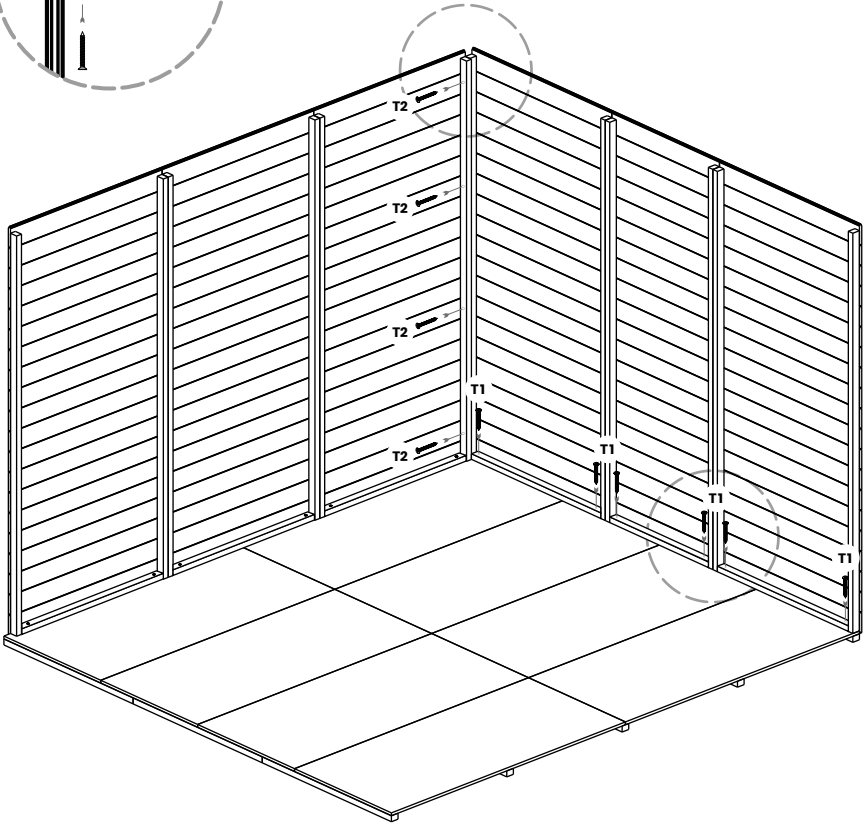
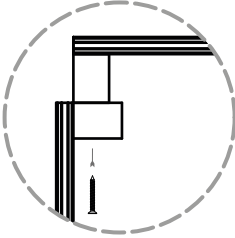
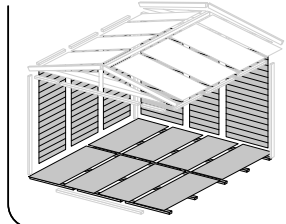

3.3

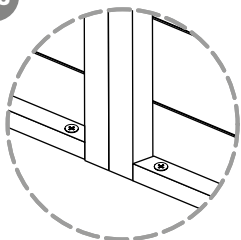

A | x2

B | x1

T1 | x6



T2 | x4

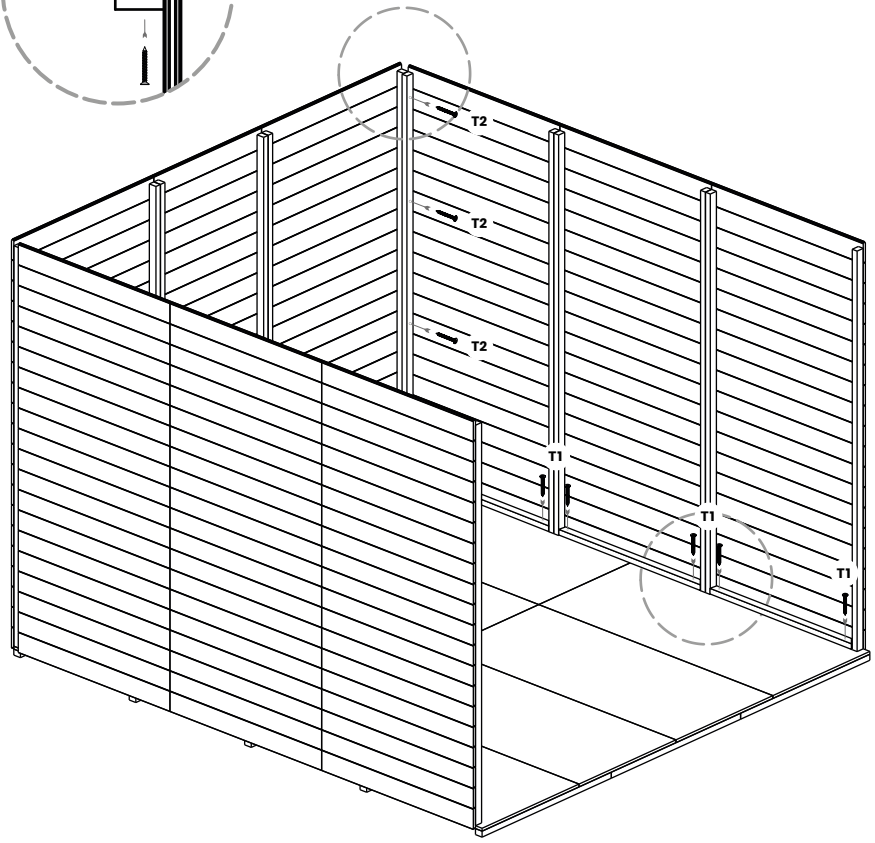
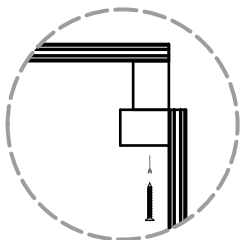
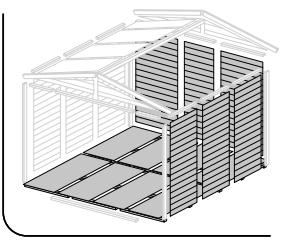

3.4

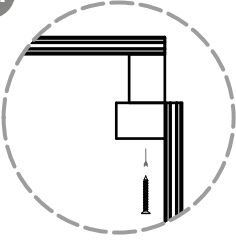

A | x1

D | x1

T1 | x2



T2 | x4

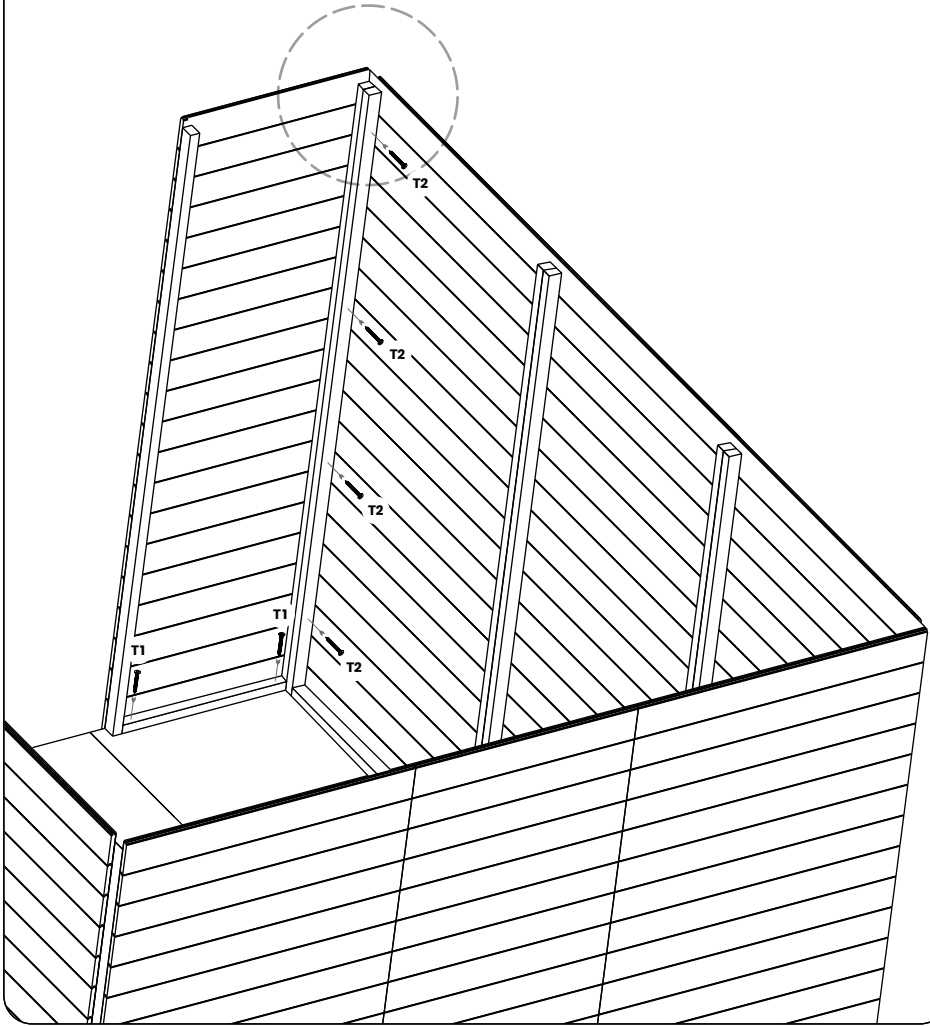
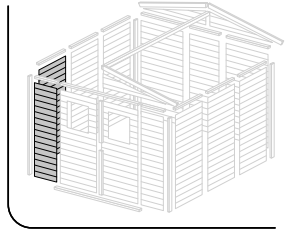

3.5

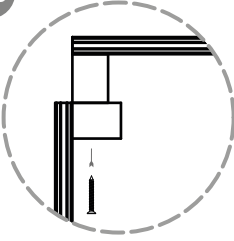

A | x1

D | x1

T1 | x2



T2 | x4

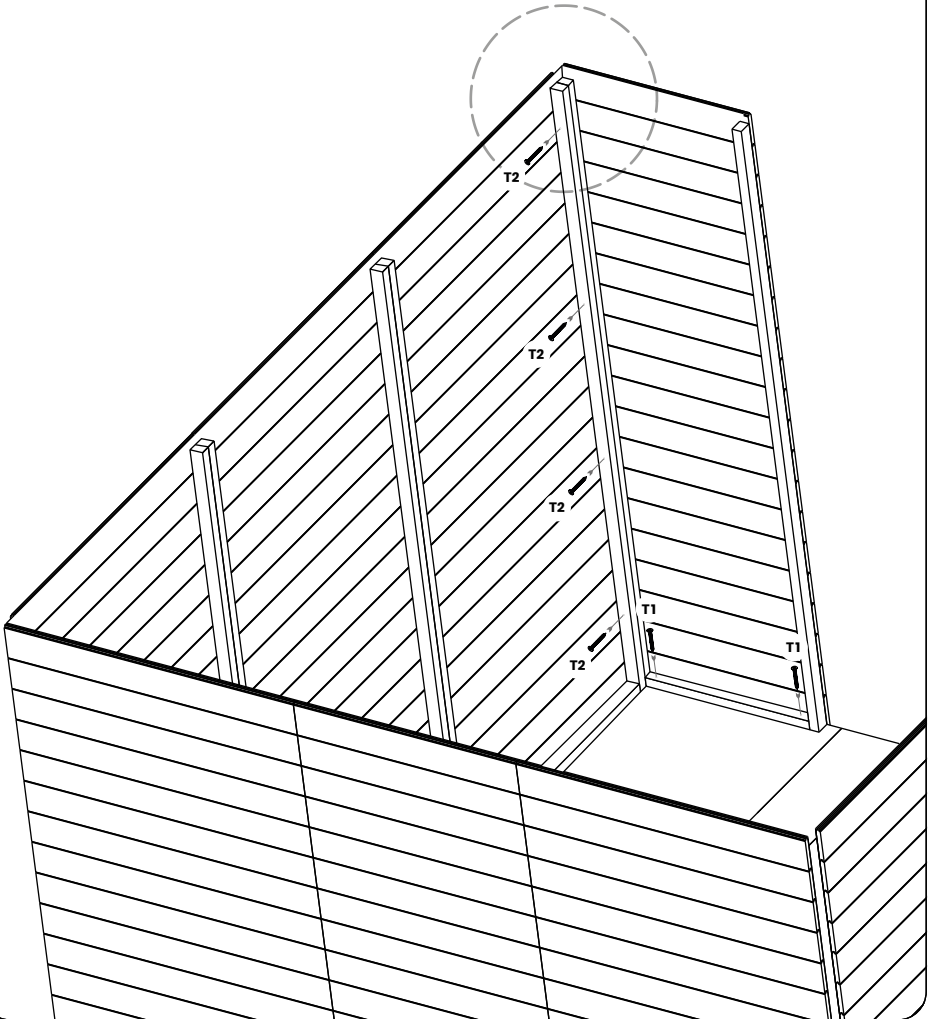
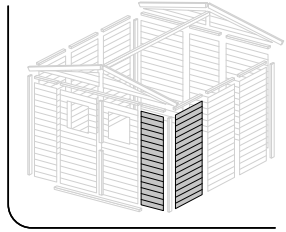

4

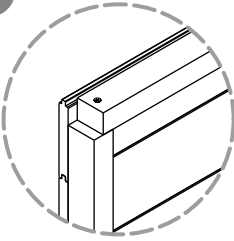

A1 | x8

B1 | x1

D1 | x2

T1 | x22

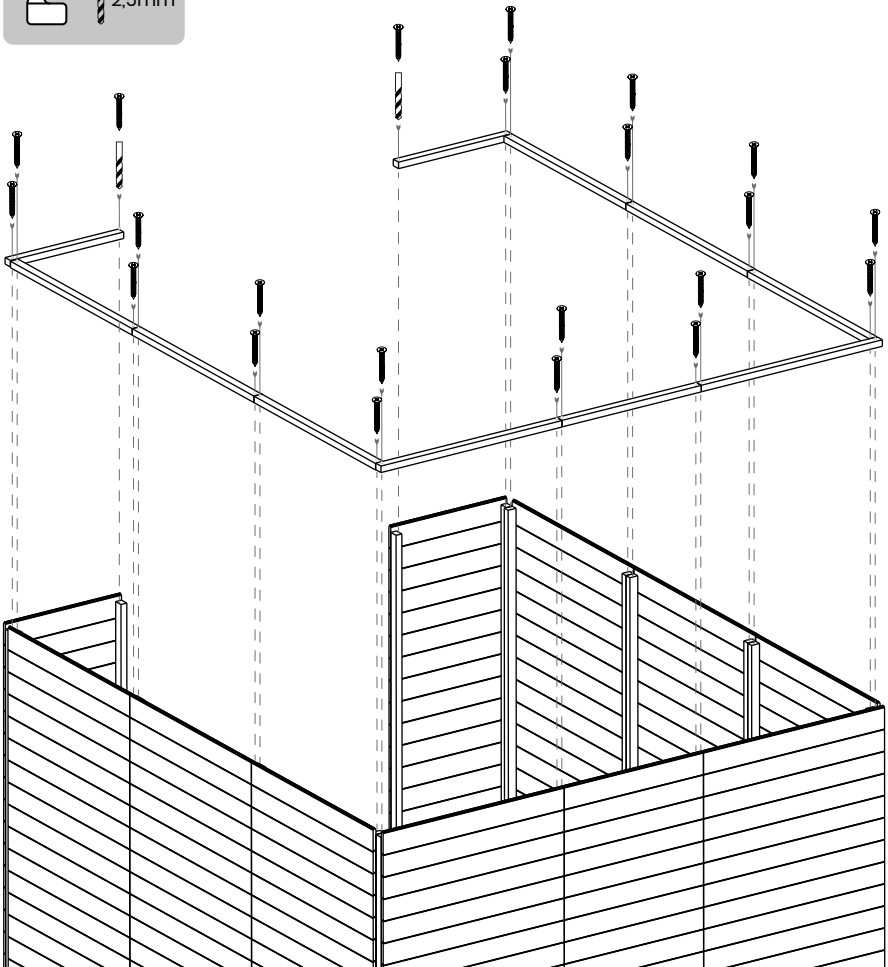
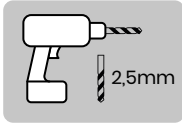
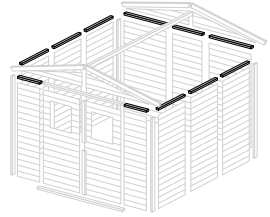

5.1

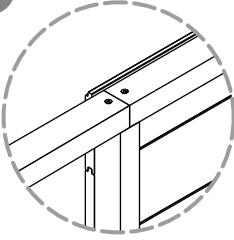

L4 | x1

T1 | x2 

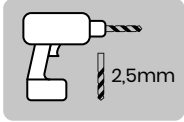
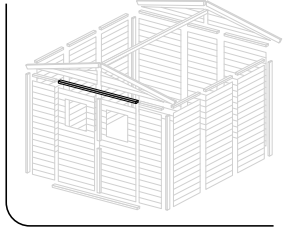

2.5mm

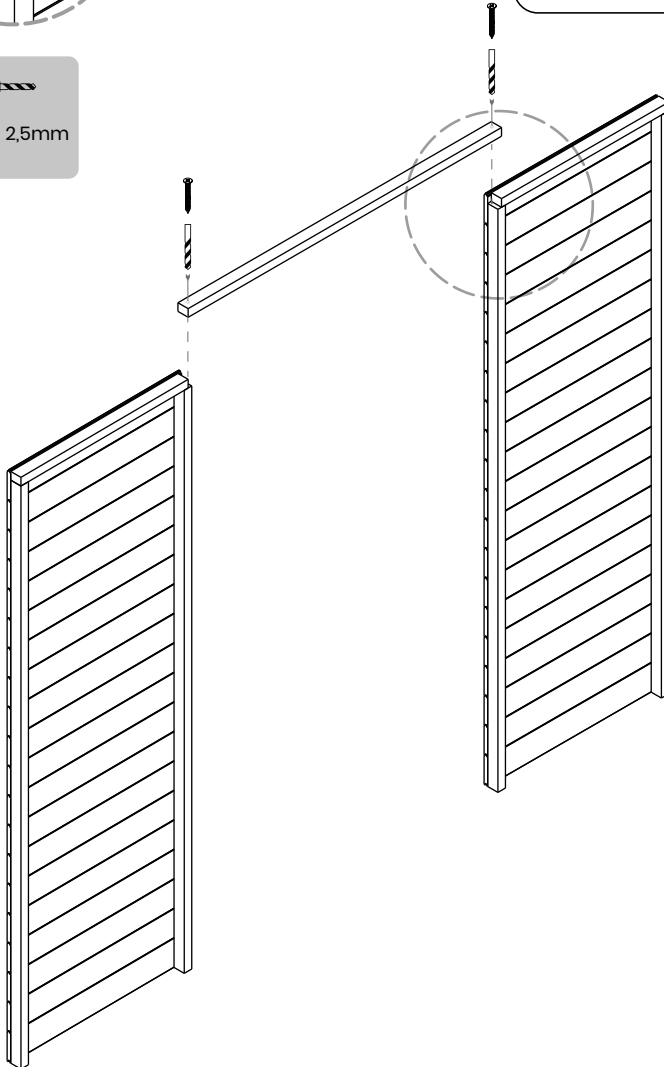

5.2

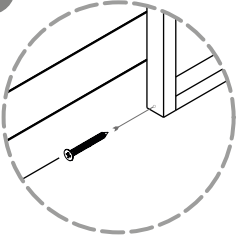

L3 | x1

T1 | x2

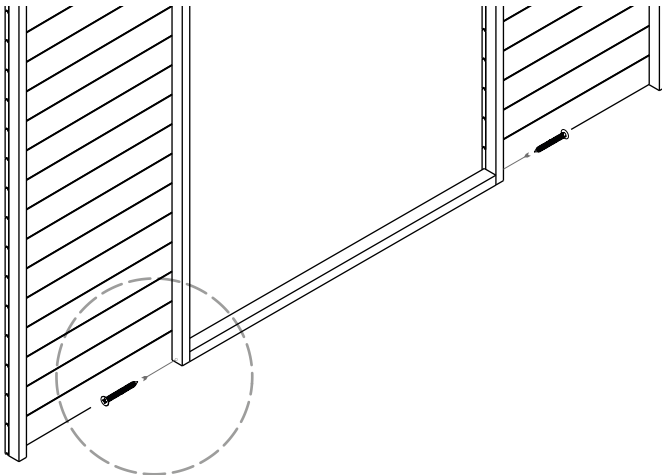
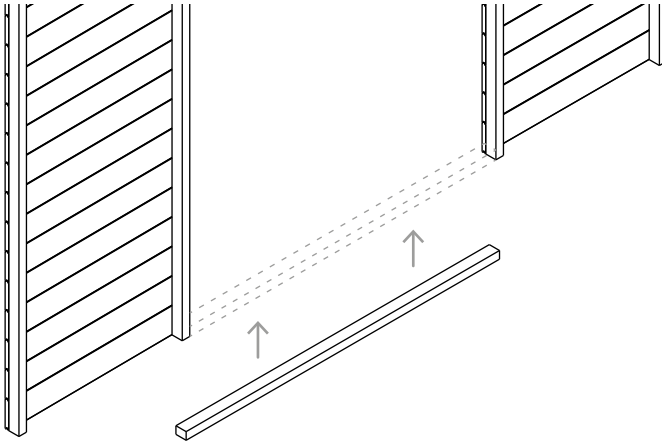
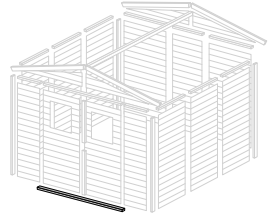

6.1

R3 | x2

R4 | x2

T1 | x16

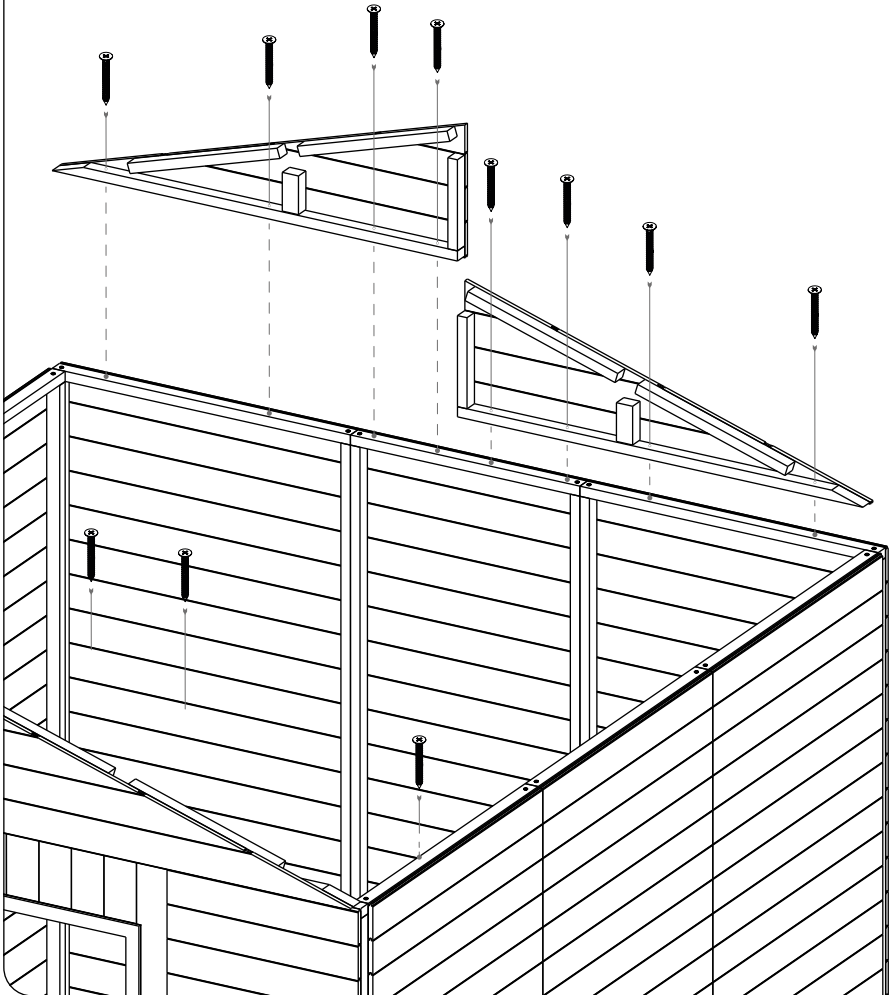

6.2

R3 | x2

R4 | x2

T1 | x4 

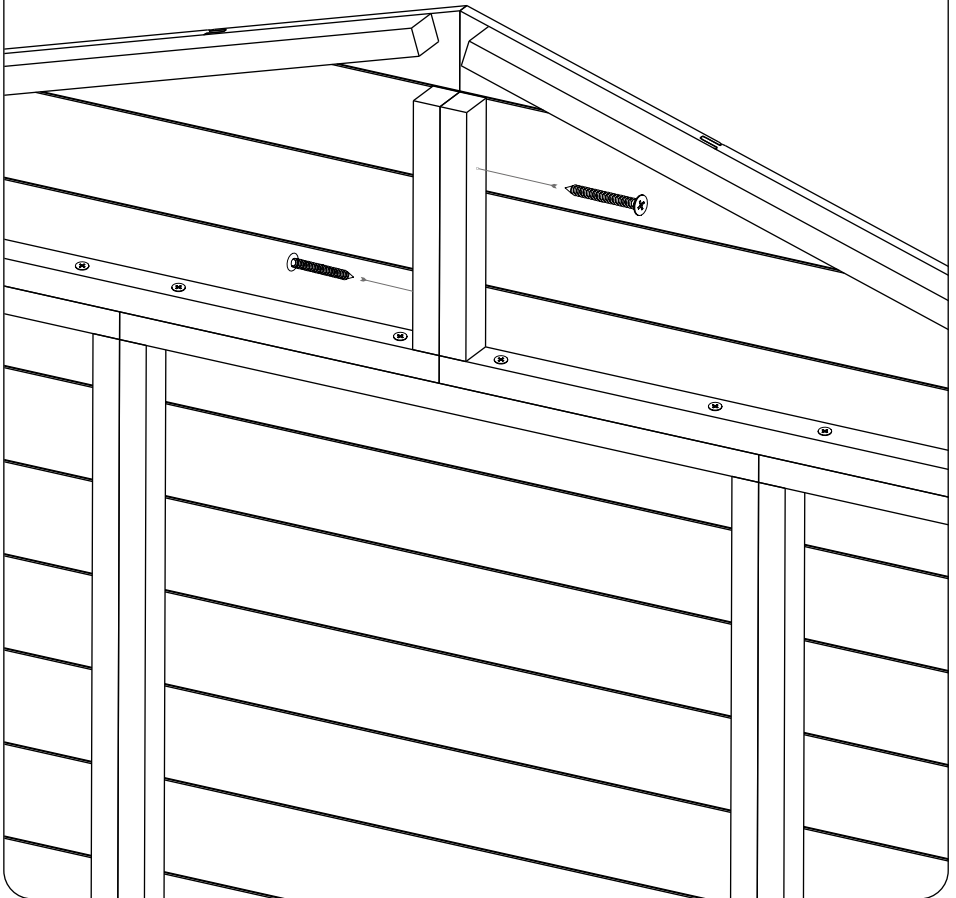

7.1

L7 | x6

12 | x3

T6 | x48 

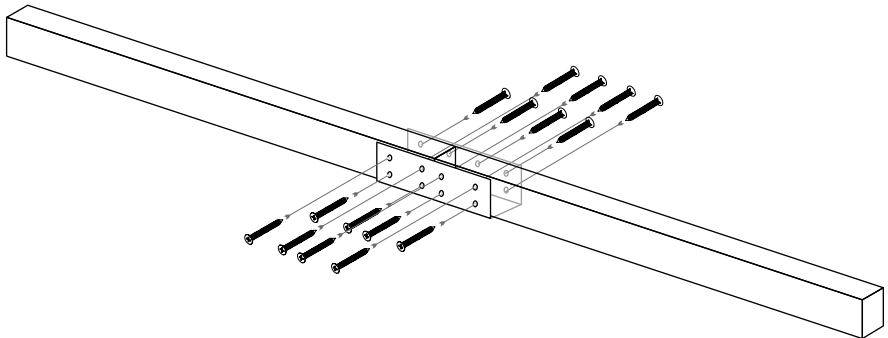
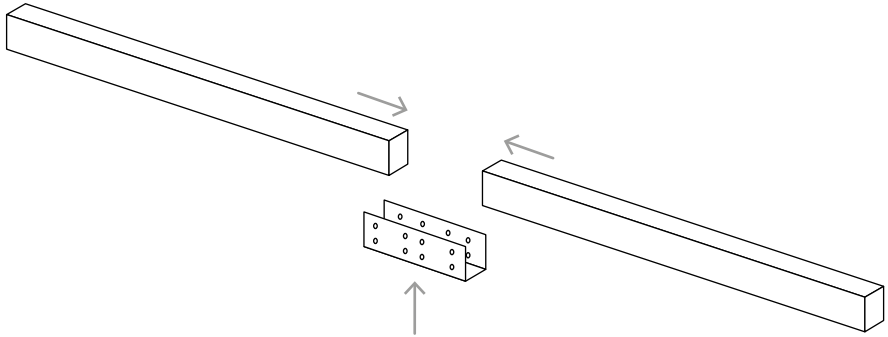
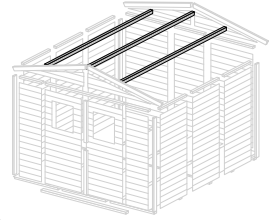

7.2

L7 | x6

12 | x3

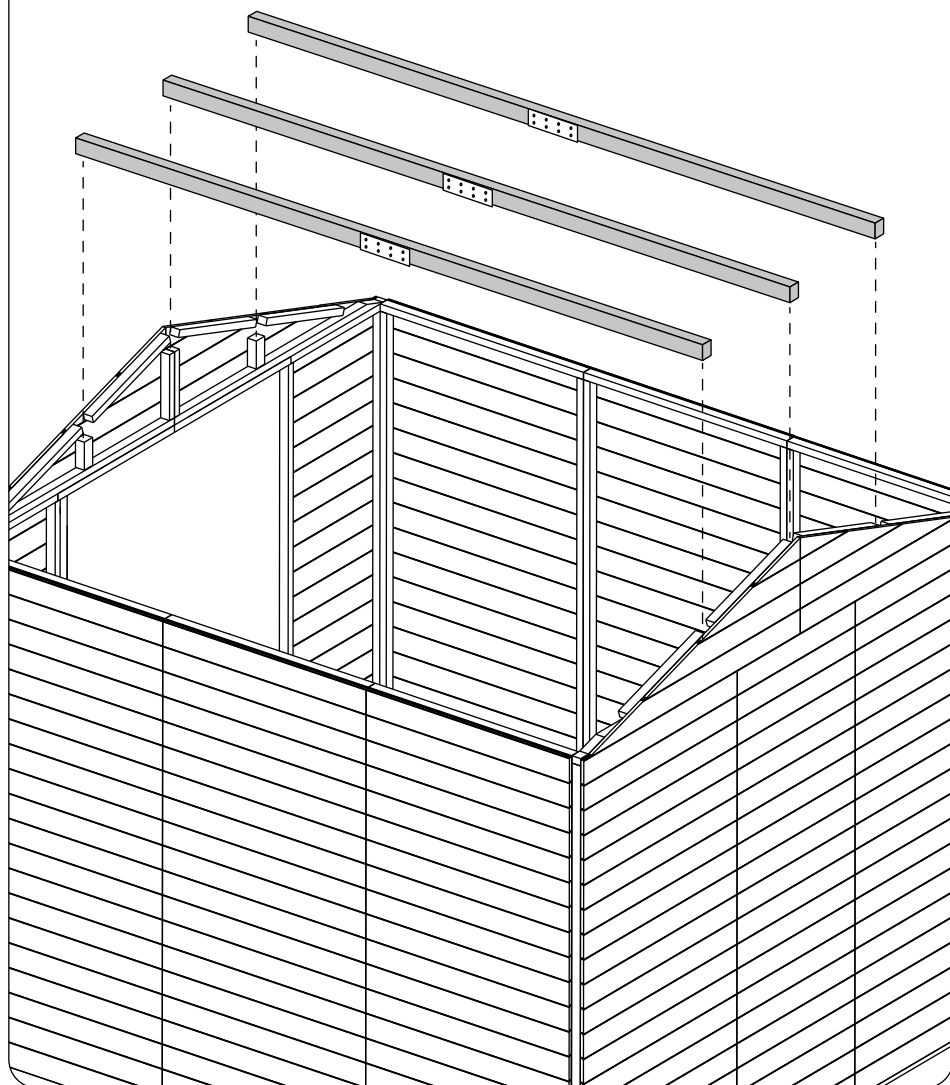
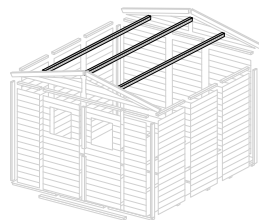

7.3

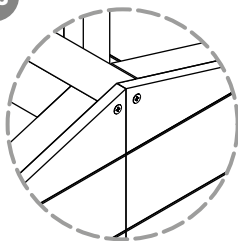

L7|x6

T1|x12

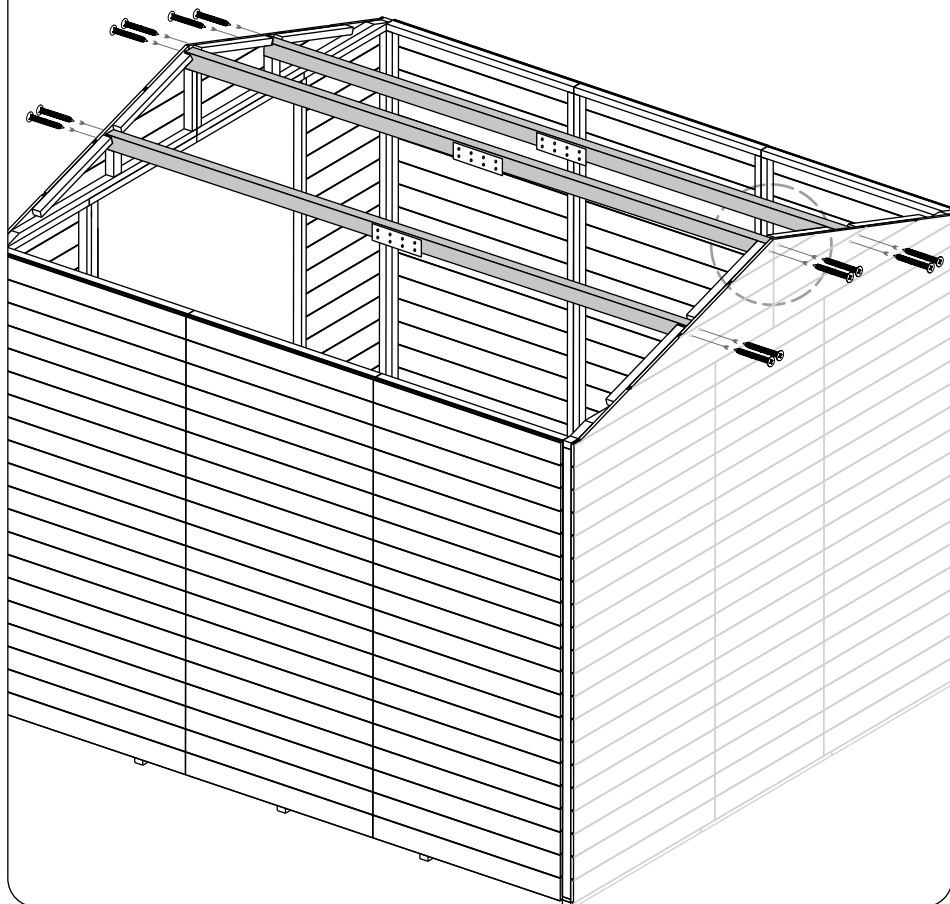
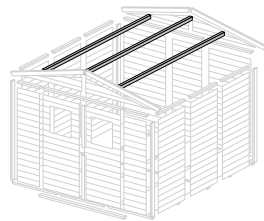

8.1

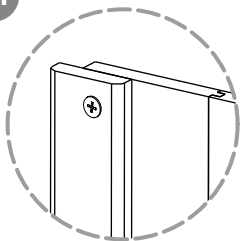

P2 | x1

5 | x2

T3 | x8 

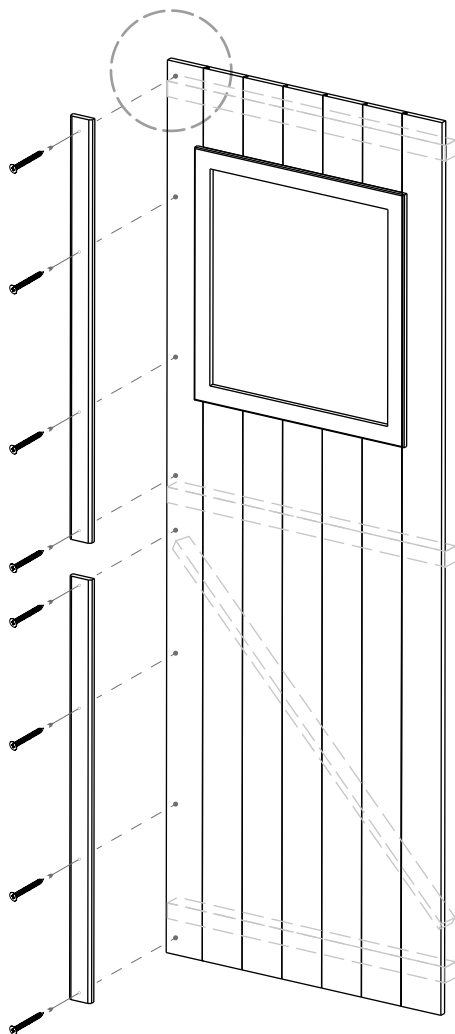
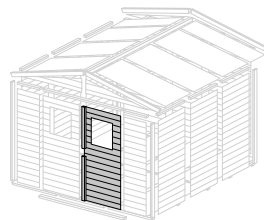

8.2

P2 | x1

P3 | x1

10 | x4

T7 | x12 

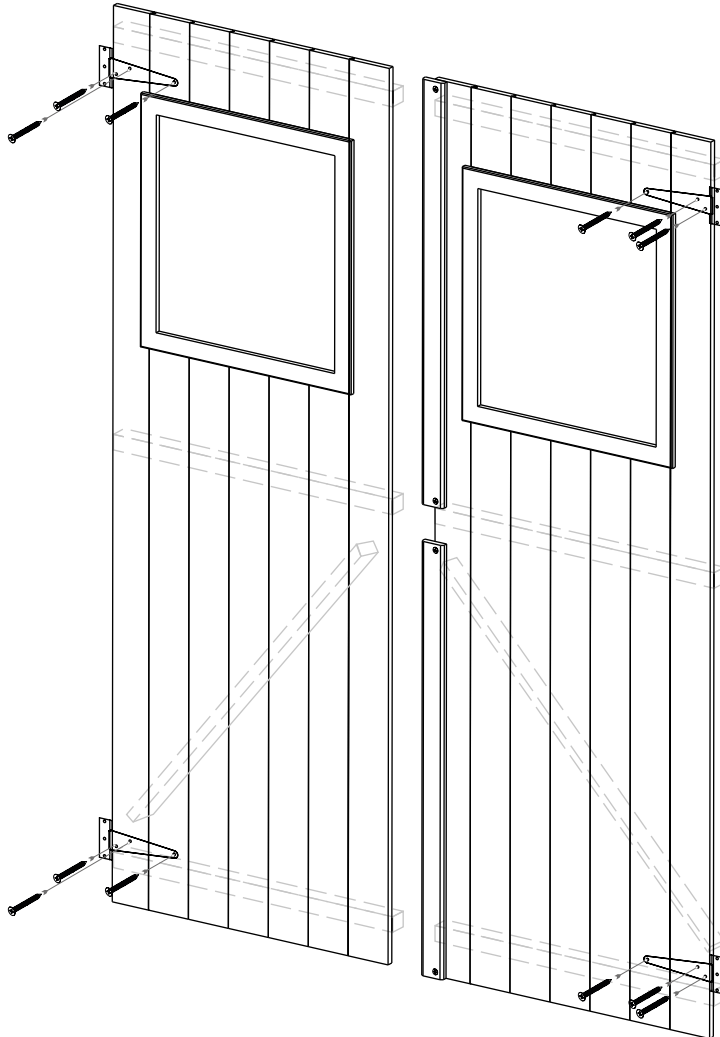

8.3

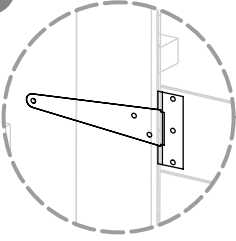

10 | x4

T7 | x12

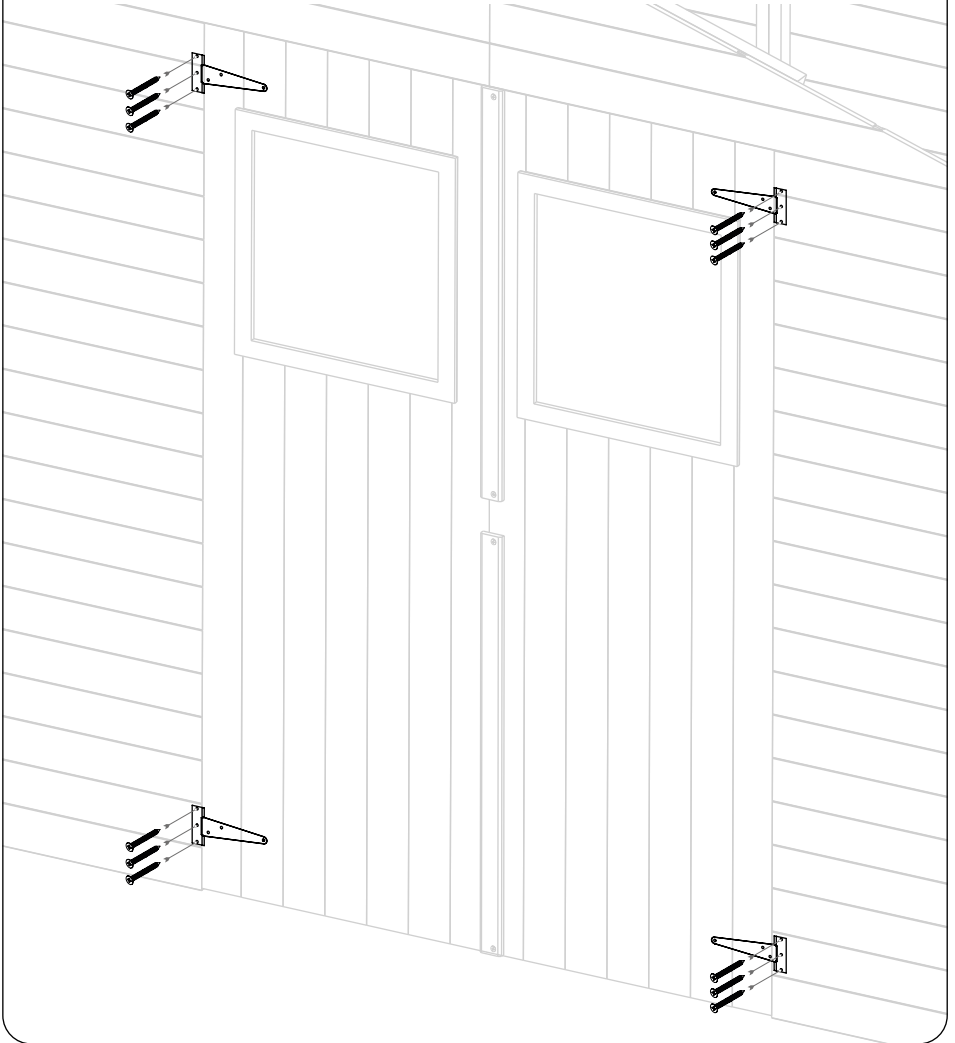
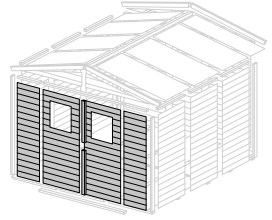

8.4

9 | x1

T5 | x8

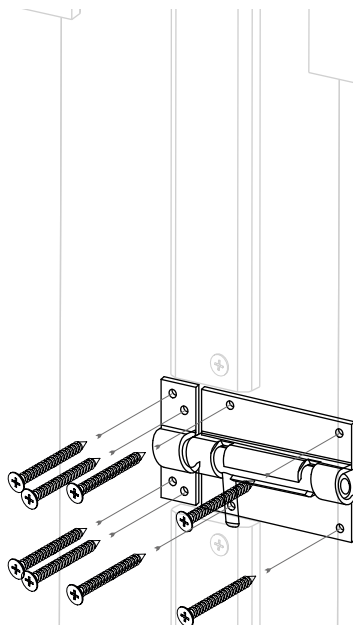
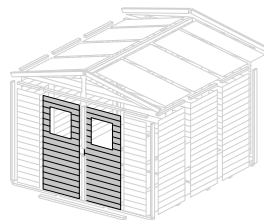

8.5

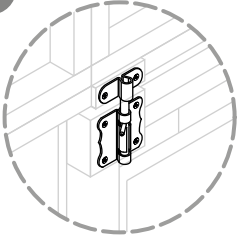

8 | x2

T6 | x12 

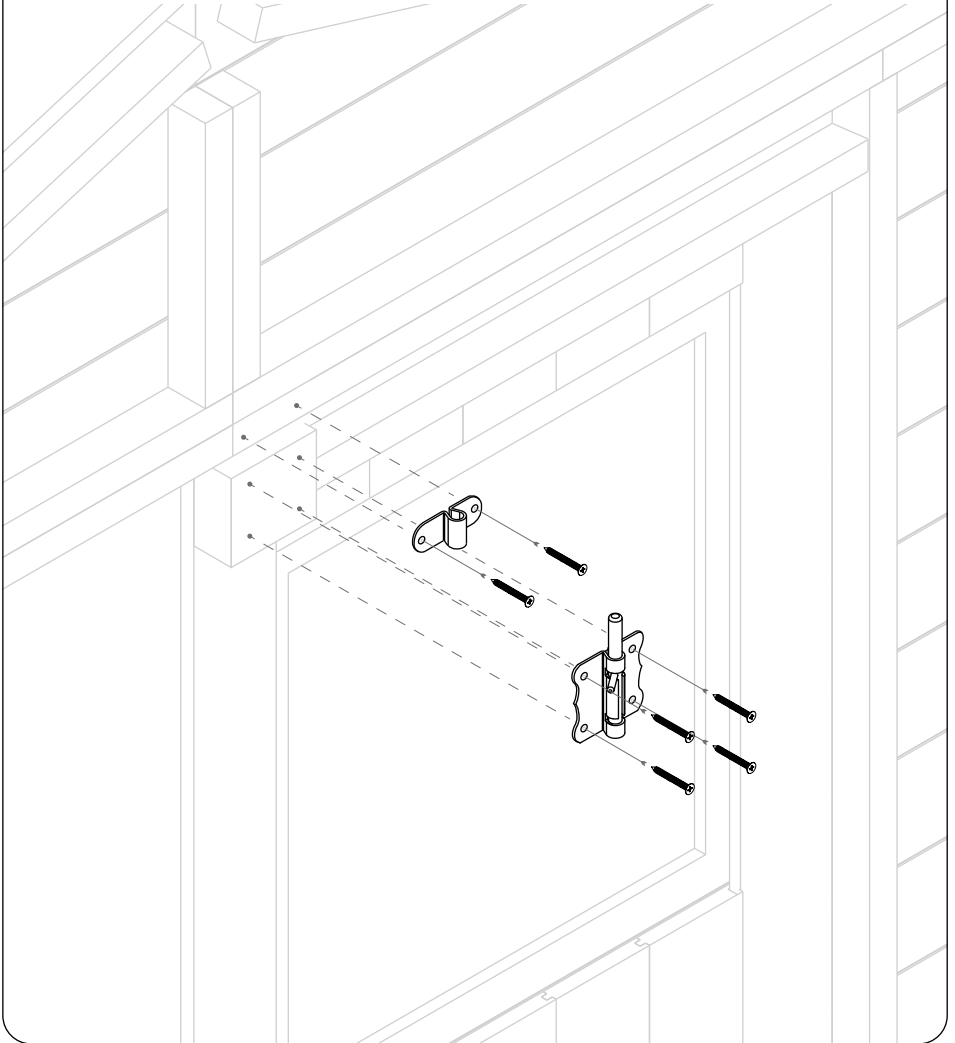
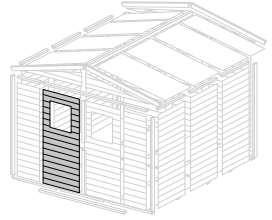

9

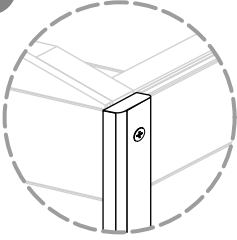

4 | x4

T4 | x16 

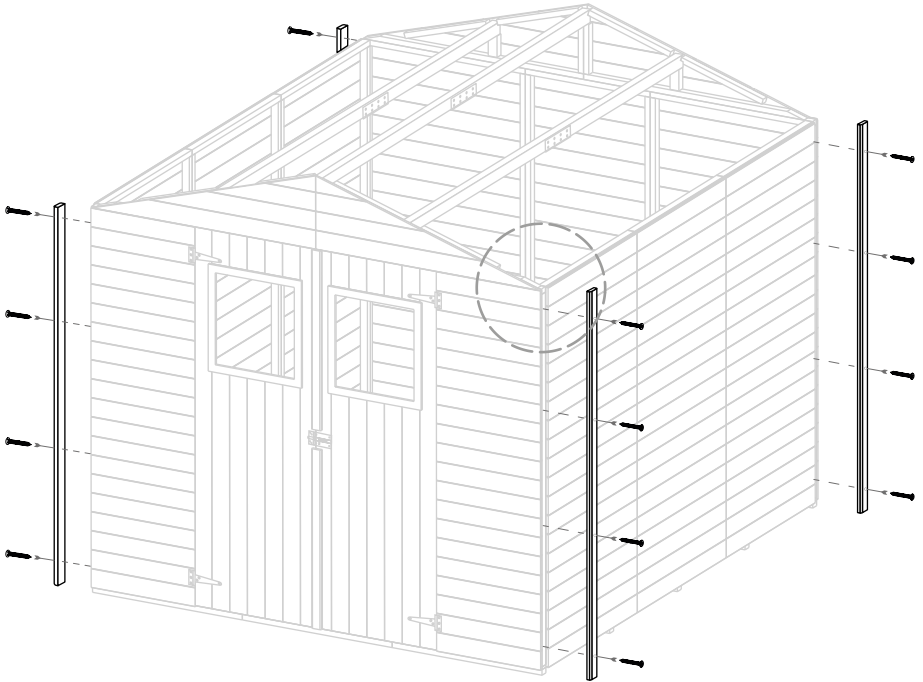
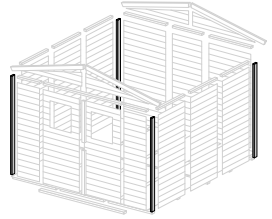

O3 | x6

O5 | x2

T2 | x36 

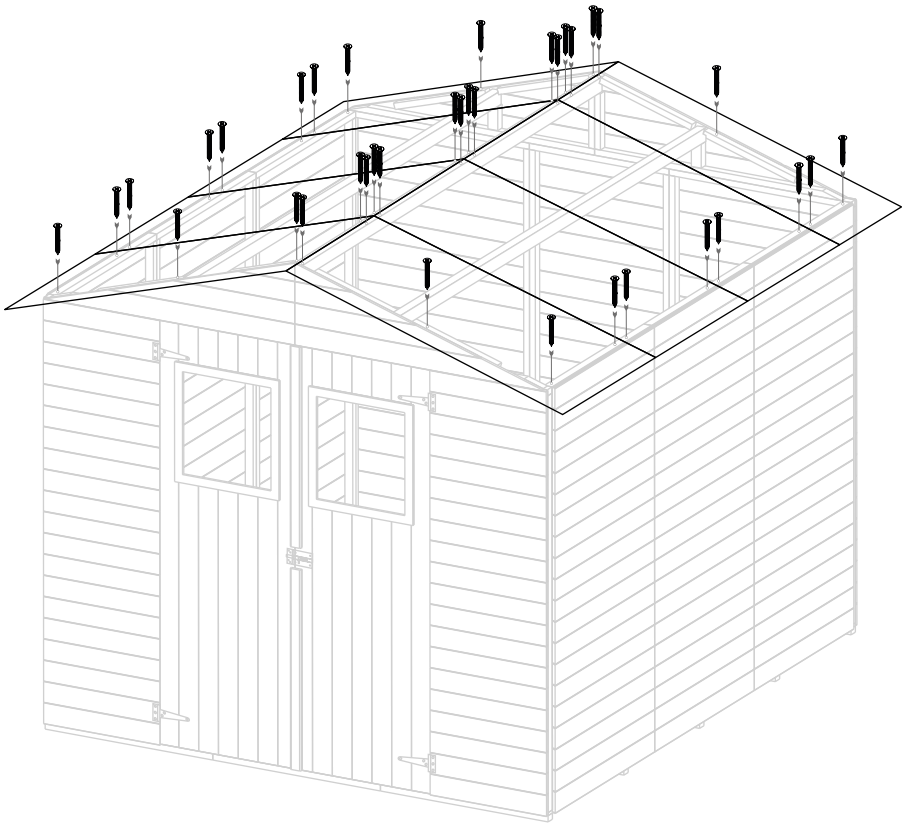

11.1

Z4 | x2

Z5 | x1

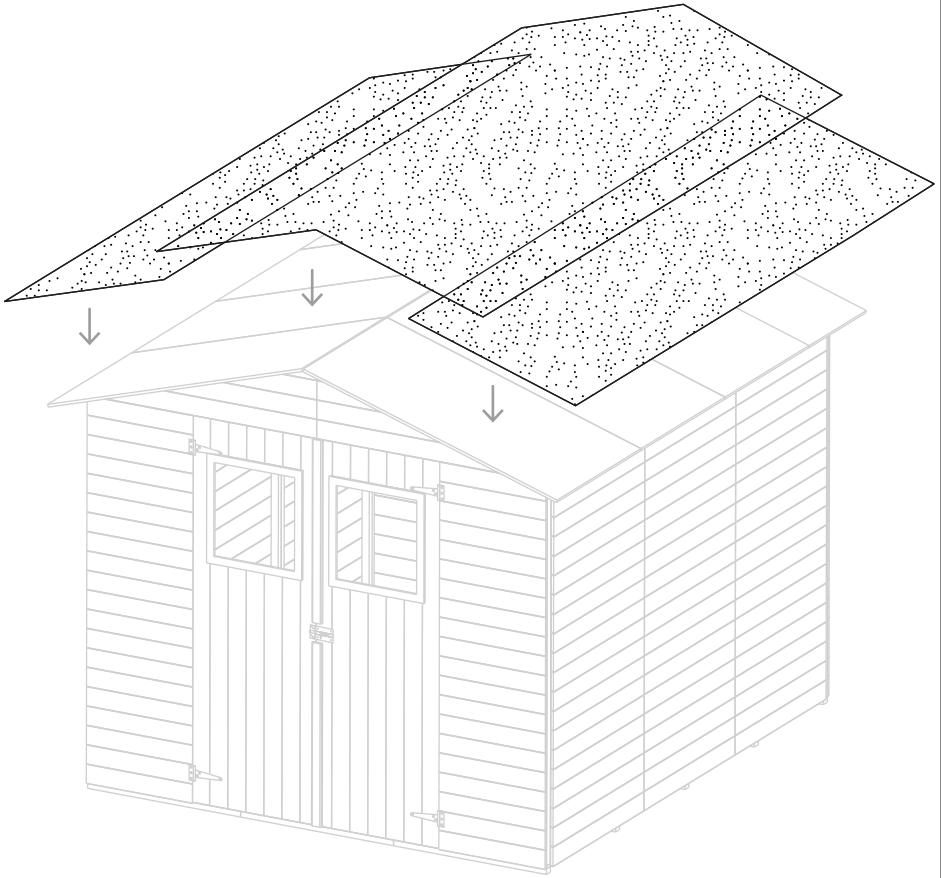
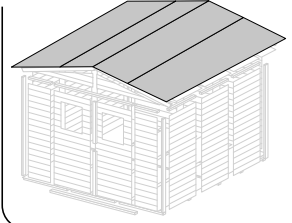

11.2

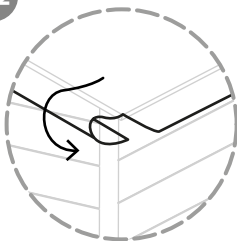

Z4 | x2

T8 | x100 

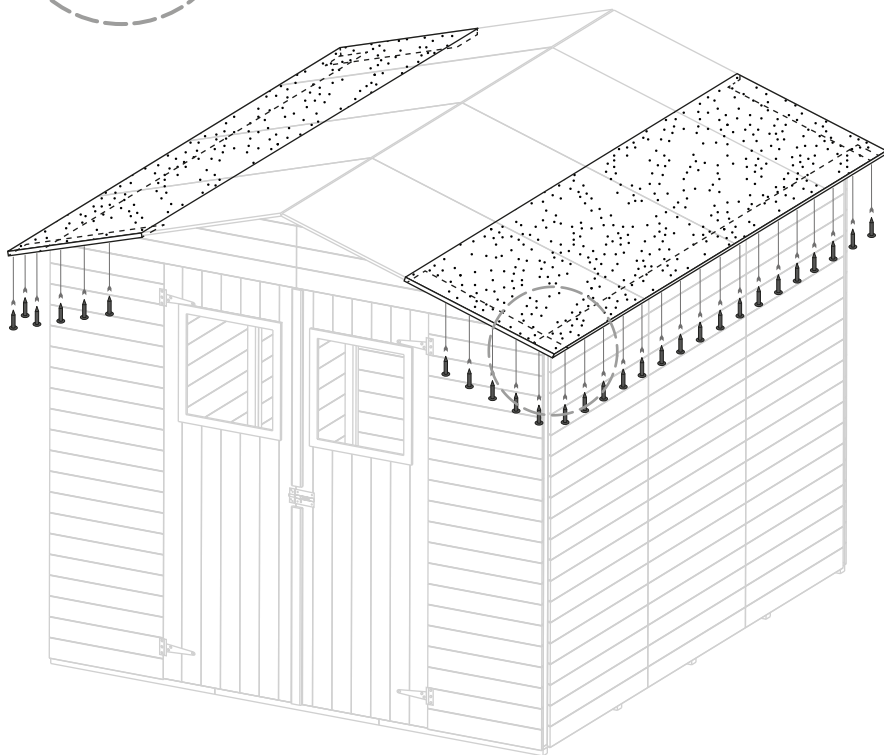
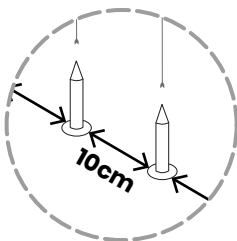
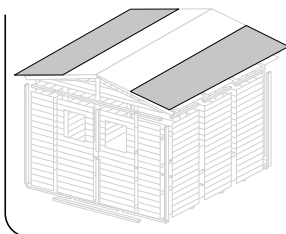

11.3

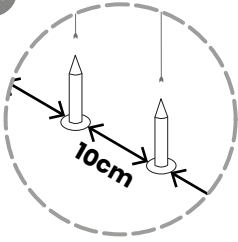

Z5 | x1

T8 | x100 

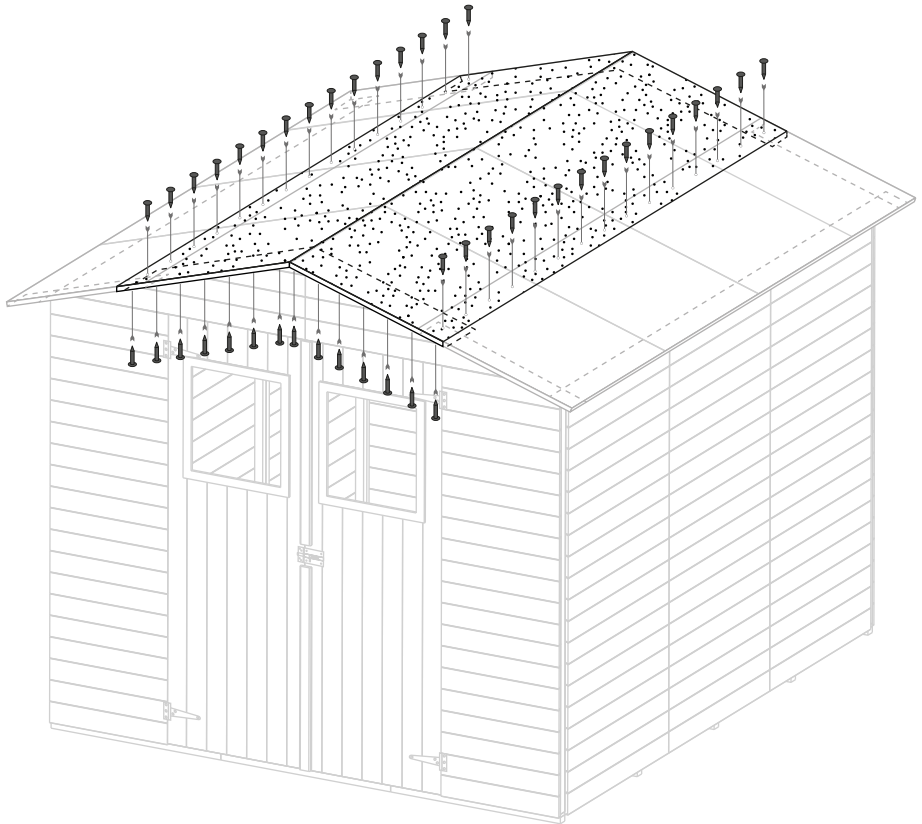
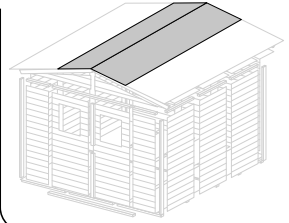

M6 | x4

T4 | x16 

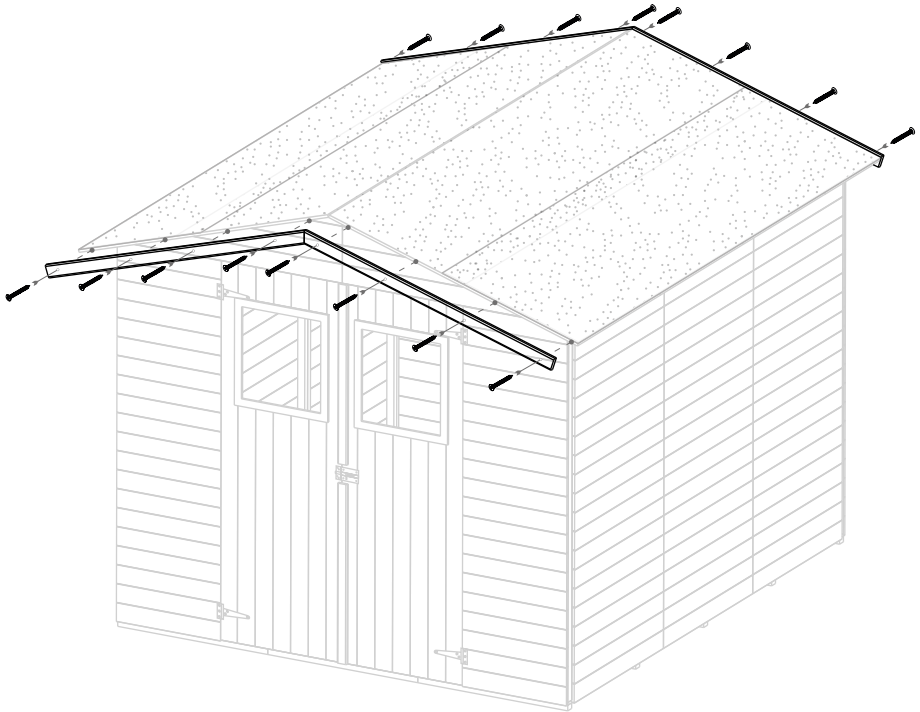
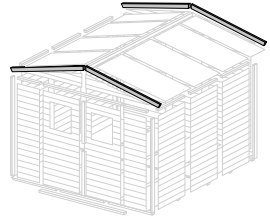

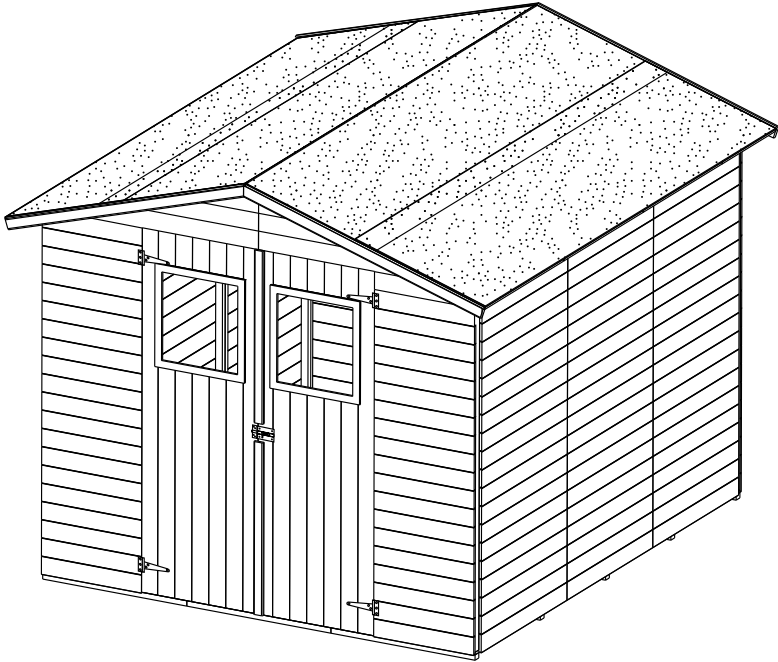

Thank
you and
congratulations!



OKORU GLOBAL S.L. // Pol. Ind. Barros nº 29. 39408 Barros. Cantabria - España
(+34) 942 842 170 · info@okorules // MADE IN P.R.C.